

TECHNICAL MANUAL

**GS AND DEPOT MAINTENANCE MANUAL
INCLUDING REPAIR PARTS AND SPECIAL TOOLS LIST**

TELEPHONE

TEST SET

TS-716/U

HEADQUARTERS, DEPARTMENT OF THE ARMY

SEPTEMBER 1971

WARNING
DANGEROUS VOLTAGES EXISTS
IN THIS EQUIPMENT

Be careful when working on the 115/230-volt ac line connections. Be careful when working on the TEL LINE panel terminals. 100 volts dc may be on these terminals. Serious injury or death may result from contact with these points.

DON'T TAKE CHANCES!

**GS and Depot Maintenance Manual
 Including Repair Parts and Special Tools List
 TELEPHONE TEST SET TS-716/U**

	Paragraph	Page
CHAPTER 1. INTRODUCTION		
Scope-----	1-1	1-1
Indexes of publications-----	1-2	1-1
2. FUNCTIONING OF EQUIPMENT		
General-----	2-1	2-1
Block diagram-----	2-2	2-1
Noise generator assembly 1A3A3-----	2-3	2-2
Power amplifier assembly 1A3A4-----	2-4	2-2
Preamplifier assembly 1A3A1-----	2-5	2-3
Meter amplifier assembly 1A3A2-----	2-6	2-3
Ring generator assembly 1A3A8-----	2-7	2-3
Transmission efficiency assembly 1A3A-----	2-8	2-4
Dial percent break assembly 1A3A9-----	2-9	2-4
Dial speed assembly 1A3A10-----	2-10	2-5
Positive power supply assembly 1A3A-----	2-11	2-5
Negative power supply assembly 1A3A6-----	2-12	2-5
3. TROUBLESHOOTING		
General instructions-----	3-1	3-1
Test equipment required-----	3-2	3-1
Troubleshooting chart-----	3-3	3-2
Voltage measurements-----	3-4	3-21
Resistance measurements of plug-in assemblies-----	3-5	3-23
Dc resistance of transformers and coils-----	3-6	3-24
4. REPAIRS AND ALIGNMENT		
General parts replacement techniques-----	4-1	4-1
Test equipment required for alignment-----	4-2	4-1
Acoustic output adjustment 1A3R11-----	4-3	4-1
Meter amplifier gain adjustment 1A3R16-----	4-4	4-1
Microphone equalization adjustment 1A2A14R2-----	4-5	4-2
Dial speed adjustment A3R15-----	4-6	4-2
Noise generator load driver adjustment 1A3R9-----	4-7	4-2
5. SHIPMENT AND LIMITED STORAGE		
Disassembly of equipment-----	5-1	5-1
Repackaging for shipment or limited storage-----	5-2	5-1
6. DEPOT OVERHAUL STANDARDS		
Applicability of depot overhaul standards-----	6-1	6-1
Applicable references-----	6-2	6-1
Test equipment required for depot testing-----	6-3	6-1
General test requirements-----	6-4	6-1
Sound source supply test-----	6-5	6-2
Driver impedance test-----	6-6	6-2
Driver distortion test-----	6-7	6-2
Coupler-microphone distortion test-----	6-8	6-2
Microphone preamplifier frequency response and gain test-----	6-9	6-3
Microphone preamplifier distortion test-----	6-10	6-4
Meter amplifier gain test-----	6-11	6-4
Meter scale test-----	6-12	6-4
Circuit tests requirements-----	6-13	6-4
Insulation resistance test-----	6-14	6-5
Continuity test-----	6-15	6-5
Hand generator test-----	6-16	6-5
Ringer test-----	6-17	6-5

		Paragraph	Page
CHAPTER	6.	Dial speed test -----	6-18
		Dial percent break test -----	6-19
		Driver frequency response test-----	6-20
		Coupler microphone frequency response test-----	6-21
APPENDIX	A.	REFERENCES-----	A-1
	B.	GENERAL SUPPORT AND DEPOT MAINTENANCE REPAIR	
		PARTS AND SPECIAL TOOLS LIST -----	B-1

**CHAPTER 1
INTRODUCTION**

1-1. Scope

a. This manual contains general support (GS) and depot maintenance instructions for Telephone Test Set TS-716/U (test set) (FIG. 1-1). It includes instructions appropriate to GS and depot for troubleshooting, testing, aligning, and repairing the equipment. It also lists tools, materials, and test equipment required and contains a repair parts list (app B).

b. The complete technical manual for this equipment includes TM 11-6625-596-12 and TB 11-6625-596-12/1.

c. Appendix B is current as of 21 June 1971.

d. The reporting of errors, omissions, and recommendations for improving this publication by the individual user is encouraged. Reports should be submitted on DA Form 2028 (Recommended Changes to Publications) and forwarded direct to: Commanding

General, U. S. Army Electronics Command ATTN: AMSEL-ME-NMP- EM, Fort Monmouth, N.J. 07703.

NOTE

For applicable forms and records, see TM 11-6625-596-12.

1-2. Indexes of Publications

a. *DA Pam 310-4.* Refer to the latest issue of DA Pam 310-4 to determine whether there are new editions, changes, or additional publications pertaining to the equipment.

b. *DA Pam 310-7.* Refer to the latest issue of DA Pam 310-7 to determine whether there are modification work orders (MWO's) applicable to the equipment.

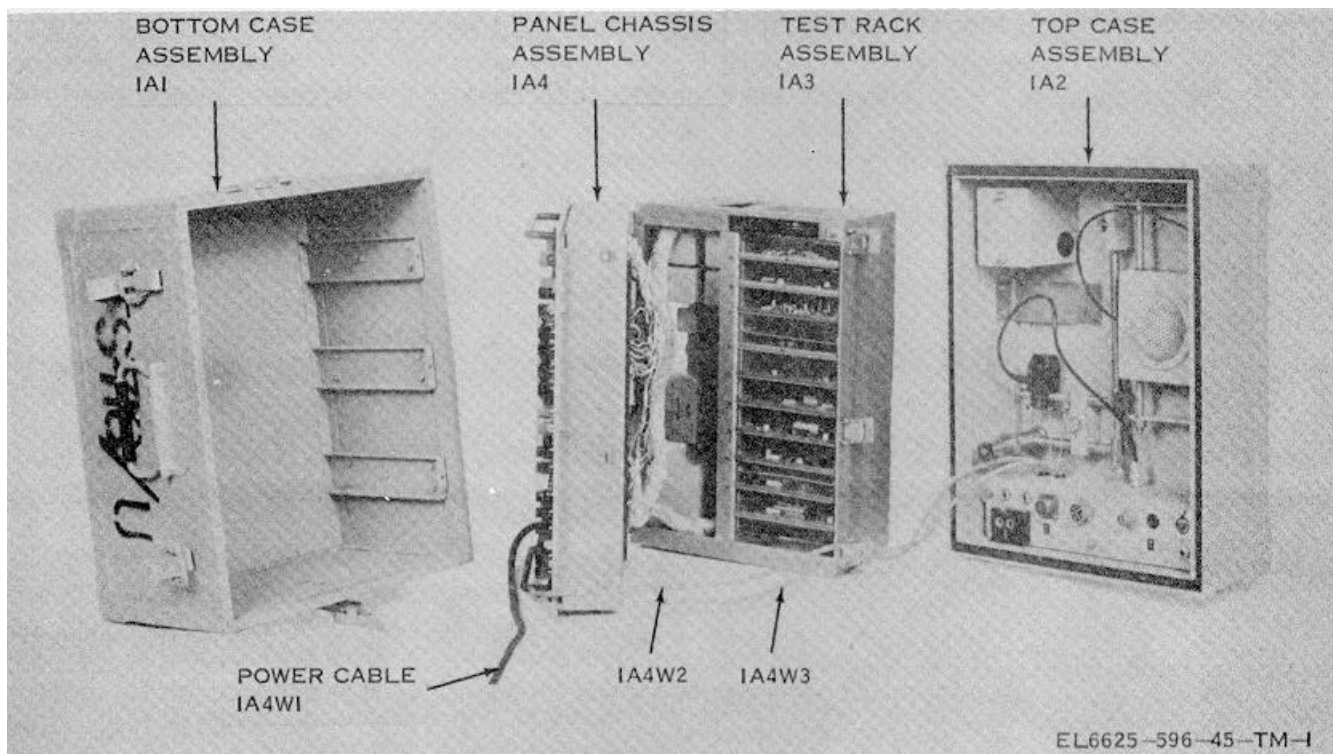

Figure 1-1. Telephone Test Set TS-716/U.

CHAPTER 2

FUNCTIONING OF EQUIPMENT

2-1. General

a. Telephone Test Set TS-716/U (FIG. 1-1) is designed to perform eight different types of tests on all types of transducers and telephone communications equipment. To perform such a wide variety of functions, the test set consists of a number of separate circuits and assemblies which are selected and interconnected by pushbutton and rotary switches.

b. The TB-716/U tests equipment in one or more of the following ways:

(1) By applying a known input signal, either electrical or acoustical, to the equipment under test, and measuring either the electrical or acoustical output of the equipment under test.

(2) By applying an input to the equipment under test which simulates its normal operating condition.

(3) By measuring the output of the equipment under test.

(4) By comparing the equipment under test to a standard circuit in the test set.

2-2. Block Diagram

Figure 6-8 is a simplified block diagram of the TS-716/U. The location of the various controls, circuits, connectors, and assemblies is shown in figures 3-1 through 3-4.

a. *Noise Generator.* Noise generator assembly 1A3A3 produces a random noise signal, with harmonics, that covers the frequency spectrum from 300 to 5, 100 Hertz (Hz).

b. *Power Amplifier.* Power amplifier assembly 1A3A4 raises the output of the noise generator to a nominal level of 1 watt. The power amplifier output is applied to a resistive load and to either test loudspeaker 1A2A2 or to NOISE GEN terminals 1A4E12 and ARTIFICIAL MICROPHONE terminal 1A4E as selected by NOISE GENERATOR switch 1A4S3. The power amplifier may also be applied to EARPHONES panel terminal 1A4E8. RECEIVER LOAD switch 1A4S2 selects the proper resistor network to match the

impedance of the earphone being tested.

c. *Microphone.* Test microphone 1A2A4A4 measures the acoustical output from a receiver to which a known electrical input has been applied from the power amplifier. The output of the test microphone is coupled to LEVEL control A4AT1 by input transformer 1A4T2 when TEST CONDITION switch 1A4S9 is at COUPLER. With 1A4S9 at ART REC or TEL LINE, 1A4T2 is connected to the MICROPHONES panel terminals. MICROPHONE LOAD switch 1A4S2 selects the correct tap on the primary winding of 1A4T2 to match the impedance of the microphone being tested.

d. *LEVEL Controls A and B.* LEVEL controls A (1A4AT1) and B (1A4AT2) are decade ladder type variable attenuators providing a total attenuation of 0 to 110 decibels (dB) in 1-dB steps. The LEVEL attenuators control the input to preamplifier 1A3A1 so that a midscale reading of meter 1A4M1 can always be obtained, regardless of the sensitivity of the microphone or receiver being tested.

e. *Preamplifier.* Microphone preamplifier 1A3A1 provides a fixed gain of 60 dB to raise the level of the weak signals from the microphone ahead of the switching and filter circuits.

f. *Filters.* Filters 1A3FL1 through 1A3FL4 divide the output of the preamplifier into four frequency bands. By measuring the electrical energy in each band, it is possible to determine the frequency response characteristic of a microphone or receiver.

g. *VALUE Controls C and D.* Since the output of a microphone is usually not uniform but increases as frequency increases, VALUE controls 1A4AT3 and 1A4AT4 are placed between the CENTER (1A3FL2) and HIGH (1A3FL3) filters and meter amplifier 1A3A2 to provide additional attenuation in these frequency bands.

Thus, it is possible to obtain a midscale deflection of meter 1A4M1 in all three frequency bands regardless of the shape of the frequency response characteristic of the microphone or receiver being tested. The VALUE controls are 1-dB per step ladder-type variable attenuators.

h. Meter Amplifier. Meter amplifier 1A3A2 raises the signals from the preamplifier and the transmission efficiency circuits to a level adequate for deflection of meter 1A4M1. The meter amplifier includes a full-wave rectifier and logarithmic attenuator. The output of the amplifier is a direct-current (dc) signal proportional to the log-arithm of the alternating-current (ac) input signal. Therefore, the scale of 1A4M1 is a decibel scale during the earphone, microphone, sound power telephone, telephone efficiency, and varistor tests.

i. 20-Hertz Inverter. Inverter 1A3A11 is an electromechanical device which converts 100 volts direct current from the positive power supply to 20-Hertz square wave. The inverter output is applied to TEL LINE terminals L1 and L2 through voltage divider networks (part of 1A3A8) for the ringer and insulation resistance tests.

j. Generator Test. Generator test assembly 1A3A8 provides resistive loads and a full-wave rectifier for the output of hand generators under test. The rectified output of the hand generator is measured by meter 1A4M1.

k. Dial Percent Break Test. Dial break test assembly 1A3A9 contains circuitry to determine the make-to-break ratio of dial switches connected across the TEL LINE terminals. A free-running multivibrator, which generates simulated dial pulses used to calibrate meter 1A4M1 for the dial speed test, is also located on 1A3A9.

l. Dial Speed Test. Dial speed test circuit 1A3A10 produces a direct current which is proportional to the speed of a telephone dial connected across the TEL LINE terminals.

m. Power Supplies. Positive power supply 1A3A5 and negative power supply 1A3A6 convert the 115/230-volt ac line voltage into the various dc voltages required to operate the test set circuitry.

n. Continuity Test. The continuity test circuit indicates when a resistance of less than 10 ohms is connected across its terminals, it is not connected to

1A3T1.

2-3. Noise Generator Assembly 1A3A3 (FIG. 6-10)

Assembly 1A3A3 includes noise generator 1A3A3Q1 and amplifiers 1A3A3Q2 and Q3. Noise generator 1A3A3Q1 is a germanium PNP type of transistor biased to operate in the high-noise region. Voltage divider 1A3A3R1 and R2, connected between the -12-volt supply (pin P of 1A3A3P1) and ground (pin C of 1A3A3P1), provides 1A3A3Q1 base bias current. Resistor 1A3A3R1 is the collector load, and emitter resistor 1A3A3R5 provides negative dc feedback for temperature stabilization. Emitter capacitor 1A3A3C2 bypasses the emitter to ground for ac signals, providing higher gain. The noise output of 1A3A3Q1 is coupled through capacitor 1A3AC1 to the base of 1A3A3Q2. Filter 1A3A3C3 and R4 isolate the -12-volt power source from 1A3A3Q1. Amplifiers 1A3A3Q2 and Q3 are conventional common-emitter amplifiers. The coupling network (1A3A3C4, C5, C7, R10, and R11) between 1A3A3Q2 and Q3 constitutes an equalizing network which insures that the amplitude of the noise signal output is uniform with frequency. The output of 1A3A3 is applied through NOISE GENERATOR CALIBRATE control 1A4R12 to power amplifier assembly 1A3A4.

2-4. Power Amplifier 1A3A4 (FIG. 6-10)

Assembly 1A3A4 is a transformer-coupled, 1-watt power amplifier which includes amplifier 1A3A4Q1, push-pull driver 1A3A4Q2 and Q3, and output transformer 1A3A4T3. Amplifier 1A3A4Q1 is a conventional single-ended, common-emitter amplifier. The output of 1A3A4Q1 is coupled through 1A3A4T1 to push-pull driver 1A3A4Q2 and Q3. The output of the driver is coupled through 1A3A4T2 and pins J, F, H, and K of 1A3A4P1 to power amplifiers 1A3Q1 and Q2. Thermistor 1A3A4RT2 and RT3 provide temperature stabilization of 1A3Q1 and Q2. The output of 1A3Q1 and Q2 is coupled through output transformer 1A3A4TS and pin B of 1A3A4P1 to acoustic output adjustment 1A3R11 and to NOISE GEN ADJ button 1A4S6A, Varistor button 1A4S6F, EARPHONES button 1A4S6G, TELEPHONE EFFICIENCY-RECEIVE button 1A4S6P, and TELEPHONE EFFICIENCY-SEND button 1A4S6R. Acoustical output adjustment 1A3R11 is adjusted (para 4-3) so that the sound pressure at loudspeaker 1A2A2 is 20 dynes/cm². Negative 30 volts is applied to assembly 1A3A4 at pin M of 1A3A4P1.

2-5. Preamplifier 1A3A1 (FIG. 6-10)

Preamplifier 1A3A1 amplifies the microphone input from either test microphone 1A2A4A4, MICROPHONE CARBON terminal 1A4E1, MICROPHONE OTHER TYPE terminal 1A4E3, or one of the test receptacles on electrical test panel 1A2A14. The microphone input to 1A3A1 is applied through MICROPHONE LOAD switch 1A4S9, transformer 1A4T2, and LEVEL controls A and B (1A4AT1 and 1A4AT2) to pin L of 1A3A1P1. Preamplifier 1A3A1 includes three common-emitter amplifiers 1A3A1Q1, Q2, and Q3. The output of amplifier 1A3A1Q1 is coupled through 1A3A1C4 to 1A3A1Q2 and the output of 1A3A1Q2 is direct-coupled to 1A3A1Q3. Feedback resistor 1A3A1R9 and feedback network 1A3A1R16, C5, R15, R12, and R5 compensate for variations in temperature and component aging to maintain a constant gain of 60 dB. Filters 1A3A1C3, R6, C7, and R13 provide power supply decoupling between stages. Negative 12 volts is applied to assembly 1A3A1 at pin C of 1A3A1P1. The output of 1A3A1 at pin A of 1A3A1P1 is applied through either LOW, CENTER, HIGH, or NARROW BAND button (1A4S5B, C, D, or E) and filter 1A3FL1, FL2, FL3, or FL4 to meter amplifier 1A3A2. Fixed 16-dB attenuator 1A3A1R18, R19, and R20 is inserted between filter 1A3FL1 and 1A3A2, VALUE C attenuator (1A4AT3) is inserted between 1A3FL2 and 1A3A2, and VALUE D attenuator (1A4AT4) is inserted between 1A3FL3 and 1A3A2.

2-6. Meter Amplifier Assembly 1A3A2 (FIG. 6-10)

Assembly 1A3A2 amplifies the microphone output of preamplifier 1A3A1 (para 2-5) or the simulated receiver output of transmission efficiency assembly 1A3A7 (para 2-8). The input to 1A3A2, which is applied to pin S of 1A3A2P1, is amplified by three common-emitter amplifiers 1A3A2Q1, Q2, and Q3. The output of 1A3A2Q3 is applied through 1A3A2C9 to METER SENSITIVITY CALIBRATE control 1A4R14 to complementary symmetrical output amplifier 1A3A2Q4, Q5, and Q6. The symmetrical output of the output amplifier is applied through 1A3A2C10 to full-wave bridge rectifier 1A3A2CR1, CR2 and CR3, and 1A3A8CR4. Diode 1A3A8CR4 is connected to 1A3A2CR1, CR2, and CR3 through pin F of 1A3A2P1, contacts on 1A4S6, and pin C of 1A3A8P1. The dc output of the rectifier is applied to logarithmic attenuator 1A3A2CR4. Because of the conduction characteristics of forward-biased germanium diode 1A3A2CR4, the

output across 1A3A2CR4 (between pins C and F of 1A3A2P1) is proportional to the logarithm of the input at pin S of 1A3A2P1. The dc output across 1A3A2CR4 is applied through meter amplitude gain adjustment 1A3R16 (para 4-4) and contacts on 1A4S6 to meter 1A4M1. Thermistor 1A3A2RT1 provides temperature stabilization. Negative 30 volts is applied to assembly 1A3A2 at pin B of 1A3A4P1.

2-7. Ring Generator Assembly 1A3A8 (FIG. 6-10)

Assembly 1A3A8 consists of 18 load resistors and full-wave bridge rectifier 1A3A8CR1 through 1A3A8CR4.

a. Resistors 1A3A8R5, R6, and R7 form a load for testing hand generators. The load is connected to TEL LINE terminal L1 when HAND GENERATOR button 1A4S6B is pressed. Resistor 1A3A8R19 is added to the load when TEST button 1A4S5A is pressed.

b. Resistors 1A3A8R2, R3, R10, and R12 form voltage divider networks which provide minimum operating currents for 2,400-, 5,300-, and 12,000-ohm ringers. Resistors 1A3A8R1 and 1A3A8R4 also form a voltage divider for ringer tests. When one of the RINGER buttons (1A4S6C, D, or E) is pressed, the voltage developed across 1A3A8R4 (pin E, 1A3A8P1) is applied through closed contacts of the pressed switch, and pin A of 1A3A8P1 to full-wave bridge rectifier 1A3A8CR1 through CR4. The dc output of the rectifier at pin B of 1A3A8P1 is applied through contacts on 1A4S6 to meter 1A4M1 to give a visual indication that the ringer test circuit is operating.

c. Resistor 1A3A8R11 is part of the insulator resistance test circuit. When INSULATION RESISTANCE button 1A4S6N is pressed, 1A3A8R11 is series-connected with INSULATION RESISTANCE control 1A4R13 and inserted between the output at pin 3 of 20-Hertz inverter 1A3A11 and bridge rectifier 1A3A8CR1 through CR4.

d. Resistors 1A3A8R17 and R18 form a voltage divider for calibration of the sensitivity of meter amplifier assembly 1A3A2. The output of power amplifier 1A3A4 (pin B, 1A3A4P1) is applied to 1A3A8R17 and R18 in series, and the voltage across 1A3A8R18 is applied to pin S of meter amplifier 1A3A2.

e. Resistors 1A3A8R14, R15, and R16 form a

voltage divider network used in adjusting NOISE GENERATOR CALIBRATE control 1A4R12. When NOISE GEN ADJ button 1A4S6A is pressed, the output of power amplifier 1A3A4 (pin B, 1A3A4P1) is applied to 1A3A8R14 and R16 in series, and the voltage across 1A3A8R16 is applied through 1A3A8R15 to bridge rectifier 1A3A8CR1 through CR4. f. Resistors 1A3A8R8 and R9 form a voltage divider used to measure the bias current applied to carbon microphones. When READ MICRO-PHONE CURRENT button 1A4S5F is pressed, the 1A3A3R8 is parallel-connected with the microphone, and the voltage across 1A3A8R8 is applied to 1A3A8R9 in series with meter 1A4M1.

2-8. Transmission Efficiency Assembly 1A3A7
(FIG. 6-10)

Assembly 1A3A7 electrically simulates physical telephone line conditions for the telephone efficiency and varistor tests.

a. Resistors 1A3A7R1 and R2 and capacitor 1A3A7C1 simulate a telephone transmitter by applying a portion of the output from power amplifier 1A3A4 to ARTIFICIAL MICRO-PHONE terminals 1A4E4 and E5. When TELE-PHONE EFFICIENCY-SEND button 1A4S6R is pressed, the output of power amplifier 1A3A4 at pin B, 1A3A4P1 is applied to 1A3A7C1, R2, and R1 in series, and the signal developed across 1A3A7R1 is applied to MICROPHONE TERMINALS 1A4E4 and E5.

b. Resistor 1A3A7R9 is the load resistor for the output of power amplifier 1A3A4 when NOISE GENERATOR switch 1A4S3 is at LOAD. When 1A4S3 is at LOAD, the output of power amplifier 1A3A4 at pin B of 1A3A4P1 is applied to acoustical output adjust 1A3R11 in series with 1A3A7R9.

c. Resistors 1A3A7R3 through R6 simulate a telephone receiver for telephone efficiency and varistor tests. Transformer 1A3A7T1, the primary of which is connected to ARTIFICIAL RECEIVER terminals 1A4E6 and E7, provides dc isolation for terminals 1A4E6 and E7. The signal applied to terminals 1A4E6 and E7 is applied through 1A3A7T1 to 1A3A7R4 in parallel with the series resistance of 1A3A7R5 and R6. When TEST CONDITION switch 1A4S9 is at ART REC, the signal developed across 1A3A7R6 is applied to LONG LINE button 1A4S7A and SHORT LINE BUTTON 1A4, S7B. When 1A4S7A is pressed, the signal is applied through VALUE C control 1A4AT3 to meter amplifier assembly

1A3A2. When 1A4S7B is pressed, the signal is applied through VALUE D control 1A4AT4 to 1A3A2.

d. Resistors 1A3A7R7 and R8 simulate short-line and long-line loading conditions for tele-phones connected to TEL LINE terminals L1 and L2. When SHORT LINE button 1A4S7B is pressed, TEL LINE terminal L1 is connected to 1A3A7R7. When LONG LINE button 1A4S7A is pressed, TEL LINE terminal L1 is connected to 1A3A7R8.

2-9. Dial Percent Break Assembly 1A3A9
(FIG. 6-10)

Assembly 1A3A9 produces a direct current that is proportional to the make-to-break ratio of a telephone dial switch connected to TEL LINE terminals L1 and L2.

a. When DIAL BREAK button 1A4S6L is pressed, +24 volts from positive power supply 1A3A5 (pin H of 1A3A5P1) is applied through contacts 7 and 8 of 1A4S6L to pin D of 1A3A9P1. Positive 24 volts at pin D causes current to flow from ground through 1A3A9R7, CR1, R6, and R5, and from ground through pin E of 1A3A10P1, 1A3A10R11, DIAL BREAK CALIBRATE control 1A4R18, contacts 2 and 3 of 1A4S6L, 1A4M1, pin J of 1A3A9P1, 1A3A9R8, CR2, CR1, R6, and R5. DIAL BREAK CALIBRATE control 1A4R18 can be adjusted for a midscale reading on 1A4M1. Capacitor 1A3A9C4 charges to the voltage across 1A3A9R7. When TEST button 1A4S5A is pressed, contacts 3 and 4 of 1A4S5A short 1A3A9R6 (pins F and L of 1A3A9P1), and TEL LINE terminal L1 is connected through pin K of 1A3A9P1, 1A3A9CR3, pin H of 1A3A9P1, and contacts 1 and 2 of 1A4S5A to pin L of 1A3A9P1. When the telephone dial switch that is connected to TEL LINE terminals L1 and L2 (ground) is operated (the contacts alternately make and break), L1 and L2 alternately short and open, causing 1A3A9C4 to charge and discharge. Therefore, the current flow through 1A4M1 is proportional, to the make-to-break ratio of the dial switch.

b. Assembly 1A3A9 also contains free-running multivibrator 1A3A9Q1 and Q2 which generates simulated dial pulses available at pin C of 1A3A9P1. The period (time between pulses) which is determined by the time constant of 1A3A9R3, C3, and dial speed adjustment 1A3R15,

is adjusted to .050 seconds (para 4-6). The simulated dial pulse output at pin C of 1A3A9P1 is applied to dial speed assembly 1A3A10 (pin J of 1A3A10P1). Plus 10 volts is applied to 1A3A9Q1 and Q2 through pin A of 1A3A9P1.

2-10. Dial Speed Assembly 1A3A10
(FIG. 6-10)

Assembly 1A3A10 includes monostable multivibrator 1A3A10Q1 and Q2, which is triggered by pulses from either dial percent break assembly 1A3A9 or the telephone dial switch connected to TEL LINE terminals L1 and L2. When TEST button 1A4S5A is *not* pressed, pulses from pin C of 1A3A9P1 are applied through pin J of 1A3A10P1, 1A3A10R2, pin L of 1A3A10P1, contacts 7 and 8 of 1A4S5A, pin K of 1A3A10P1, and 1A3A10CR1 to the base of 1A3A10Q1 to trigger the multivibrator. When TEST button 1A4S5A and DIAL SPEED button 1A4S6M are pressed, TEL LINE terminal L2 is connected through contacts 2 and 3 of 1A4S6M, pin P of 1A3A10P1, pin R of 1A3A9P1, pin R of 1A3A10P1, 1A3A10C2 and R4, pin N of 1A3A10P1, contacts 9 and 8 of 1A4S5A, and pin K of 1A3A10P1. When the telephone line switch that is connected to L1 and L2 is operated (the contacts alternately make and break), the 24 volts connected from pin H of 1A3A5P1, contacts 10 and 11 of 1A4S6M, pin E of 1A3A9P1, 1A3A9R9, pin K of 1A3A9P1 to L1, is alternately applied to terminal L2 to trigger the multivibrator. The period (time between pulses) of the multivibrator output is determined by the time constant of 1A3A10C3 and R8. The time constant is such that the multivibrator is triggered on only every other dial pulse. The amplitude of the output of the multivibrator is controlled by DIAL SPEED CALIBRATE control 1A4R17. The output of the multivibrator at the variable arm (pin 2) of 1A3R17 is integrated by 1A3A10R13 and C4. When DIAL SPEED button 1A4S6M is pressed, the integrated output is applied through 1A3A10CR2, CR3, and CR4 in series. The pulsating voltage across 1A3A10CR4 is applied through 1A3A10R15 in series with 1A3A10C5. The dc voltage across 1A3A10C5 is applied through 1A10R14, contacts 9 and 8 of 1A4S6M to meter 1A4M1 to give visual indication of the dial speed. Plus 10 volts is applied to the multivibrator through pin M of 1A3A10P1.

2-11. Positive Power Supply Assembly 1A3A5
(FIG. 6-10)

a. Assembly 1A3A5 provides the following dc voltages.

- (1) Plus 24 volts at pin H. of 1A3A5P1.
- (2) Plus 10 volts at pin F. of 1A3A5P1.
- (3) Plus 100 volts at pin D. of 1A3A5P1.

b. The 75-volt ac input between pins P and S of 1A3A5P1 is rectified by 1A3A5, CR1 and CR2 and filtered by 1A3A5R1 through R4 and C1 through C4 to produce +24 volts at pin H of 1A3A5P1 and +10 volts at pin F of 1A3A5P1. Ten-watt zener diode 1A3CR2 regulates the +24-volt output, and choke 1A3L1 provides additional filtering for the +24 volts applied as carbon microphone bias.

c. The 150-volt ac input between pins B and E of 1A3A5P1 is rectified by 1A3A5CR3 and CR4 and filtered by 1A3A5R5 and C5 to produce +100 volts at pin D of 1A3A5P1. The +100-volt output at pin D is fused by 1A3F1.

2-12. Negative Power Supply Assembly 1A3A6
(FIG. 6-10)

a. Assembly 1A3A6 provides the following dc voltages.

- (1) Negative 30 volts at pin A of 1A3A6P1.
- (2) Negative 12 volts at pins H and C of 1A3A6P1.

b. The 76-volt ac input between pins S and M of 1A3A6P1 is rectified by 1A3A6CR1 and CR2 and filtered by 1A3A6Ri through R4, C1 through C5, and CR3 and CR4 to produce -30 volts at pins A and B of 1A3A6P1 and 12 volts at pins H and C. Ten-watt zener diode 1A3CR1, which is connected between pin B of 1A3A6P1 and ground, regulates the negative 30-volt output; 100-milliwatt (mw) zener diodes 1A3A6CR3 and CR4 regulate the negative 12-volt outputs at pins H and C, respectively.

**CHAPTER 3
TROUBLESHOOTING**

3-1. General Instructions

a. Several features of the TS-716/U make conventional troubleshooting techniques undesirable. Among these features are:

(1) A complex switching arrangement which simplifies operation but complicates troubleshooting.

(2) The use of printed circuit modules for most of the electronic circuitry enables the substitution of a module that is known to be good for one which is suspected of being faulty.

(3) The use of highly reliable transistorized circuits, which means that most failures will more likely be due to failures of wiring and switches, rather than the failure of electronic components.

b. The first step in servicing a defective TS-716/U is to localize the fault, which means tracing the fault to a defective stage, assembly, or circuit, based on abnormal indications. The second step is isolation, which means locating the defective part or parts.

(1) *Visual inspection.* Some defective parts may be located by sight, smell, or hearing. Burned resistors, arched shorted transformers, or the nonbuzzing of 20-Hertz inverter 1A3A11 may be located by the senses. The meter reading should be observed and an attempt made to localize the fault.

(2) *Operational tests.* Operational tests frequently indicate the location of trouble. The daily maintenance service and inspection chart (TM 11-6625-596-12) contains operational tests.

c. The troubleshooting chart in paragraph 3-3b is based upon the daily preventive maintenance checks and services chart and the troubleshooting chart in TM 11-6625-596-12. Signal tracing, continuity testing, short-circuit test and signal substitution techniques are all used in the order most suitable for locating trouble at a particular step in the checklist.

d. If organizational maintenance personnel have localized the trouble by following the daily preventive maintenance and the trouble-shooting chart, the GS or depot repairman may begin at that step. Otherwise, he should begin at the first step and perform each step in succession. The steps are arranged to quickly eliminate large portions of the test set as a possible source of trouble. Skipping steps will leave portions of the test set untested.

e. This equipment is transistorized. Observe all precautions given to prevent transistor damage. Make voltage and resistance measurements in this equipment only as specified. When measuring voltages, use tape or sleeving to insulate the entire test prod, except the extreme tip. A momentary short circuit can ruin a transistor. Use resistor and capacitor color codes (FIG. 6-7) to find the value of components not otherwise marked. Use voltage and resistance charts in paragraphs 3-4, 3-5, and 3-6 to find the normal readings and compare the normal readings with the readings obtained.

f. In all tests, the possibility of intermittent troubles should not be overlooked. If present, this type of trouble often may be made to appear by tapping or jarring the equipment. Check the wiring and connections to, and within, the test set.

3-2. Test Equipment Required

The following chart lists test equipment required for troubleshooting the TS/716/U. Also listed are the associated technical manuals and the assigned common names.

<i>Test equipment</i>	<i>Technical manual</i>	<i>Common name</i>
Multimeter AN/URM-105 with Multi-meter ME-77/U.	TM 11-6625-203-12	Voltohmmeter.
Signal Generator TS-382/U	TM 11-6625-261-12	Audio oscillator.
Multimeter TS-352B/U	TM 11-6625-366-15	Multimeter.

<i>Test equipment</i>	<i>Technical manual</i>	<i>Common name</i>
Voltmeter ME-30/U----- voltmeter (vtvm).	TM 11-6625-320-12-----	Vacuum tube
Test Set, Transistor TS-1836B/U-----	TM 11-6625-539-15-2-----	Transistor tester.
Tool Kits, Electronic Equipment TK- 105/G and TK-100/G.		
Oscilloscope AN/USM-140-----	TM 11-6625-535-15—5-----	Oscilloscope.

3-3. Troubleshooting Chart

a. *Use of Chart.* The first column of the trouble-shooting chart lists the action performed and possible abnormal indication resulting. The second column lists a possible cause of the abnormal indication.

Where the second column indicates “no signal at . . .” and describes the signal, use the oscilloscope to check for presence of the signal. Where the second column indicates “no voltage at . . .” and lists a voltage, use the

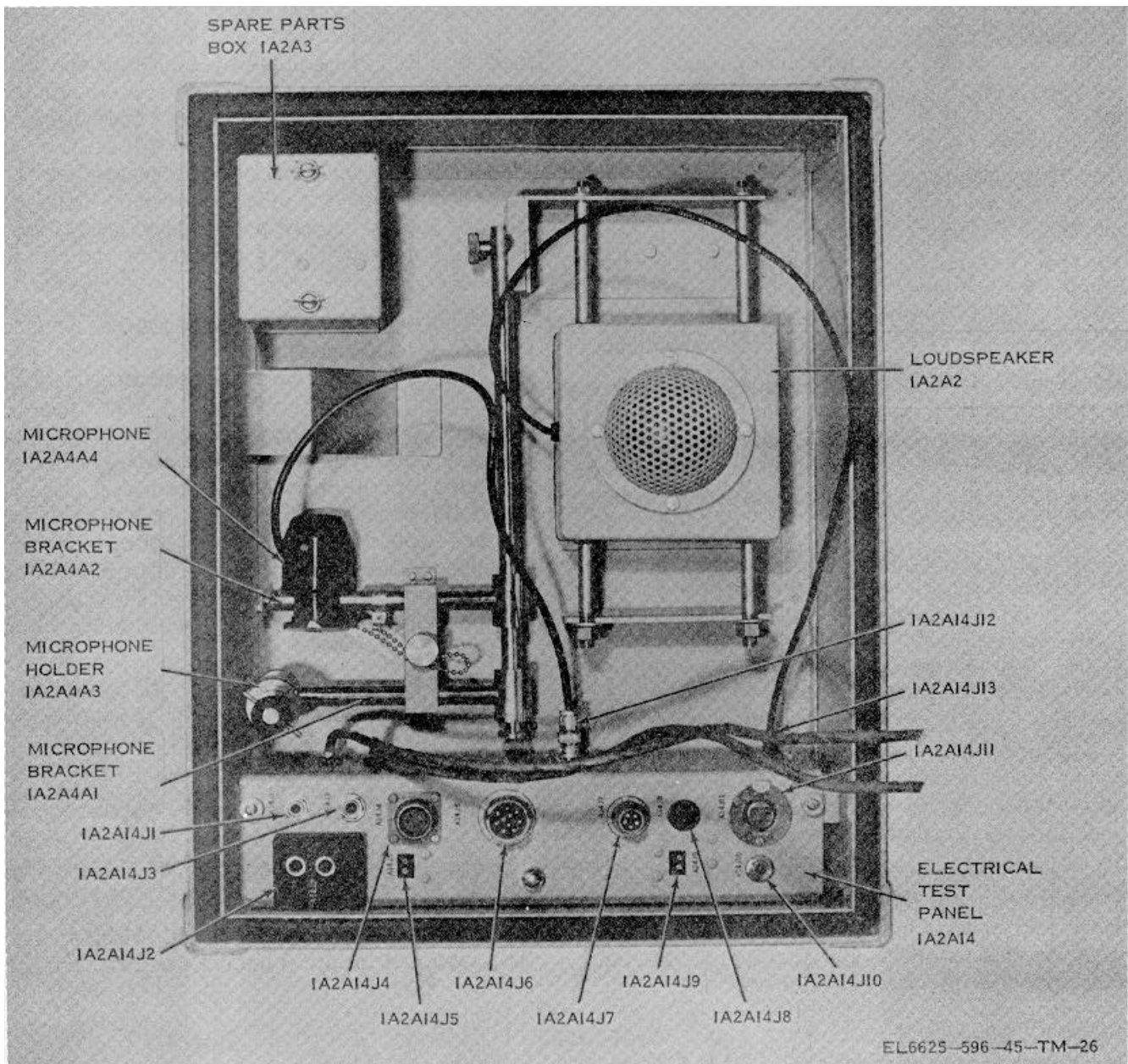

Figure 3-1. Top case assembly 1A2.

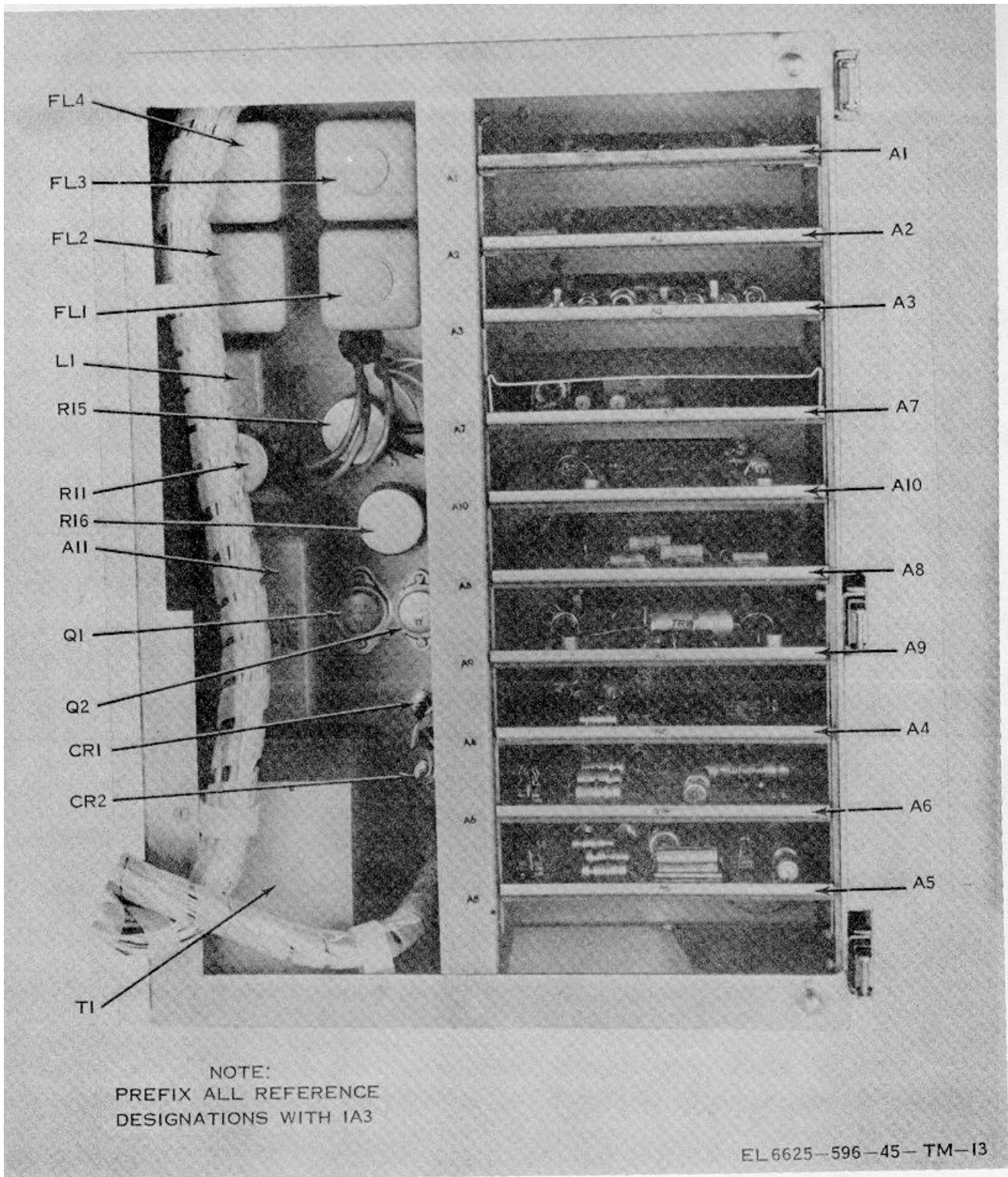

Figure 3-2. Test rack assembly 1AB, front view.

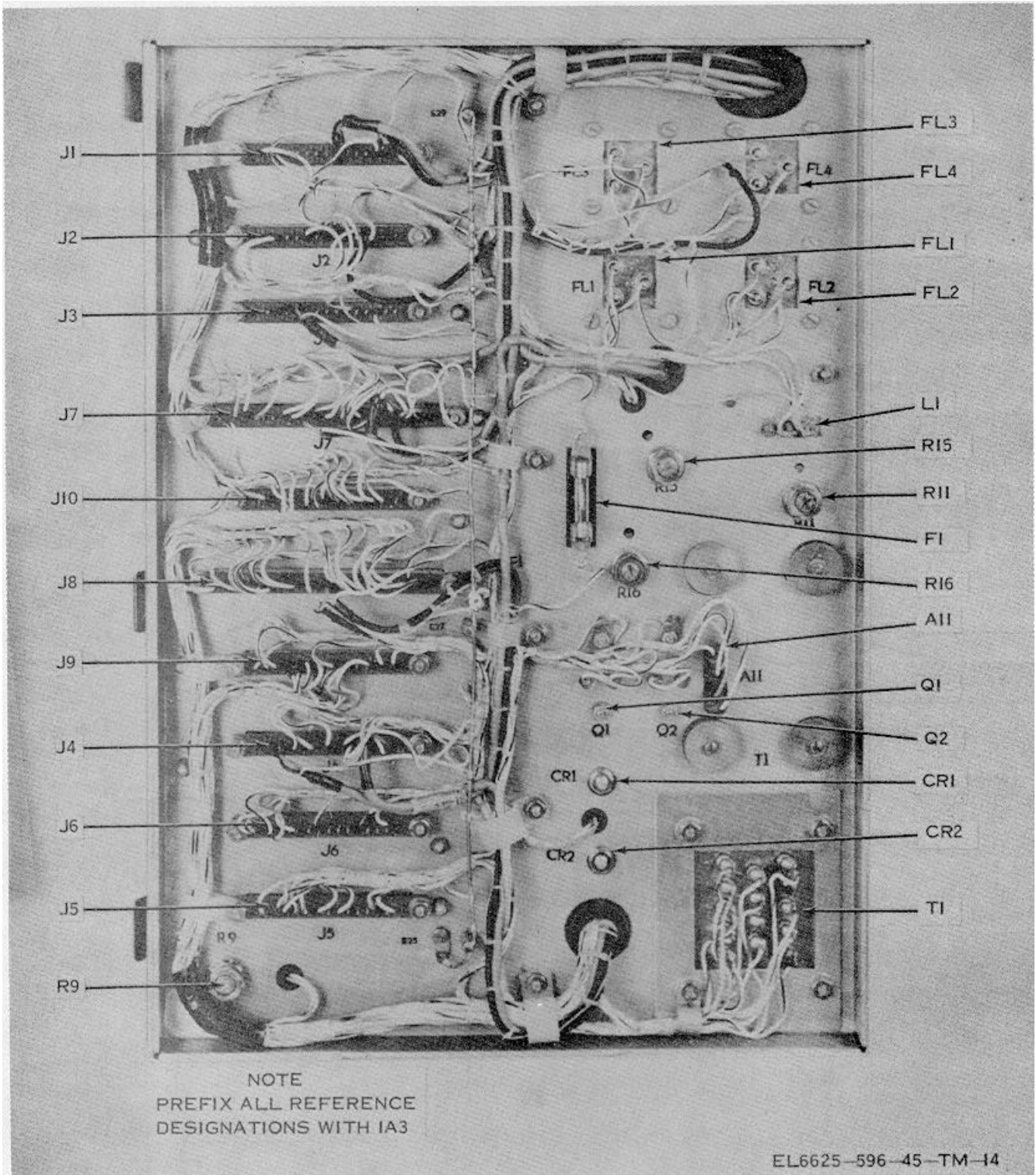

Figure 3-3. Test rack assembly 1A8, rear view.

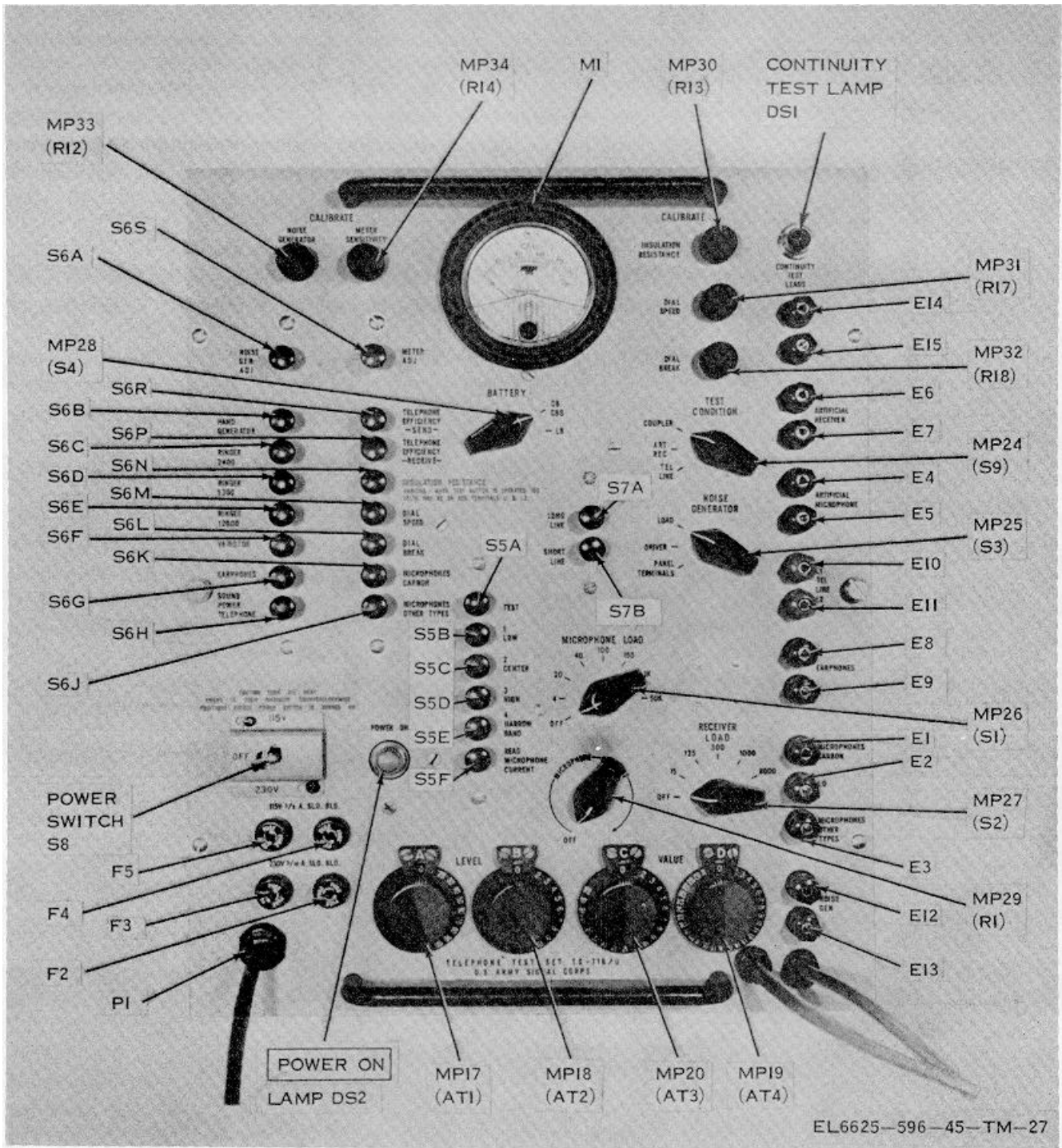

Figure 3-4. Panel chassis assembly 1A4, front view.

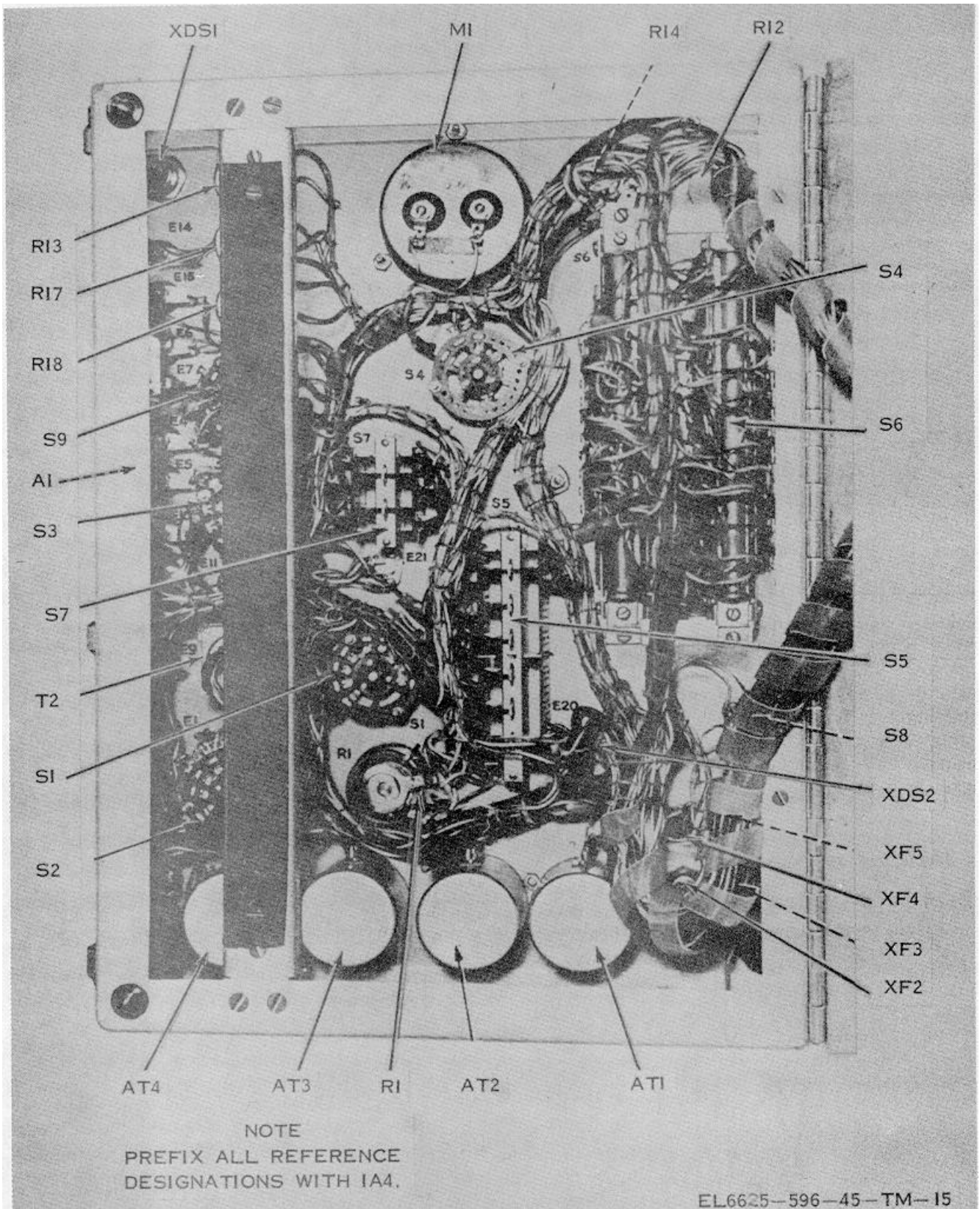

Figure 3-5. Panel chassis assembly 1A4, rear view.

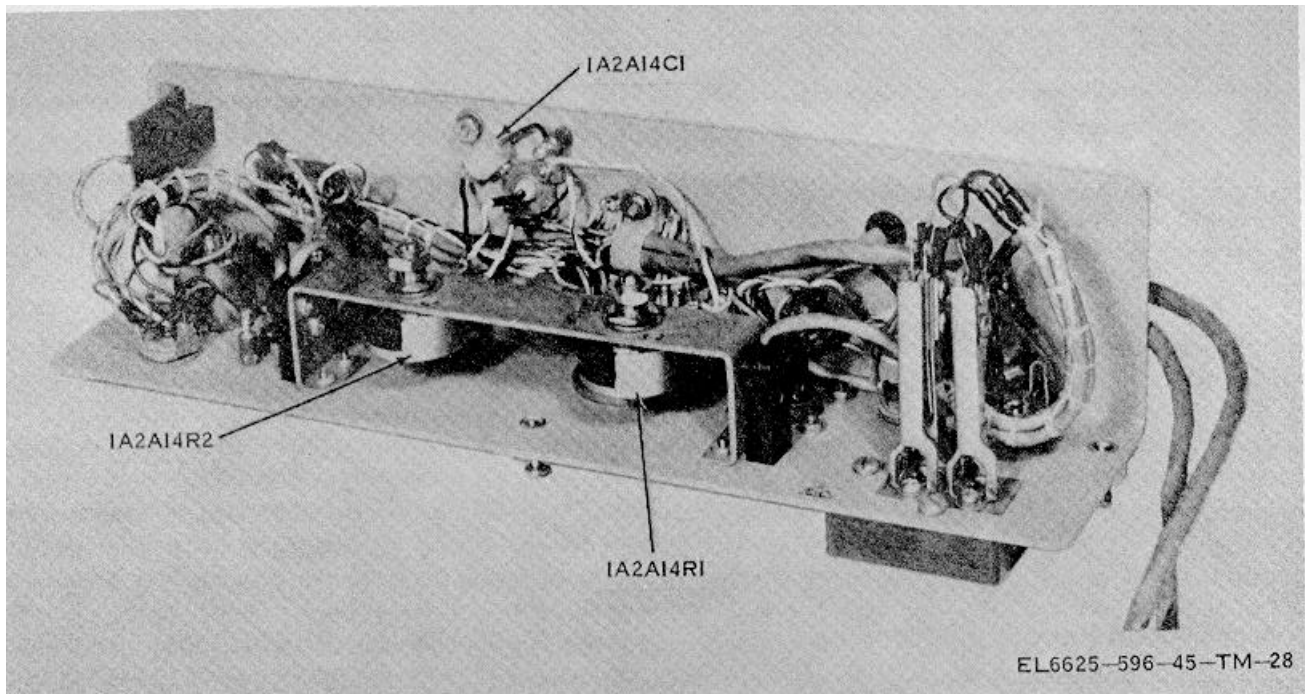

Figure 3-6. Electrical test panel 1A2A14, bottom view.

multimeter to check the voltage at that point. If the signal or voltage is not present, the third column lists the steps to be taken to localize the fault. Make all continuity checks and short circuit tests with the volt-ohmmeter. Turn off the power to the test set during these tests. Do not attempt to use the continuity test circuit of the test set for making continuity tests.

CAUTION

The test set contains many polarized tantalum electrolytic capacitors. Applying a voltage of the wrong polarity to these capacitors will damage or destroy them. Always make continuity or short-circuit checks in the direction given in the instructions. If in doubt about the

direction, remove the printed circuit boards before making tests. The controls, connectors, piece parts, and plug-in assemblies cited in the troubleshooting chart are called out on figures 3-1 through 3-6. The piece parts on plug-in assemblies 1A3A1 through 1A3A10 are called out on figures 3-7 through 3-16. The terminals on switches 1A4S5, S6, and S7 are called out on figures 3-17, 6-9, and 3-18, respectively. Pin locations on 1A3J1 through 1A3J10 are illustrated on figure 6-10.

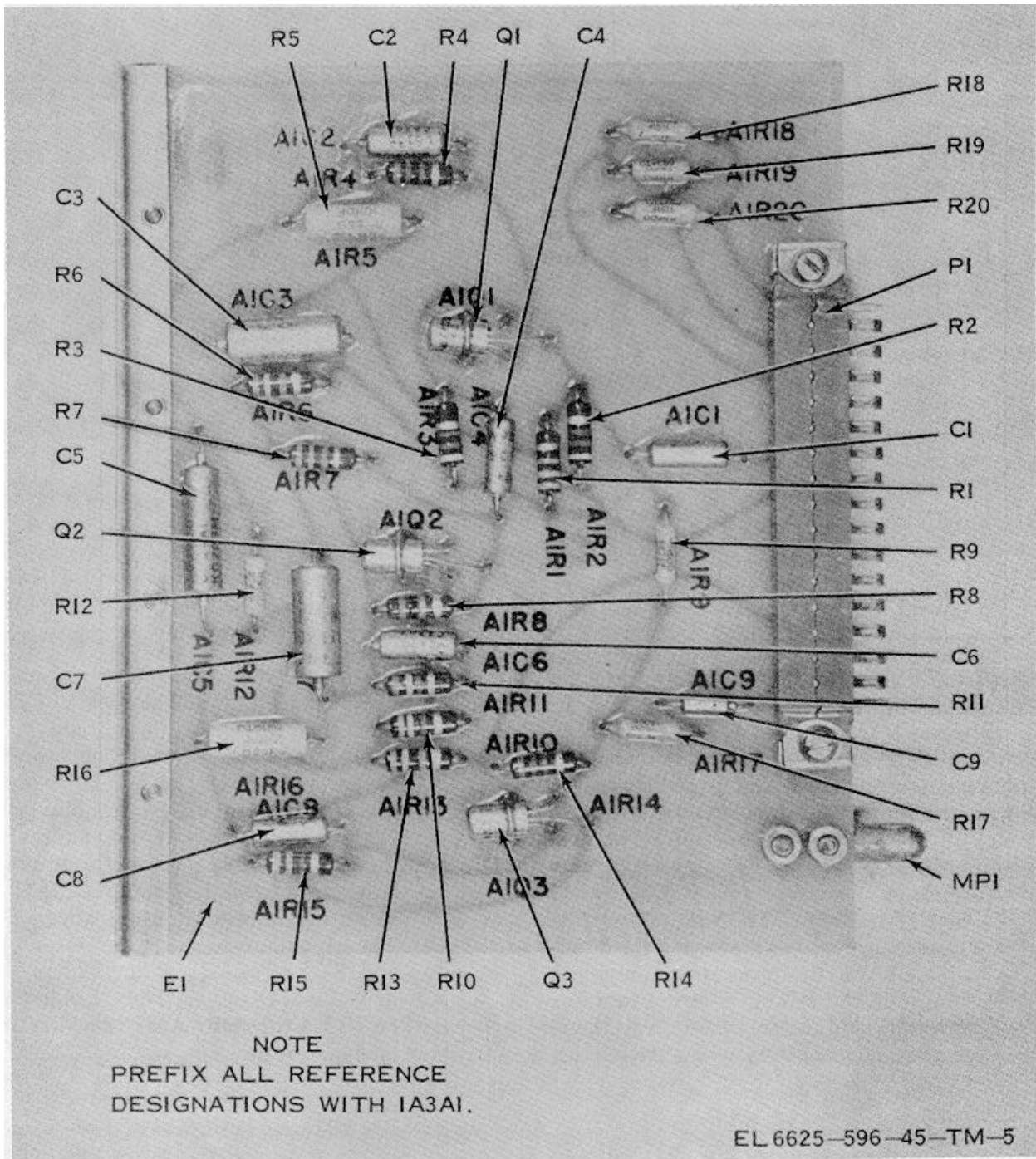

Figure 3-7. Preamplifier assembly 1A3A1, parts location

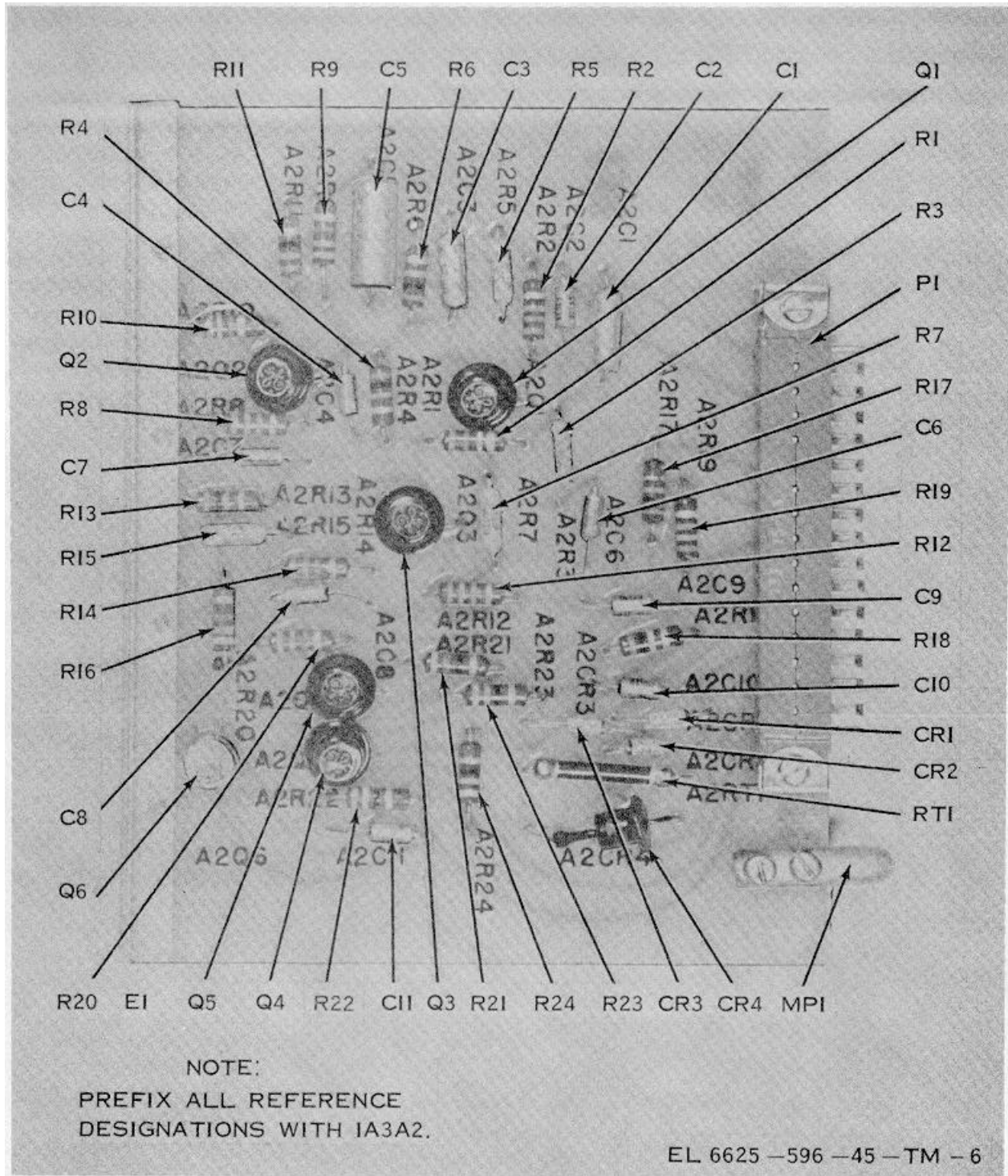

Figure 3-8. Meter amplifier assembly 1A3A2, parts location.

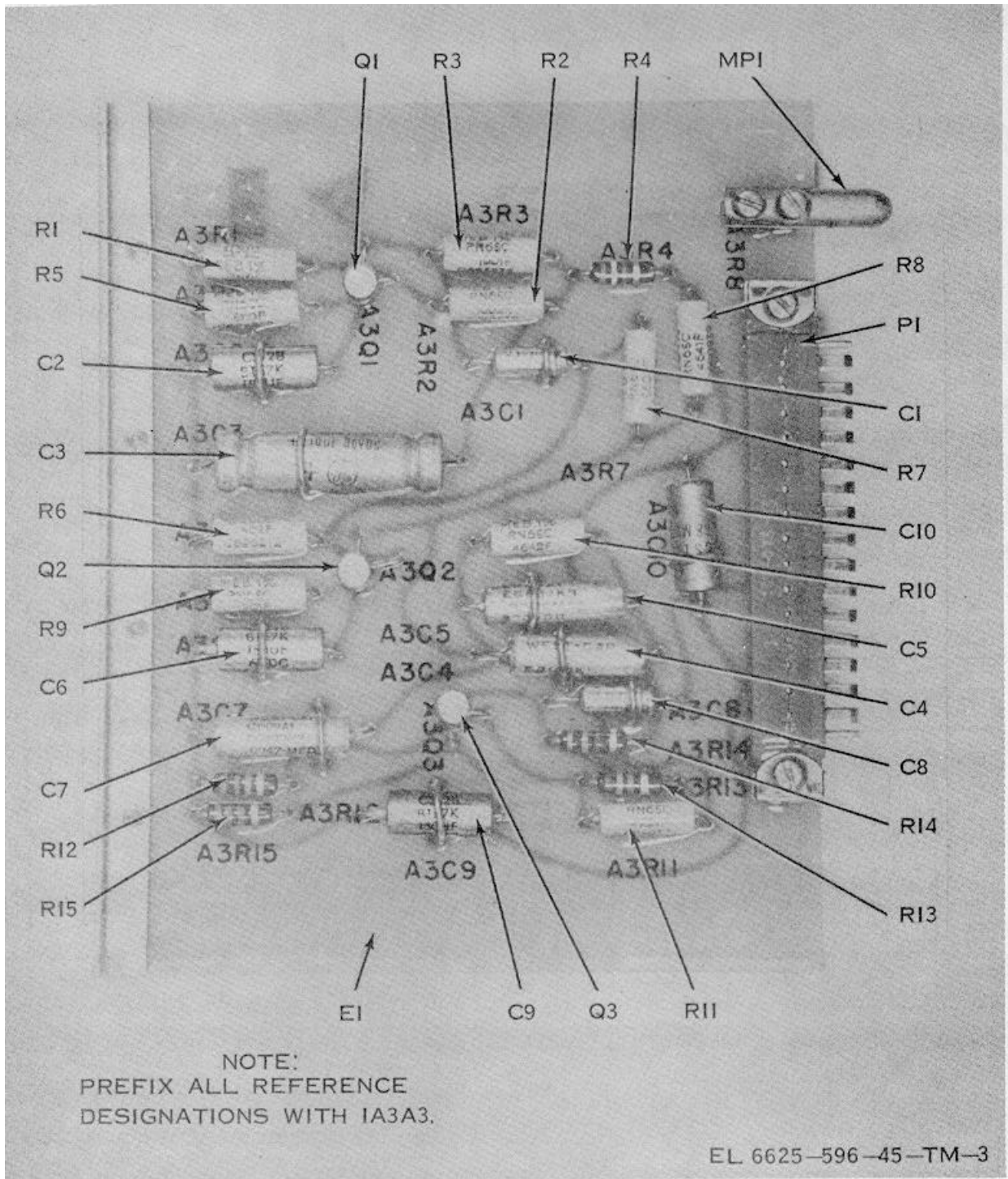

Figure 3-9. Noise generator assembly 1A3A3, parts location.

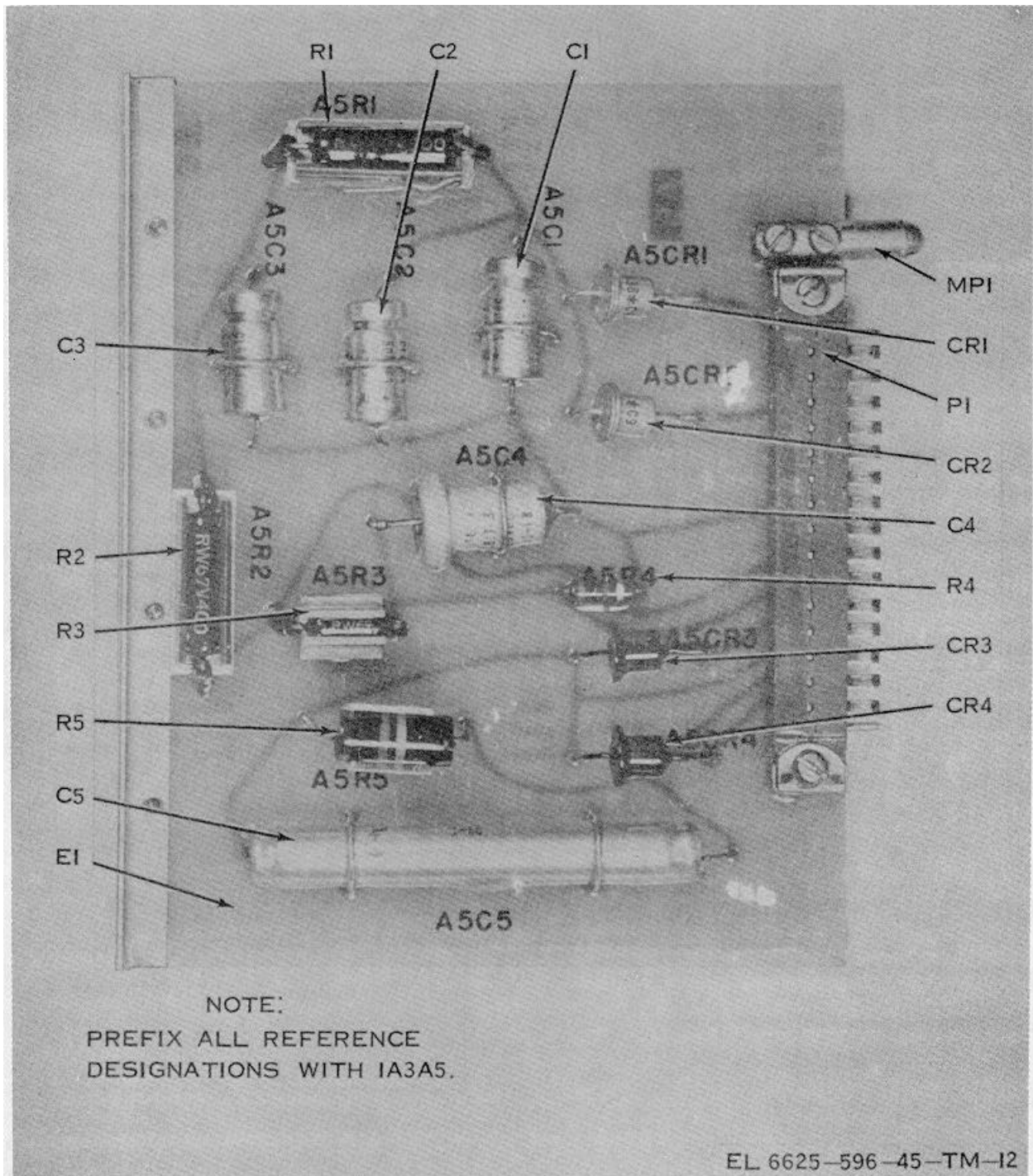

Figure 3-11. Positive power supply assembly 1A3A5, parts location.

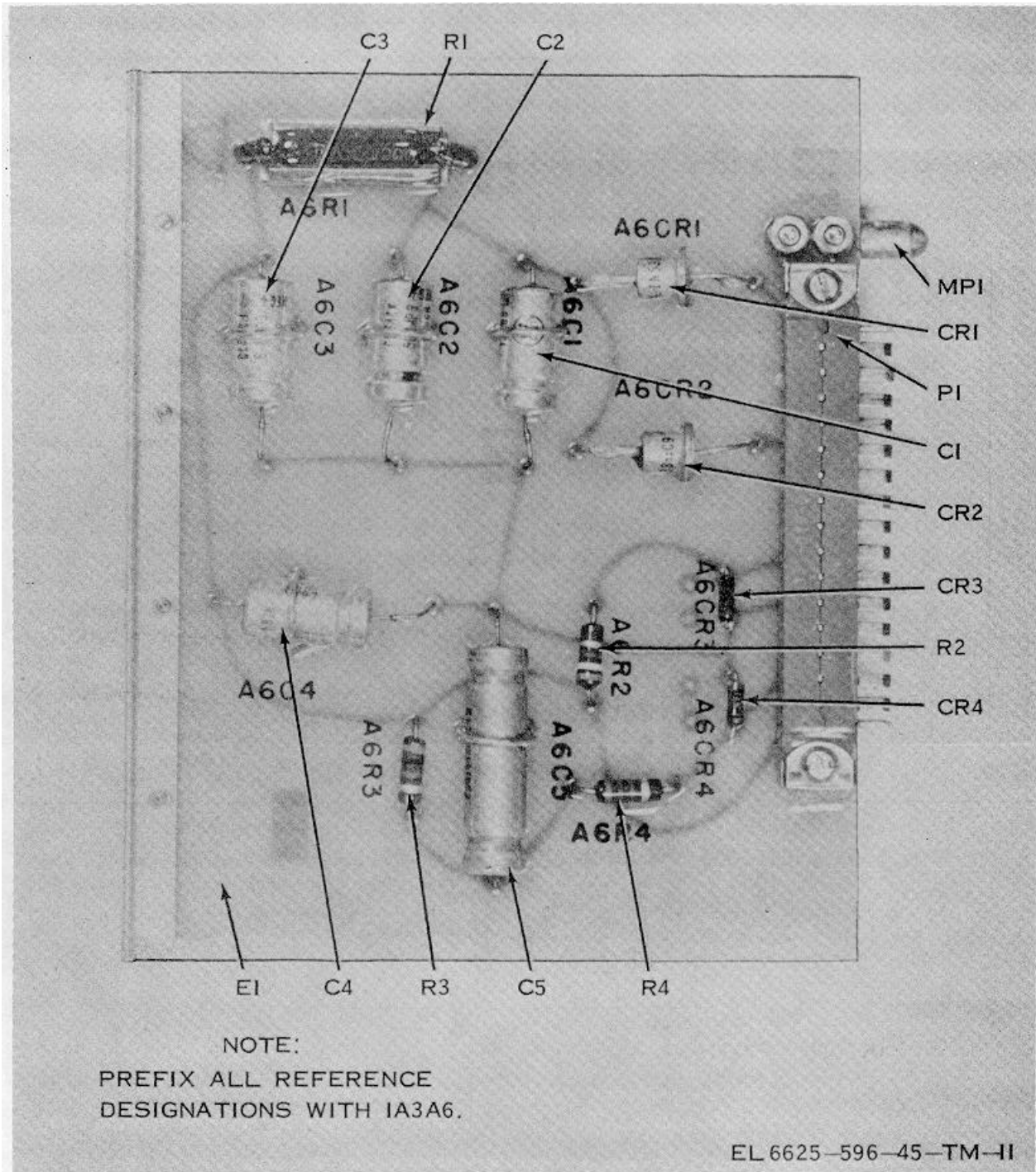

Figure 3-12. Negative power supply assembly 1A3A6, parts location.

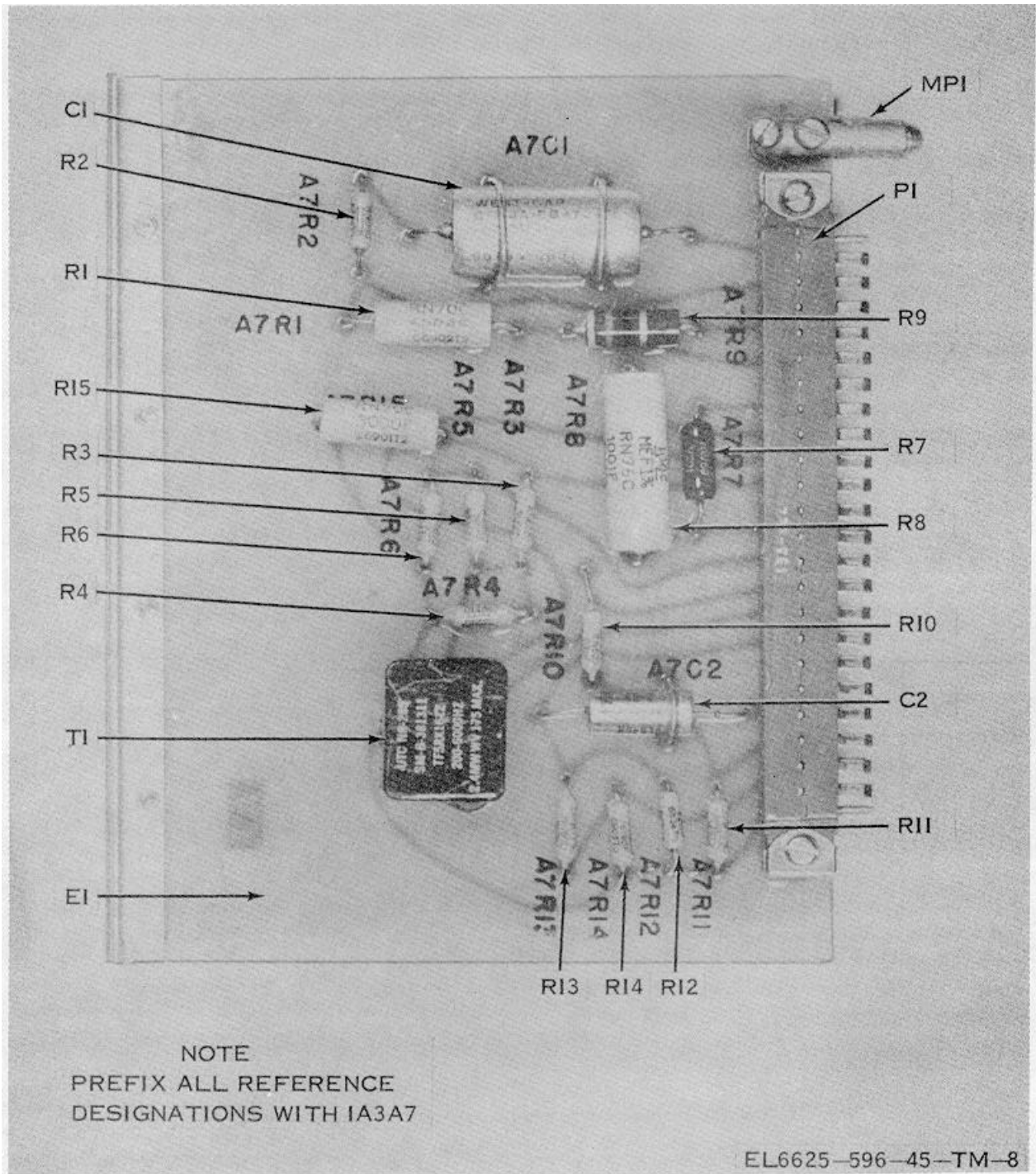

Figure 3-13. Transmission efficiency assembly 1A3A7, parts location.

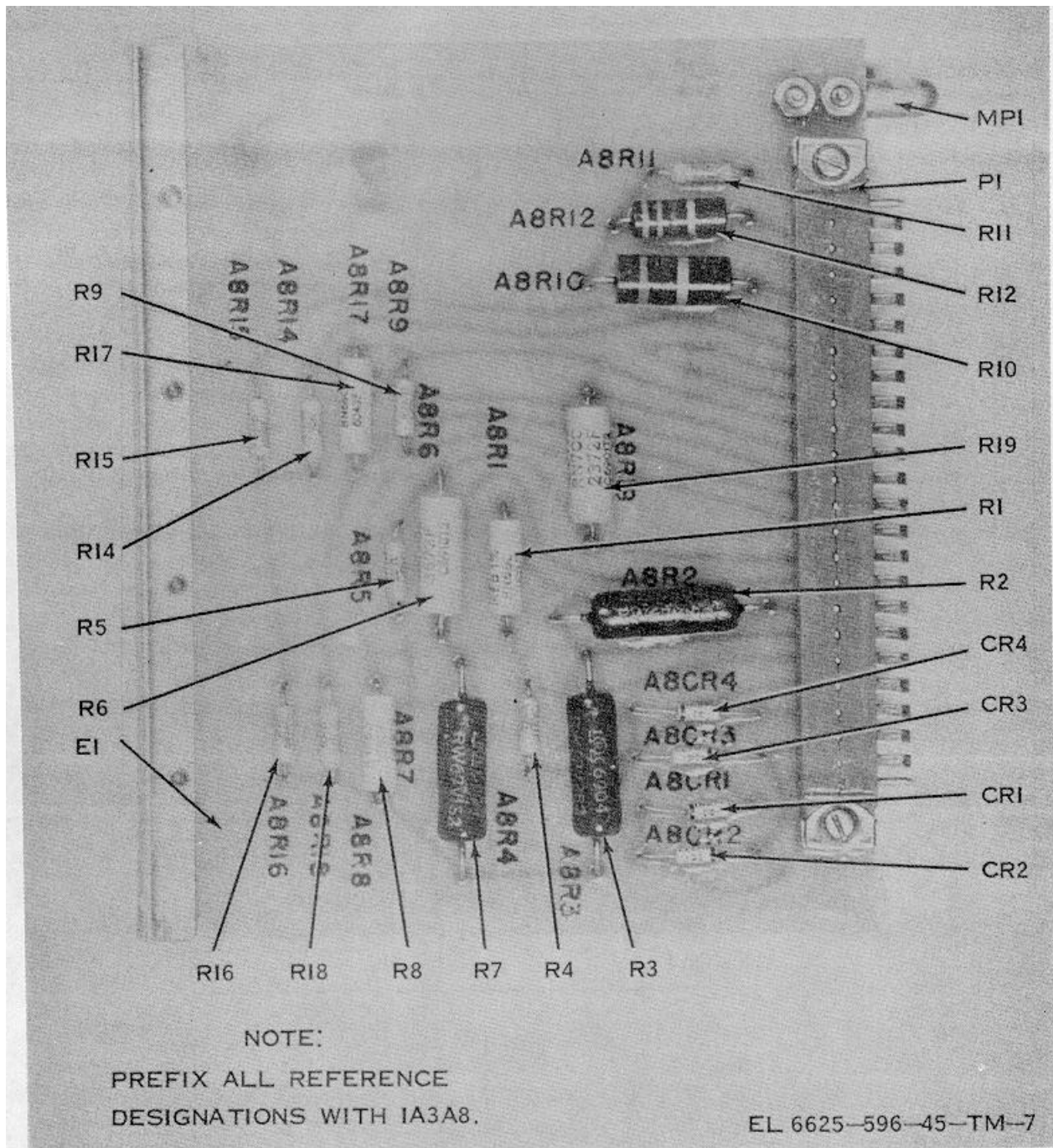

Figure 3-14. Ring generator assembly, 1A3A8, parts location.

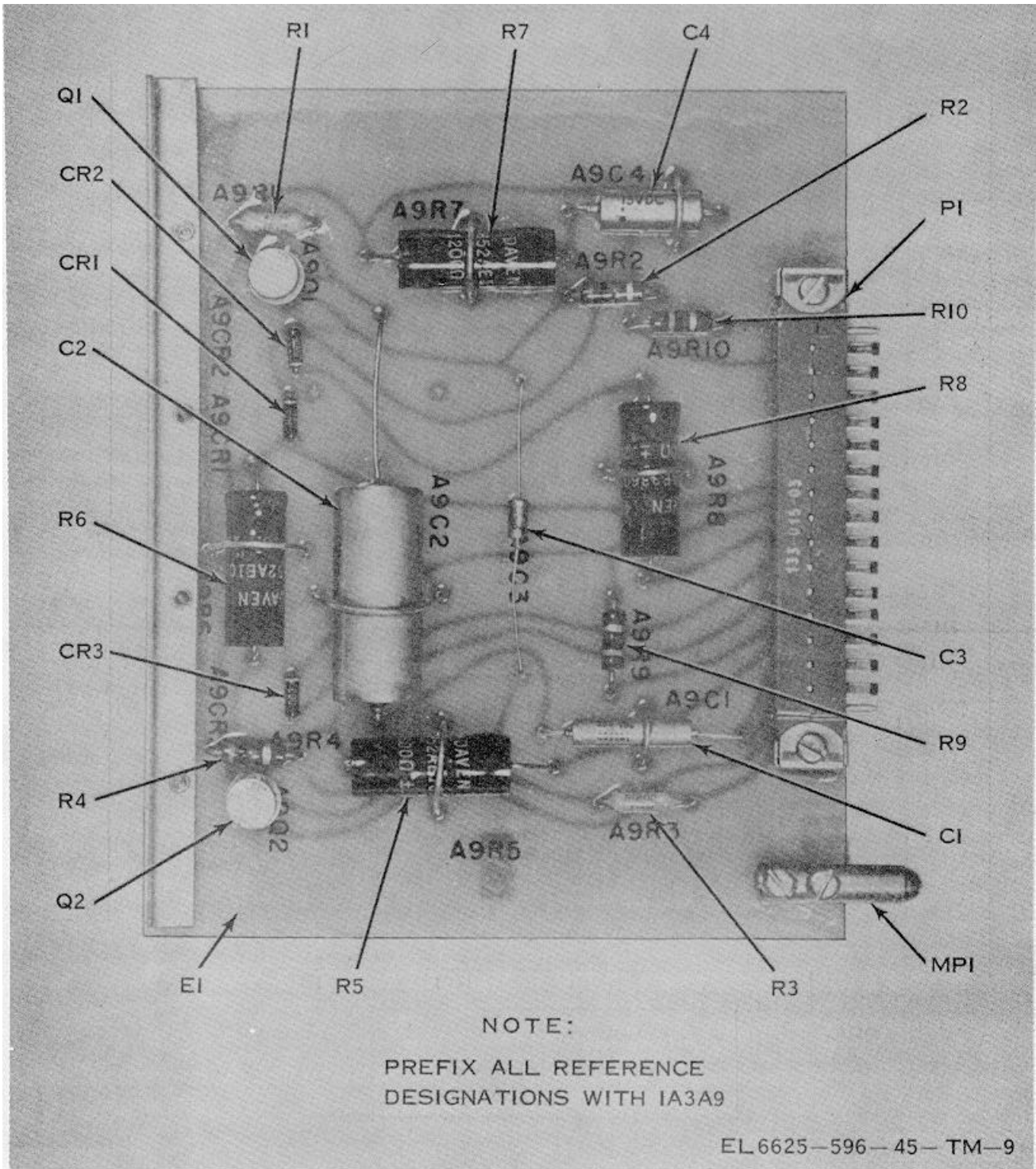

Figure 3-15. Dial percent break assembly 1A3A9, parts location.

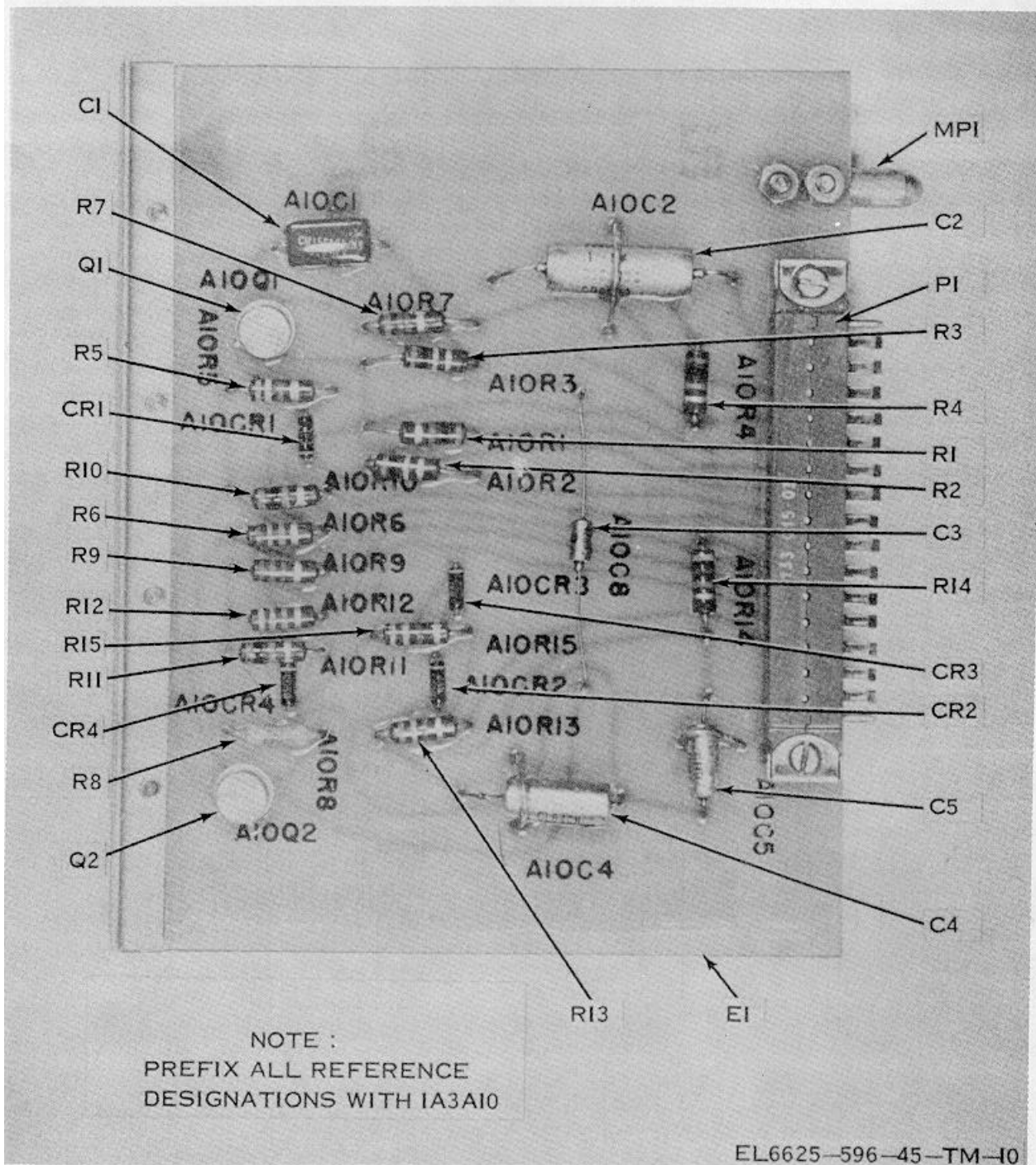
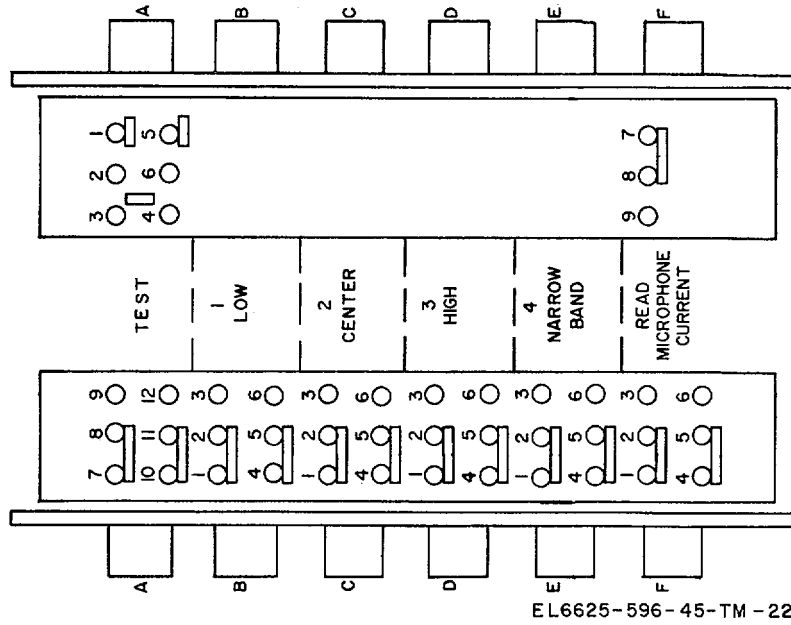

Figure 3-16. Dial speed assembly 1AA010, parts location.



EL6625-596-45-TM -22

Figure 3-17. Switch 1A14S5, TERMINL LOCATION

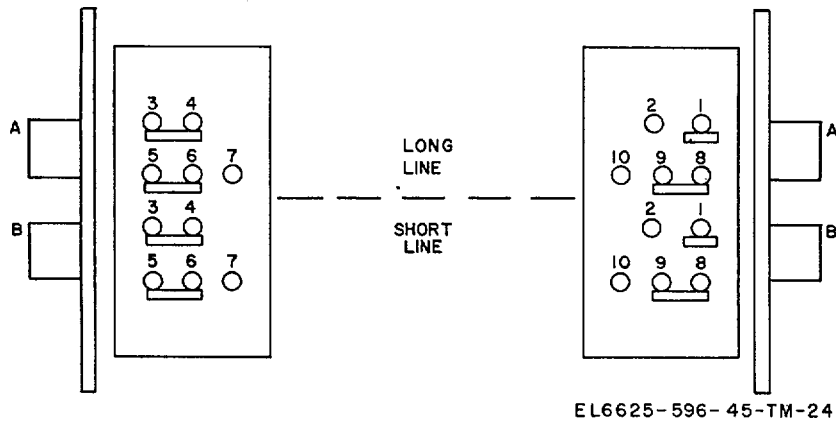

Figure 3-18. Switch 1A4S7, terminal location.

b. *Troubleshooting Chart*

<i>Action and indication</i>	<i>Possible cause</i>	<i>Correction</i>
Turn power switch 1A4S8 on. POWER ON lamp 1A4DS2 does not light	Fuses 1A4F2, 1A4F3 (230-volt input) or 1A4F4, 1A4F5 (115-volt input) are blown.	Replace fuses. Check power switch to see that correct line voltage is selected. Check power cable and connections. If fuses blow again, remove 1A3A5 and 1A3A6. a. Check for shorts to ground from 1A3J5-H, -D, and -F. If a short is found, check 1A3CR2, remove each printed circuit board until the short is eliminated. If no short is located, replace 1A3A5. b. Check for shorts to ground from 1A3J6-B, -A, -H, and -C. If a short is found, check 1A3CR1, remove each printed circuit board until the short is eliminated. If no short is found, replace 1A3A6.
If signal is heard in loudspeaker but meter does not read.	No signal at 1A3J8-U ----- No signal at 1A3J8-V----- No signal at 1A3J8-A----- No signal at 1A3J8-B----- No signal at 1A4M-1-----	Check continuity between 1A3J8-U, 1A3R11-1, and 1A3J4-B. Replace 1A38. Check continuity between 1A3J8-V, 1A4S6A-5, and 1A3J8-A. Replace 1A3AS. Check continuity between 1A3J8-B, 1A4S6A-8, 1A4S6A-7, 1A4S6M-7, 1A4S6L-5, 1A4S5F-5, and 1A4M1-1.
Signal to 1A4M1-1 but no reading on meter.	Open circuit-----	Check continuity between 1A4M1-2, 1A4S5F-2, 1A4S5F-1, 1A4S6L-1, 1A4S6M-4, and 1A3J8-C. With 1A3A8 inserted, measure resistance from 1A3J8-C to ground. If more than 30 ohms, replace 1A3A8.
METER ADJ button 1A4S6S depressed. Meter does not deflect when METER SENSITIVITY control 1A4R14 is rotated.	No signal at 1A3J8-N----- No signal at 1A3J8-M----- No signal at 1A3J2-S----- No signal at 1A3J2-C----- No signal at 1A4M11-----	Check continuity between 1A3S6A-2 and 1A3J8-N. Replace 1A3A8. Check continuity between 1A3J8-M, 1A4S5E-4, 1A4S5D-4, 1A4S5C-4, 1A4S5B-4, 1A4S7B-5, 1A4S7A-5, 1A4S7A-6, and 1A3J2-B. Check continuity between: a. 1A3J2-J and 1A3R14-1. b. 1A3J2-L and 1A3R14-2. c. 1A3R14-3 and ground. If present, replace 1A3A2. Check continuity between: a. 1A3J2-C and 1A3R16-1. b. 1A3R16-2, 1A4S6N-10, 1A4S6E-7, 1A4S6D-7, 1A4S6C-7, 1A4S6B-5, and 1A4S6A-7.
Signal at 1A4M1-1, no deflection of meter. Inverter 1A3A11 does not operate when R1NGER button 1A4S6C, 1A4S6D, or 1A4S6E, or INSULATION RESISTANCE button 1A4S6N is depressed.	Open circuit----- Fuse 1A3F1 blown----- No 100 volts dc at 1A3A11-1-----	Check continuity between 1A4S6S-2, 1A4S6S-1, 1A3J2-F, and 1A3J8-C. Replace 1A3F1 (FIG. 3-3). If 100 volts dc at 1A3A11-1, replace 1A3A11. If 100 volts dc not at 1A3A11-1, check for presence at 1A3J5-D. If not at 1A3J5-D, replace 1ASA5. If 100 volts dc at 1A3J5-D, check continuity between: a. 1A3J5-D and 1A3XFI-1. b. 1A3A11-1 and 1A3XFI-2.

<i>Action and indication</i>	<i>Possible cause</i>	<i>Correction</i>
Inverter operates but meter does not deflect when RINGER button is depressed	No signal at 1A3J8-H-----	Check continuity between 1A3A11-3 and 1A3J8-H.
	No signal at 1A3J8-F-----	Replace 1A3A8.
	No signal at 1A3J8-Y-----	Check continuity (1A4S6C depressed) between 1A3J8-Y, 1A4S6C-2, 1A4S6C-1, and 1A3J8-F.
	No signal at 1A3J8-W-----	Check continuity (1A4S6E depressed) between 1A3J8-W, 1A4S6E-2, 1A4S6E-1, and 1A3J8-F.
	No signal at 1A3J8-X-----	Replace 1A3A8.
	No signal at 1A3J8-E-----	Replace 1A3A8.
	No signal at 1A3J8-A-----	Check continuity between 1A3J8-E and 1A3J8-A.
	No signal at 1A3J8-T-----	Check continuity between: a. 1A3J8-7, 1A4S6N-7, and 1A3R13-3. b. 1A3R13-2 and 1A3J8-T.
	No signal at 1A3J8-S-----	Replace 1A3A8.
	No signal at 1A3J8-Z-----	Check continuity between 1A3J8-S, 1A4S5A-11, 1A4S5A-10, and 1A3J8-Z.
<i>Note.</i> Greatly reduced amplitude ring tests operate normally but meter does not indicate on insulation resistance tests	No signal 1A3J8-X-----	Replace 1A3A8.
	No signal at 1A3J8-A-----	Check continuity between 1A3J8-X, 1A4S6N-4, 1A4S6N-5, and 1A3J8-A.
EARPHONES button 1A4S6G depressed, no reading on meter. Test microphone placed on test loudspeaker; LEVEL and VALUE controls 1A4AT1 through 1A4AT4 as follows: A-10, B-8, C-6, D-10.	Open switch-----	Check continuity between 1A4S6F-7, 1A4S6F-6, and 1A3J2-F.
TEST CONDITION switch 1A4S9 to COUPLER.		
NOISE GENERATOR switch 1A4S3 to DRIVER.		
Press LOW button 1A4S5A. No reading on meter	No signal at 1A4S9-3-----	Check continuity between: a. 1A2A14J12-1 and 1A2A14R2-1. b. 1A2A14R2-2 and 1A4S9-3. Check 1A2A14C1 for short to ground (TEST CONDITION switch 1A4S9 at ART REC momentarily). Replace microphone 1A2A4A4 or inject signal from oscillator at 1A2A14J12.
	No signal at 1A4T2-10-----	Press READ MIC CURRENT button 1A4S5F and check for short from 1A4T2-2 to ground. Check for short 1A4T2-10 to ground. If no short, replace 1A4T2.
	No signal at 1A4AT1-1-----	Check continuity between 1A4AT1-1 and 1A4T2-10.
	No signal at 1A4AT1-3-----	Replace 1A4AT1.
	No signal at 1A4AT2-1-----	Check continuity between 1A4AT2-1 and 1A4AT1-3.
	No signal at 1A4AT2-3-----	Replace 1A4AT2.
	No signal at 1A3J1-L-----	Check continuity between 1AJ11-L and 1A4AT2-3.
	No signal at 1A3J1-A-----	Check for 10 volts dc at 1A3JI-C; replace 1A3A1.
	No signal at 1A3FL-1-----	Check continuity between 1A3JI-A, 1A4S6H-1, 1A4S5B-3, and 1A4FLI-1.
	No signal at 1A3FL1-3-----	Replace 1A3FL1.
	No signal at 1A3J1-P-----	Check continuity between 1A3FL1-3, 1A4S6H-5, and 1A3JI-P.
	No signal at 1A3J1-R-----	Replace 1A3A1.
	No signal at 1A3J2-S-----	Check continuity between 1A3A1-R and 1A4S5B-5.
SOUND POWER TELEPHONE button 1A4S6H depressed; no deflection of meter.	Open switch-----	Check 1A4S6H.

<i>Action and indication</i>	<i>Possible cause</i>	<i>Correction</i>
MICROPHONES OTHER TYPES button 1A4S6J depressed; no deflection of meter.	Open circuit-----	Check continuity between 1A3J2-F, 1A4S6J-1, 1A4S6J-2, and 1A3J8-C.
MICROPHONES-CARBON button 1A4S6K depressed; no deflection of meter.	Open circuit-----	Check continuity between 1A3J2-F, 1A4S6K-1, 1A4S6K-2, and 1A3J8-C.
Connect 220-ohm resistor from MICROPHONES CARBON terminal 1A4E1 to LO terminal 1A4E2. Depress READ MIC CURRENT button 1A4S5F and slowly turn MICROPHONE CURRENT control 1A4R1. Meter 1A4M1 should read from 0 to 60.		
No reading on 1A4M1-----	Open circuit-----	Check continuity between: a. 1A3J5-H, 1A3LI-1, 1A3LI-2, and 1A4R2-2. b. 1A4R2-1, 1A4S.6K-4, and 1A4A1-1. c. 1A4A1-2 and 1A4E1. d. 1A4E2 and 1A3J8-L. e. 1A3J8-R and 1A4S5F-5.
Depress DIAL BREAK button 1A4S6L.	No 24 volts de at 1A3J9-D-----	Check voltage; check continuity between 1A3J9-D, 1A4S6L-7, and 1A3J5-H.
No meter deflection when DIAL BREAK control 1A4E18 is roated	Open circuit to 1A4M1	Check continuity between: a. 1A3J9-J and 1A4S6L-5. b. 1A4S6L-2 and 1A4R18-2. c. 1A4R18-1 and 1A3J1-D. d. 1A4R18-3 and 1A3J10-H. Replace 1A3A9.
Depress DIAL SPEED button 1A4S6L; no meter deflection when DIAL SPEED control 1A4R17 is rotated.	No simulated dial pulse at 1A3J9-C-----	Check continuity between; a. 1A3J9-B and 1A3R15-2. b. 1A3R15-1 and ground.
	No simulated dial pulse at 1A3J10-J ---	Check continuity between 1A3J9-C and 1A3J10-J.
	No simulated dial pulse at 1A3J10-L-----	Replace 1A3A10.
	No simulated dial pulse at 1A3J10-K-----	Check continuity between 1A3J10-K, 1A4S5A-8, 1A4S5A-7, and 1A3J10-L.
	No monostable multivibrator pulse	Replace 1A3A10. Check continuity below. at 1A3J10-P.
	No monostable multivibrator pulse at 1A3R17-1.	Check continuity between: a. 1A3R17-1 and 1A3J10-P. b. 1A3R17-2 and 1A3J10-B. c. 1A3R17-3 and 1A3J10-D.
	Open circuit to 1A4M1-----	Check continuity between: a. 1A3J10-F, 1A4S6M-9, and 1A4S6M-8. b. 1A4S6M-5 and ground.
High reading of meter; needle cannot be brought below midscale by turning DIAL SPEED control 1A4R17.	Multivibrator of 1A3A9 out of calibration. Readjust 1A3R15 (para 4-6). 1A3A10 defective.	The monostable multivibrator of 1A3A10 must have an on time of .050 second more and a period of exactly 0.10 second. If the waveform at 1A3J10-P has a period less than .10 second with 1A3R15 set as described in paragraph 4-6, replace 1A3A10.

3-4. Voltage Measurements

a. *General.* Voltage measurements at receptacles 1A3J1 through J10 (FIG. 3-3 in to which assemblies 1A3A1 through A10 (FIG. 3-2) plug are listed in the charts in b through k below. Voltage measurements at the terminals of power transformer 1A3T1 (FIG. 3-3) are listed in the chart in 1 below. Measure the voltages with the test equipment specified, and with test microphone 1A2A4A4 directly over test loudspeaker 1A2A2.

(1) Unless otherwise specified, controls are set as follows:

<i>Control</i>	<i>Position</i>
NOISE GEN ADJ button 1A4S6A-----	Depressed
TEST CONDITION switch 1A4S9-----	COUPLER
NOISE GENERATOR switch 1A4S3-----	DRIVER
VALUE controls C and D 1A4AT3 and 1A4AT4.	0
LEVEL controls A and B 1A4AT1 and 1A4AT2.	0
MICROPHONE LOAD switch 1A4S1-----	OFF
RECEIVER LOAD switch 1A4S2-----	OFF
BATTERY switch 1A4S4-----	CB

(2) Adjust the CALIBRATE controls listed in the Control column of the chart below for a

midscale reading on meter 1A4M1 when the corresponding button listed in the *Button* column is pressed.

<i>Control</i>	<i>Button</i>
NOISE GENERATOR 1A4R12.	GEN ADJ 1A4S6A.
METER SENSITIVITY 1A4R14.	ADJ 1A4S6S.
INSULATION RESIS- TANCE 1A4R13.	INSULATION RESIS- TANCE 1A4S6N.
DIAL SPEED 1A4R17	DIAL SPEED 1A4S6M.
DIAL BREAK 1A4R18	DIAL BREAK 1A4S6L.

b. Preamplifier Assembly 1A3A1.

<i>1A3J1-</i>	<i>Volts</i>	<i>Measured with</i>	<i>Switch depressed</i>
A-----	-12 de	TS-352B/U	Any
C-----	-15 rms	Vtvm	Any
L-----	.004 rms	Vtvm	Any

c Meter Amplifier Assembly 1A3A2.

<i>1A3J2</i>	<i>Volts</i>	<i>Measured with</i>	<i>Switch depressed</i>
B-----	-30 de	TS-352	Any
C-----	1.2 rms	Vtvm	1A4S6S
C-----	2.5 rms	Vtvm	1A4S5C
D-----	2.0 rms	Vtvm	1A4S6S
D-----	.10.3 rms	Vtvm	1A4S5C
S-----	.016 rms	Vtvm	1A4S6S
S-----	.016 rms	Vtvm	1A4S5C

d. Noise Generator Assembly 1A3A3.

<i>1A3J3</i>	<i>Volts</i>	<i>Measured with</i>	<i>Switch depressed</i>
P-----	- 12 de	TS-352B/U	Any
F-----	0045 rms	Vtvm	Any

e. Power Amplifier Assembly 1A3A4.

<i>1A3J4</i>	<i>Volts</i>	<i>Measured with</i>	<i>Switch depressed</i>
B-----	2.5 rms	Vtvm	Any
D-----	0	Vtvm	Any
F-----	8.0 rms	Vtvm	Any
H-----	8.0 rms	Vtvm	Any
J-----	8.0 rms	Vtvm	Any
K-----	8.0 rms	Vtvm	Any
S-----	.0003 rms	Vtvm	Any
M-----	-30 de	TS-352B/U	Any

f. Positive Power Supply Assembly 1A3A5.

<i>1A2J5-</i>	<i>Volts</i>	<i>Measured with</i>	<i>Switch depressed</i>
B-----	150 vac (to 1A3J5- E)	TS-352B/U	Any
D-----	+100 de	TS-352B/U	Any
E-----	150 ac (to 1A3J5- B)	TS-352B/U	Any
F-----	+10 de	TS-352B/U	Any
H-----	+24 de	TS-352B/U	Any
P-----	75 ac (to 1A3J5- S)	TS-352B/U	Any
S-----	75 ac (to 1A3J5-P)	TS-352B/U	Any

g. Negative Power Supply Assembly 1A3A6.

<i>1A3J6-</i>	<i>Volts</i>	<i>Measured with</i>	<i>Switch depressed</i>
A-----	-30 de	TS-352B/U	Any
B-----	-30 de	TS-352B/U	Any
C-----	-12 de	TS-352B/U	Any
H-----	-12 de	TS-3r2B/U	Any
M-----	76 ac (to 1A3J6-S)	TS-352B/U	Any
S-----	76 ac (to 1A3J6-M)	TS-352B/U	Any

h. Transmission Efficiency Assembly 1A3A7.

<i>1A3J7</i>	<i>Volts</i>	<i>Measured with</i>	<i>Switch depressed</i>
B-----	.017 rms	Vtvm	1A4S6P
C-----	.32 rms	Vtvm	1A4S6P
M-----	10 rms	Vtvm	1A4S6F
M-----	.012 rms	Vtvm	1A4S6R
S-----	10 rms	Vtvm	1A4S6F
S-----	.013 rms	Vtvm	1A4S6R
T-----	-- .012 rms	Vtvm	Vtvm 1A4S6F
T-----	10 rms	Vtvm	1A4S6R
W-----	2.5 rms	Vtvm	NOISE GENERA- TOR switch 1A4S3 to LOAD. 1A4S6R 1A4S6R
Y-----	.25 rms	Vtvm	1A4S6R
Z-----	2.8 rms	Vtvm	1A4S6R

i. Ring Generator Assembly 1A3A8.

<i>1A3J8</i>	<i>Volts</i>	<i>Measured with</i>	<i>Switch depressed</i>
A-----	.32 rms	Vtvm	1A4S6A
B-----	.16 de	Vtvm	1A4S6A
C-----	.16 de	Vtvm	1A4S6A
E-----	.7 pp	Oscilloscope	1A4S6N
F-----	---- 100 pp	Oscilloscope	Oscilloscope
H-----	100 pp	Oscilloscope	1A4S6N
L-----	0 to 1 de Rotate	TS-352B/U	1A4S6K, 1A4S5F MICRO- PHONE CUR- RENT control 1A4R1. 1A4S6S 1A4S6S 1A4S6N 1A4S6N 1A4S6A 1A4S6A 1A4S6E 1A4SEN 1A4S6C 1A4S6N
M-----	.0015 rms	Vtvm	1A4S6S
N-----	2.5 rms	Vtvm	1A4S6S
S-----	80 pp	Oscilloscope	1A4S6N
T-----	100 pp	Oscilloscope	1A4S6N
U-----	2.5 rms	Vtvm	1A4S6A
V-----	0.3 rms	Vtvm	1A4S6A
W-----	.6 pp	Oscilloscope	1A4S6E
X-----	.6 Dp	Oscilloscope	1A4SEN
Y-----	100 pp	Oscilloscope	1A4S6C
Z-----	80 pp	Oscilloscope	1A4S6N

j. Dial Percent Break Assembly 1A3A9.

<i>1A3J9</i>	<i>Volts</i>	<i>Measured with</i>	<i>Switch depressed</i>
A-----	+10 de	TS-352B/U	Any
B-----	2-pp saw-	Oscilloscope	Any

	1A3J9	Volts	Measured with	Switch depressed
C-----		14 pp	Oscilloscope	Any
D-----		+14.2 dc	TS-352B/U	1A4S6L
F-----		+14.0 de	TS-352B/U	1A4S6L
J-----		+4.6 de	TS-352B/U	1A4S6L
L-----		+8.0 dc	TS-352B/U	1A4S6L

k. Dial Speed Assembly 1A8A10.

	1A3J10	Volts	Measured with	Switch depressed
B-----		2.5 pp	Oscilloscope	Any
D-----		2.0 pp	Oscilloscope	Any
F-----		.017 rms	Vtvm	Any
		20-Hertz sine wave	Oscilloscope	Any
H-----		+6 de	TS-352B/U	Any
J-----		14 pp	Oscilloscope	Any
K-----		8 pp	Oscilloscope	Any
L-----		8 pp	Oscilloscope	Any
M-----		+10 dc	TS-352B/U	Any
N-----		+9 de	TS-352B/U	1A4S5A
P-----		4.5 pp	Oscilloscope	Any

i. Power Transformer 1AST1. Measure the following 60-Hertz ac line voltages with the TS-352B/U.

1A3T1 terminals		
From	To	Volts (ac)
1	3	230
1	2	115
11	18	76
8	10	75
5	7	150
14	15	7.2

3-5. Resistance Measurements of Plug-in Assemblies

a. General. Resistance measurements from pin to-pin of plug-in assemblies 1A3A1 through 1A3A10 are listed in the charts in b through k below. The measurements are made with the assembly removed from the TS-716/U. The readings are accurate to +-20 percent, because of the wide variation in resistance of transistors and diodes mounted on the assemblies.

CAUTION

Always measure resistance in the direction shown in the charts; that is, with the positive lead of the multimeter on the *from* pin and the negative lead on the *to* pin. Reversing polarity may damage the tantalum capacitors mounted on the assemblies.

b. Preamplifier Assembly 1ASA1.

1A3A1P1 terminals		
From	To	Resistance (ohm)
A	C	
K	C	4.5K
L	K	

1AA1P1 terminals		
From	To	Resistance (ohms)
P	S	700

P	R	600
S	R	700

c. Meter Amplifier Assembly 1A8A2.

1A3A1P1 terminals		
From	To	Resistance (ohms)
A	C	7.5K
A	F	7.6K
B	P	600
C	F	10
C	P	
D	A	5 meg
D	C	7K
F	A	5 meg
F	C	7K
F	D	20
J	B	20K
J	A	15K
P	A	0
S	P	

d. Noise Generator Assembly 1A3A3.

1A3A4P1 terminals		
From	To	Resistance (ohms)
C	P	2K
F	P	

e. Power Amplifier Assembly 1A3A4.

1A3A4P1 terminal		
From	To	Resistance (ohms)
B	D	2
H	J	50
H	K	20
J	E	200
R	E	200
R	K	200
R	M	1.6K

f. Positive Power Supply Assembly 1A3A5.

1A3A5P1 terminals		
From	To	Resistance (ohms)
B	D	800
D	B	
D	C	10K
D	E	
F	K	950
H	F	200
H	K	1.2K
P	H	1.75 K
P	S	
S	H	2.25K
S	P	
E	D	2.25K

g. Negative Power Supply Assembly 1A3A6.

1A3A6P1 terminals		
From	To	Resistance (ohms)
A	B	0
A	M	190
A	S	190
A	H	4K

1A3A6P1 terminals

From	To	Resistance (ohms)
C	A	2.2K
C	E	40
E	C	
H	E	35
H	M	25K
M	S	
S	M	
H	S	7.5K

h. Transmission Efficiency Assembly 1ASA7.

1ASA7P1 terminals

From	To	Resistance (ohms)
A	B	600
A	C	160
A	H	5K
A	L	600
A	P	650
D	H	
K	C	1.1K
S	M	1K
T	M	200
V	W	45
V	R	
Y	V	60
Z	Y	

i. Ring Generator Test Assembly 1A3A8.

1A3A8P1 terminals

From	To	Resistance (ohms)
A	B	650
A	C	8 meg
B	A	5 meg
C	A	650
C	B	1.150
D	E	330
D	F	2.7K
F	H	1K
L	M	600
L	R	9K
J	L	1.4K
N	M	600K
P	K	24K
S	J	375K
U	V	50K
V	L	50K
W	X	1.9K
Y	X	5K
Z	X	1 meg

j. Dial Percent Break Assembly 1A3A9.

1A3A9P1 terminal

From	To	Resistance (ohms)
A	B	36K
C	S	
D	C	
D	F	1 600
D	J	50K
E	K	2.7K
H	K	2.2K

L	S	3.8K
P	R	0
R	S	2,700

k. Dial Speed Assembly 1A3A10.

1A3A10P1 terminals

From	To	Resistance (ohms)
B	C	20K
B	D	20K
B	E	20K
B	F	20K
C	E	100
D	C	560
H	E	2.4K
J	L	100K
N	K	125K
N	R	
M	N	100K
M	L	1.2 meg

3-6. Dc Resistance of Transformers and Coils

a. The dc resistance data is provided as an aid to troubleshooting. When using the data, observe the following:

(1) Before making resistance measurements of the windings, determine that faulty operation is very likely due to a faulty transformer or coil. To do this, follow the procedures given in the troubleshooting chart (para 3-3).

(2) Do not use the resistance measurements as the sole basis for discarding a transformer or coil as defective. Bear in mind that due to rather broad winding tolerances during manufacture, resistances may vary from one transformer or coil to another. The chart values are typical average values.

(3) The normal resistance of replacement transformers may differ greatly from the values given in the chart.

(4) Check power transformer 1A3T1 in accordance with the voltage chart given in paragraph 3-41.

b. The following chart lists the dc resistance of the transformer windings and coils in the TS-716/U.

Transformer or coil	Terminals	Resistance (ohms)
1A3T1 (FIG. 3-3 -----)	1-2	6.7
	1-3	25.6
	5-6	54
	6-7	55
	8-9	7.4
	9-10	7.6
	11-12	7.9
	12-13	7.9
	14-15	1.0
	1A4T2 (FIG. 3-5)-----	1-2
2-3		.9
3-4		.7
4-5		3.3
5-6		2.1
6-7		18.0

<i>Transformer or coil</i>	<i>Terminal</i>	<i>Resistance (ohms)</i>	<i>Transformer or oil</i>	<i>Terminal</i>	<i>Resistance (ohms)</i>
	7-8	2,030.0		4-5	5.4
	9-10	29.1		6-7	6.5
1A3L1 (FIG. 3-3)-----	1-2	67.3	1A3A4T3 (FIG. 3-10) -----	1-2	37.0
1A3A4T1 (FIG. 3-10)-----	1-2	4.4		2-3	37.0
	3-5	72.3		4-5	3.2
1A3A4T2 (FIG. 3-10)-----	1-2	161 nom	1A3A7T1 (FIG. 3-13) -----	1-2	93.6
	23	256 nom		3-4	124.0

**CHAPTER 4
REPAIRS AND ALIGNMENT**

4-1. General Parts Replacement Techniques

a. Most parts of the TS-716/U are readily accessible and are replaced using conventional repair practices. Use figures 3-1 through 3-6 as a guide for locating parts and making repairs.

b. Use a pencil-type iron with a 25-watt maximum capacity for transistorized circuits. When a high temperature iron is to be used for installing diodes and transistors, grasp the lead between the soldering iron and the component with a pair of long-nose pliers. This protects the component from excessive heat. If the iron must be used with ac, use an isolating transformer between the iron and the line. Check the iron for shorts to the tip before it is used. See TB SIG-222.

c. If printed boards are to be repaired, note the following precautions:

- (1) Locate and identify the parts (FIG. 3-7 through 3-16).
- (2) Remove the conformal coating

material from the part to be replaced with a hot soldering iron.

(3) When diodes or transistors are to be installed, use approximately the same length and dress of leads as used originally.

(4) If the copper foil peels off the bottom of the board during repair, discard the board.

d. Repair or replacement of the following units requires recalibration of portions of the test set circuitry.

(1) If test loudspeaker 1A2A2 is replaced, adjust 1A3R11 (para 4-3).

(2) If microphone 1A2A4A4 or capacitor 1A2A14C1 is replaced, adjust 1A2A14R2 (, para 4-5).

(3) If meter amplifier 1A3A2 is repaired or replaced, adjust 1A3R16 (para 4-4).

(4) If dial break board 1A3A9 is repaired or replaced, adjust 1A3R15 (para 4-6).

4-2. Test Equipment Required for Alignment

<i>Test equipment</i>	<i>Technical manual</i>	<i>Common name</i>
Signal Generator TS-382/U-----	TM 11-6625-261-12-----	Audio oscillator.
Voltmeter ME-30/U-----	TM 11-6625-320-12-----	Vacuum tube voltmeter (vtvm).
Oscilloscope AN/USM-140-----	TM 11-6625-535-15-----	Oscilloscope.
Calibrated microphone flat within -2 dB, 200 to 6, 000 Hz Capable of measuring sound pressure of 28 dynes/cm ² and General Radio Sound Level Meter Model 1551C or equivalent.		Sound level meter.

4-3. Acoustic Output Adjustment 1A3R11 (FIG. 3-3)

a. Start the test set as described in TM 11-6625-596-12.

b. Depress NOISE GEN ADJ button 1A136A and vary NOISE GENERATOR control 1A4R12 until meter 1A4M1 reads at the red CAL mark.

c. Holding the standard microphone at the screen of test loudspeaker 1A2A2, adjust 1A3R11 until the ground pressure at the screen of the test loudspeaker is 28 ynes/cm² (103 dB + 1 dB -0 dB).

d. If necessary, readjust NOISE GENERATOR control 1A4R12 to bring the needle of meter 1A4M1 back to the red CAL mark.

e. Repeat c and d above as many times as necessary until the sound pressure at the screen of the test loudspeaker is 28 dynes/cm² when the needle of meter 1A4M1 rests on the red CAL mark.

4-4. Meter Amplifier Gain Adjustment 1A3R16 (FIG. 3-3)

a. Start the test set as described i-n TM 11-6625-596-12.

b. Depress NOISE GEN ADJ button 1A4S6A, and rotate NOISE GENERATOR control 1A4R12 until needle of meter 1A4M1 is at the red CAL line.

c. Connect the vtvm between 1A3J2-D and ground.

d. Depress METER ADJ button 1A4S6S and adjust METER SENSITIVITY CALIBRATE control 1A4R14 on the front panel until an output voltage of 2.0 volts (+0.05 volt) root mean square (rms) is obtained.

e. Adjust 1A3R16 until the panel meter reads at the red CAL line on meter 1A4M1. Lock the potentiometer.

**4-5. Microphone Equalization Adjustments
1A2A14R1 and R2**

(FIG. 3-6)

After the adjustments given in paragraphs 4-3 and 4-4 have been performed, place test micro-phon 1A2A4A4 directly over test loudspeaker 1A2A2 touching the screen and proceed as follows:

a. Set the front panel controls as follows:

<i>Control</i>	<i>Position</i>
EARPHONES button 1A4S6G-----	Depressed
TEST CONDITION switch 1A4S9-----	COUPLER
NOISE GENERATOR switch 1A4S3-----	DRIVER
LEVEL control A 1A4AT1-----	10
LEVEL control B 1A4AT2-----	8
VALUE control C 1A4AT3-----	6
VALUE control D 1A4AT4-----	9

b. Press LOW button 1A4S5B and adjust 1A2A14R2 until meter 1A4M1 reads midscale.

c. Press HIGH button 1A4S5D and adjust 1A2A14R1 until meter 1A4M1 reads midscale.

d. Press CENTER button 1A4S5C, meter 1A4M1 should read midscale. Adjust 1A2A14R1 and R2 such that the reading on meter 1A4M1 is as near midscale as possible when the LOW, CENTER and HIGH buttons are pressed.

4-6. Dial Speed Adjustment 1A3R15
(FIG. 3-3)

a. Connect the oscilloscope to 1A3J9-C.

b. Adjust 1A3R15 until the period between the pulses (time from start to one pulse to start of next pulse) is exactly 0.050 second.

c. Connect the oscilloscope to 1A3J10-P. The period (time from start of one pulse to start of following pulse) should be exactly 0.100 second. The pulse width should be .05 to .06 second, the exact width is not important.

d. Press DIAL SPEED button 1A4S6M. Adjust DIAL SPEED CALIBRATE control 1A4R17 until meter 1A4M1 reads midscale. If the reading on 1A4M1 cannot be set to midscale, see trouble-shooting chart (para 3-3b).

**4-7. Noise Generator Load/Driver Adjustment
1A3R9**

(FIG. 3-3)

a. Depress NOISE GEN ADJ button 1A4S6A and adjust NOISE GENERATOR CALIBRATE control 1A4R12 to obtain a red CAL line reading on meter 1A4M1.

b. Set TEST CONDITION switch 1A4S9 to COUPLER, NOISE GENERATOR switch 1A4S3 to LOAD, and recalibrate noise generator (a above).

c. Turn NOISE GENERATOR switch 1A4S3 to DRIVER. The needle of meter 1A4M1 should stay at the red CAL line.

d. Adjust 1A3R9 until the needle of meter 1A4M1 stays at the red CAL line when NOISE GENERATOR switch 1A4S3 is switched from LOAD to DRIVER.

CHAPTER 5 SHIPMENT AND LIMITED STORAGE

5-1. Disassembly of Equipment

Disassemble Telephone Test Set TS-716/U and prepare it for movement as follows:

- a. Place the coupler in the position shown in figure 3-1.
- b. Replace the cover of the spares compartment and lock the two , quick-disconnect fasteners.
- c. Secure the powerline plug in the receptacle

in the side of the spares compartment.

d. Place the cover on the case, secure all latches.

5-2. Repackaging for Shipment or Limited Storage

The exact procedure for repackaging depends on the material available and the conditions under which the equipment is to be shipped or stored. The travel case that housed the Telephone Test Set TS-716/U is usually sufficient to protect the equipment for limited storage. (See SB 38100.)

**CHAPTER 6
DEPOT OVERHAUL STANDARDS**

6-1. Applicability of Depot Overhaul Standards

The tests outlined in this chapter are designed to measure the performance capability of a repaired equipment. Equipment that is to be returned to stock should meet the standards given in these tests.

6-2. Applicable References

a. Repair standards. Applicable procedures of the depot performing these tests and the general standards for repaired electronic equipment given in TB SIG 355-1, TB SIG 355-2, and TB SIG 355-3 form a part of the requirements for testing this equipment.

b. Technical Publications. The following technical publications are applicable to this equipment:

<i>Title</i>	<i>Publication</i>
Operator's and Organizational	TM 11-6625-596-12

<i>Test equipment</i>	<i>Technical manual</i>	<i>Common name</i>
General Radio Sound Level Meter Model 1551C or equivalent.	-----	Sound level meter.
Voltmeter ME-30/U-----	TM 11-6625-320-12----	Vacuum tube voltmeter (vtvm).
Transformer, Variable Power TF-523/U-----	-----	TM 11-5950-212-15-----Variac.
Signal Generator TS-382/U-----	TM 11-6625-261-12----	Audio oscillator.
Resistor, Decade ZM-16A/U-----	TM 11-5102-----	Decade resistance box.
Spectrum Analyzer TS-723A/U-----	TM 11-5097-----	Distortion analyzer.
Hewlett-Packard Model 400-D or equivalent (two required).	-----	Vacuum tube voltmeter (vtvm).
Microphone reciprocity calibrator -----	-----	-----Calibrator.
General Radio Type 1559-A.		
Tool Equipment TE-28.		
Tool Kit, Electronic Equipment TK-105/G.		
Tool Kit, Electronic Equipment TK-100/G.		
Telephone Set TA-236/FT (calibrated).		
Western Electric Type 555W or equivalent -----	-----	Driver.
Western Electric Type 640AA or equivalent -----	-----	Microphone.

6-4. General Test Requirements

Most of the test will be started with the controls positioned as listed:

<i>Control</i>	<i>Position</i>
Power switch 1A4S8-----	OFF.
NOISE GEN ADJ button----- 1A4S6A.	Depressed.

Maintenance Manual, Telephone Test Set TS-716/U.
 GS and Depot Maintenance Manual, Telephone Test Set TS-716/U. TM 11-6625-596-45
 Telephone Test Set TS-716/U, Norms and Testing Procedures. TB 11-6625-596-12/1

c. Modification Work Orders. Perform all modification work orders applicable to this equipment before making the tests specified. DA Pam 310-7 lists all available MWO's.

6-3. Test Equipment Facilities Required for Depot Testing

The following items are required for depot testing.

<i>Control</i>	<i>Position</i>
NOISE GENERATOR CALIBRATE control 1A4R12.	Fully counterclockwise.
METER SENSITIVITY CALIBRATE control 1A4R14.	Fully counterclockwise.
INSULATION RESISTANCE CALIBRATE control 1A4R13.	Fully counterclockwise.

<i>Control</i>	<i>Position</i>
DIAL SPEED CALIBRATE control 1A4R17.	Fully counterclockwise.
DIAL BREAK CALIBRATE control 1A4R18.	Fully counterclockwise
NOISE GENERATOR switch 1A4S3.	DRIVER.
TEST CONDITION switch 1A4S9.	COUPLER.
MICROPHONE LOAD switch 1A4S1.	OFF.
RECEIVER LOAD switch 1A4S2.	OFF.
MICROPHONE CURRENT control 1A4R1.	OFF.
LEVEL A and B controls 1A4AT1 and 1A4AT2.	Any position.
VALUE C and C controls 1A4AT3 and 1A4AT4.	Any position.

NOTE

Changes in these position as required for each individual test will be specified in the test sequence. Leave all controls and switches in the position of the previous test unless otherwise specified.

6-5. Sound Source Supply Test

- a. Connect equipment as shown in figure 6-1.
- b. Turn power switch 1A4S8 to appropriate on position (115v or 230v), turn NOISE GENERATOR CALIBRATE control 1A4R12 until the needle of meter 1A4M1 is at the CAL line.
- c. Read the level on the sound-level meter. The reading shall be 103 dB minimum corresponding to 28 microbars of sound pressure and shall not exceed 104 dB.

Figure 6-1. Sound source supply test setup.

6-6. Driver Impedance Test

- a. Connect the equipment as shown in figure 6-2.
- b. Set the audio oscillator at a frequency of 1, 000 Hertz and 1.0 volts rms.
- c. Adjust the decade resistance box until the

resistance reading on the vtvm at SW position #1 is exactly equal to the reading at SW position #2.

- d. The reading of the resistance obtained in c above shall be 25 ohms +-10 percent.

6-7. Driver Distortion Test

- a. Connect the equipment as shown in figure 6-3.
- b. Adjust the audio oscillator output voltage to 0.96 volt rms at 300 Hertz as measured on the vtvm. Maintain this voltage throughout the test.
- c. Data shall be taken in 100-Hertz increments from 300 Hertz to 1, 000 Hertz, and in 250-Hertz increments from 1, 000 Hertz to 5, 100 Hertz.

- d. The total harmonic distortion of the unit over the frequency range cited in c above shall not exceed 5 percent.

6-8. Coupler-Microphone Distortion Test

- a. Connect the equipment as shown in figure 6-3.
- b. Set LEVEL and VALUE controls 1A4AT1 through 1A4AT4 to 0, TEST CONDITION switch 1A4S9 to COUPLER, and NOISE GENERATOR switch 1A4S3 to LOAD.
- c. Terminate the microphone output in 7 ohms.
- d. Turn NOISE GENERATOR CALIBRATE control 1A4R12 fully counterclockwise.
- e. Adjust the audio oscillator output gain sufficient to drive the distortion analyzer.
- f. Data shall be taken in 100-Hertz increments from 300 Hertz to 1, 000 Hertz, and in 500-Hertz increments from 1, 000 Hertz to 5, 100 Hertz.
- g. The data obtained in f above shall not exceed 5-percent distortion over the cited frequency range.

NOTE

The coupler-microphone and driver distortion tests may be conducted simultaneously. The combined resultant total distortion shall not exceed 5 percent.

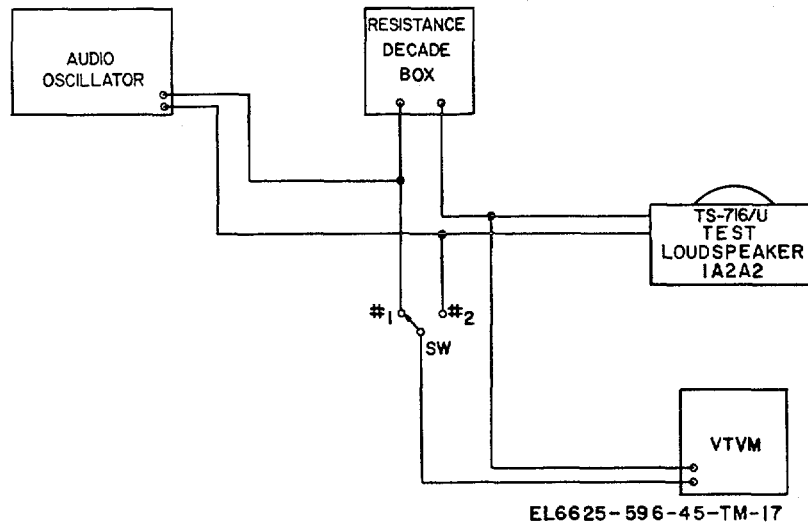

Figure 6-2. Driver impedance test setup.

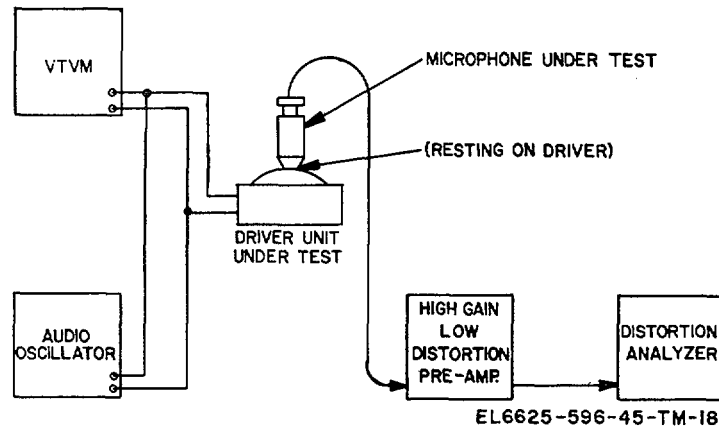

Figure 6-3. Coupler/driver unit distortion test setup.

6-9. Microphone Preampifier Frequency Response and Gain Test

a. Set the TS-716/U front panel controls as specified in paragraph 6-4 except for LEVEL and VALUE controls 1A4T1 through 1A4AT4, which must be set at 0.

b. Set TEST CONDITION switch 1A4S9 to ART REC, and MICROPHONE LOAD switch 1A4S1 to 1000, Depress SOUND POWER TELE-PHONE button 1A4S6H.

c. Connect the output of the audio oscillator to MICROPHONES-OTHER TYPES terminal 1A4E3 and LO terminal 1A4E2.

d. Set oscillator frequency to 1, 000 Hertz.

e. Connect the vtm to terminals 1A3J1-L and 1A3J1-K (ground), and adjust the oscillator output to produce a reading of 300 microvolts on the vtm. Hold this reading constant over the frequency range specified in g below.

f. Connect a vtm to terminals 1A3J1-A and 1A3J1-K.

g. Data shall be taken in 100-Hertz increments from 300 Hertz to 1, 000 Hertz, and in 250-Hertz increments from 1, 000 Hertz to 5, 100 Hertz.

h. The data obtained in g above shall show a constant gain of 60 dB (.3V) +2 over the cited frequency range.

6-10. Microphone Preamplifier Distortion Test

a. Connect the equipment as directed in paragraph 6-9, except connect the distortion analyzer to the output.

b. Measurements may be made and data taken simultaneously with those of the frequency response and gain test in paragraph 6-9.

c. Total harmonic distortion shall not exceed 2 percent over the frequency range specified in paragraph 6-9g.

6-11. Meter Amplifier Gain Test

a. Set the controls as indicated in paragraph 6-4.

b. Depress NOISE GEN ADJ button 1A4S6A and adjust NOISE GENERATOR CALIBRATE control 1A4R12 to obtain a CAL line reading on meter 1A4M1.

c. Set NOISE GENERATOR switch 1A4S3 to LOAD.

d. Set METER SENSITIVITY CALIBRATE control 1A4R14 fully clockwise.

e. Measure the input voltage (rms) between 1A3J2-S and 1A3J2-P (ground).

f. Measure the output voltage (rms) between 1A3J2-D and 1A3J2-P (ground).

g. The minimum gain shall be 62 dB.

6-12. Meter Scale Test

a. Connect the vtm leads to 1A3J2-D and 1A3J2-P (ground).

b. Adjust NOISE GENERATOR CALIBRATE control 1A4R12 to obtain a CAL line reading on meter 1A4M1.

c. Adjust METER SENSITIVITY CALIBRATE

control 1A4R14 to obtain a CAL line reading on meter 1A4M1 and note the reading on the vtm.

d. Turn METER SENSITIVITY CALIBRATE control 1A4R14 counterclockwise to obtain a reading of 30 on meter 1A4M1. This action shall produce a change of -6 dB +0.5 in the reading on the vtm.

e. Adjusting 1A4R14 to obtain a reading of 40 on 1A4M1 produces a change of -3 dB *0.5 in the reading on the vtm. Adjusting 1A4R14 so that the needle of 1A4M1 rests on the left-hand edge of the green area produces a change of -1.5 dB +0.5 in the reading on the vtm.

f. Adjusting 1A4R14 to obtain a reading of 70 on 1A4M1 produces a change of +5 dB +.5 in the reading on the vtm.

g. Adjusting 1A4R14 to obtain a reading of 60 on 1A4M1 produces a change of +3 dB +0.5 in the reading on the vtm.

h. Adjusting 1A4R14 so that the needle of 1A4M1 rests on the right-hand edge of the green area produces a change of +1.5 dB +0.5 in the reading on the vtm.

6-13. Circuit Tests Requirements

a. *General.* Set front panel controls as specified in paragraph 6-4 with the following exceptions: LEVEL A control 1A4AT1 set to 10, LEVEL B control 1A4AT2 to 8, VALUE C control 1A4AT3 to 6, VALUE D control 1A4AT4 to 9, and NOISE GENERATOR switch 1A4S3 to LOAD.

b. *Positioning Microphone.* Position the coupler microphone directly over and touching the screen of the driver unit.

c. *Preliminary Adjustments.* Turn power switch 1A4S8 to on and perform the following:

- (1) Depress NOISE GEN ADJ button 1A4SA.
- (2) Adjust NOISE GENERATOR CALIBRATE control 1A4R12 for a CAL line reading on 1A4M1.
- (3) Depress METER ADJ button 1A4S6.
- (4) Adjust METER SENSITIVITY CALIBRATE control 1A4R12 for a CAL line reading on 1A4M1.

d. *Varistor Test.*

- (1) Depress VARISTOR button 1A4S6F.
- (2) Meter 1A4M1 shall read on green scale.

e. *Earphones Test.*

- (1) Depress EARPHONES button 1A4S6G.
- (2) Meter 1A4M1 shall read on green scale.

f. Dynamic Microphone Test.
 (1) Depress MICROPHONES OTHER TYPES button 1A4S6J.
 (2) Meter 1A4M4 shall read on green scale.

g. Carbon Microphone Test.
 (1) Depress MICROPHONES CARBON button 1A4S6K.
 (2) Meter 1A4M1 shall read on green scale.

h. Telephone Efficiency-Send Test.
 (1) Depress TELEPHONE EFFICIENCY-SEND button 1A4S6R.
 (2) Meter 1A4M1 shall read on green scale.

i. Telephone Efficiency-Receive Test.
 (1) Depress TELEPHONE EFFICIENCY-RECEIVE button 1A4S6P.
 (2) Meter 1A4M1 shall read on green scale.

j. Noise Generator Test.
 (1) Set NOISE GENERATOR switch 1A4S3 to DRIVER.
 (2) Meter 1A4M1 shall read on green scale and the driver unit shall be audible.

k. Sound Power Telephone Test.
 (1) Depress SOUND POWER TELEPHONE button 1A4S6H.
 (2) Meter 1A4M1 shall read on green scale.
 (3) Press 1 LOW button 1A4S5B, meter 1A4M1 shall read approximately 80.
 (4) Remove microphone from speaker and cover with hand.
 (5) Press 1 LOW button 1A4S5B, meter 1A4M1 shall read 20 or lower.

i. Filter Test.
 (1) Depress EARPHONES button 1A4S6G.
 (2) Sequentially press 1 LOW, 2 CENTER, and 3 HIGH buttons 1A4S5B, C, and D.
 (3) Meter 1A4M1 shall read on green scale as each button is depressed.
 (4) Depress 4 NARROW BAND button 1A4S5E.
 (5) Meter 1A4M1 shall read between 40 and 50.

6-14. Insulation Resistance Test

a. Connect a decade resistance box to TEL

LINE L1 and L2 terminals on the TS-716/U front panel.

b. Depress INSULATION RESISTANCE button 1A4S6N.

c. Adjust INSULATION RESISTANCE CALIBRATE control 1A4R13 for a CAL line reading on 1A4M1.

d. Press TEST button 1A4S5A. Meter 1A4M1 shall read less than 50 for values of resistance above 1 megohm, and greater than 50 for values of resistance less than 1 megohm.

6-15. Continuity Test

a. Connect a resistance decade unit to CONTINUITY TEST LEADS terminals 1A4E14 and 1A4E15 on the TS-716 U front panel.

b. For resistance values less than 9 ohms, the buzzer shall sound and CONTINUITY TEST lamp DS1 shall light.

c. For resistance values greater than 11 ohms, the buzzer shall not function.

d. For resistance values greater than 20 ohms, the lamp shall not light.

6-16. Hand Generator Test

- a. Connect equipment as shown in figure 6-4.
- b. Set range selector switch on the hp vtm to 100 volts.
- c. Set variac to zero.
- d. Depress HAND GENERATOR button 1A4S6B. Meter 1A4M1 shall read 0.
- e. Adjust the variac for a CAL line reading on 1A4M1 and note the reading on the vtm. Vtm shall read approximately 50 volts.
- f. Disconnect the variac.

6-17. Ringer Test

a. Connect the vtm to TEL LINE L1 and L2 terminals.

b. Depress RINGER 2400 button 1A4S6C switch. The buzz of the 20-Hertz inverter shall be audible.

c. Meter 1A4M1 shall read greater than 30 and the vtm shall read greater than 50 volts.

d. Repeat b and c above, pressing RINGER 5300 button 1A4S6D and 12000 RINGER button 1A4S6E

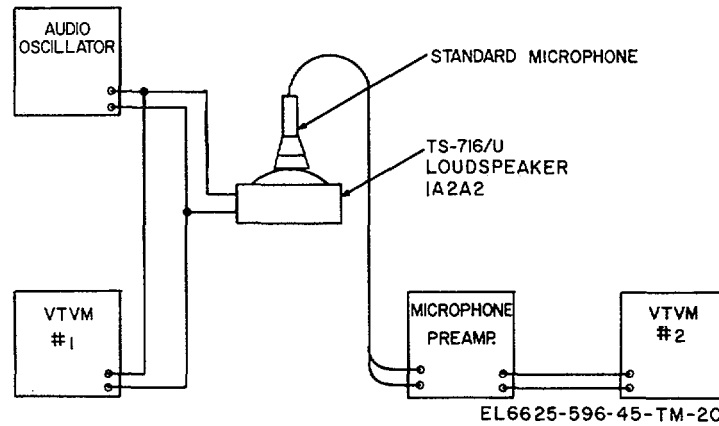

Figure 6-4. Hand generator test setup.

6-18. Dial Speed Test

- a. Set NOISE GENERATOR switch 1A4S3 to LOAD.
- b. Connect Telephone Set TA-236/FT lines L1 and L2 to the corresponding terminals on the TS-716/U front panel.
- c. Depress DIAL SPEED button 1A4S6M.
- d. Adjust DIAL SPEED CALIBRATE control 1A4R17 for a CAL line reading on meter 1A4M1.
- e. Press TEST button 1A4S5A and, with the free hand, dial 0 (operator). Meter 1A4M1 shall read in the green area.

6-19. Dial Percent Break Test

- a. With Telephone Set TA-236/FT connected as in paragraph 6-18b, depress DIAL BREAK button 1A4S6L.
- b. Adjust DIAL BREAK CALIBRATE control 1A4R18 for a CAL line reading on meter 1A4M1.
- c. Press TEST button 1A4S5A and, with the free hand, dial 0 (operator). Meter 1A4M1 shall read in the green area.

6-20. Driver Frequency Response Test

a. *Test Equipment.* The test equipment used for the response test shall meet the following requirements:

- (1) *Calibrating microphone.* A Western

Electric Co. 640AA condenser microphone, or equal, shall be used for measuring sound pressure. It shall be calibrated by the reciprocity method in accordance with A. S. A. Standard Z24.4 "Pressure Calibration of Laboratory Standard Pressure Microphones."

(2) *Audio oscillator.* The audio oscillator shall have a frequency range of at least 100 to 10,000 Hertz, shall have a high degree of stability in both output voltage and frequency, and shall have a Waveform distortion of less than 2 percent.

(3) *Vacuum-tube voltmeter.* The vacuum-tube voltmeters used must have flat frequency response (+ dB) from at least 100 to 10,000 Hertz and must be capable of measuring voltage from 0.001 rms to 100 volts or more.

(4) *Microphone preamplifier.* The microphone preamplifier shall have a flat response (+1 dB) over a frequency range of at least 100 to 10,000 Hertz, shall have a high degree of stability, and shall have distortion of less than 2 percent.

b. Connect the equipment as shown in figure 6-5.

c. Adjust the oscillator output voltage at each test frequency to read 0.96 volt rms as measured by the vtvm.

d. Data shall be taken in 100-Hertz increments from 300 Hertz to 1,000 Hertz, and in 250-Hertz increments from 1,000 Hertz to 5,100 Hertz.

e. The data obtained in d above must fall within the limits of +3 dB on a rising slope of 1-dB-per-octave zero reference centered at 1,000 Hertz. The output of the driver unit at 1,000 Hertz shall not

be less than 90 dB above a reference level of 0.0002 microbar, when 10 milliwatts rms power is applied to the driver terminals.

f. Measurements should be performed in a relatively free sound field.

6-21. Coupler Microphone Frequency Response Test

a. *Test Equipment.* The test equipment used for the response test shall meet the following requirements.

(1) *Calibrated driver unit.* Western Electric Company, Type No. 555W, or equal, previously calibrated by means of a condenser microphone such as Western Electric Company 640AA, or equal (calibrated by "Reciprocity Method" in accordance with A. S. A. Standard Z24.4-1949 "Pressure Calibration of Laboratory Standard Pressure Microphones").

(2) *Audio oscillator.* The audio oscillator shall have a frequency range of at least 100 to 10,000 Hertz, shall have a high degree of stability in both output voltage and frequency, and shall have a waveform distortion of less than 2 percent.

(3) *Vacuum-tube voltmeter.* The vacuum-tube voltmeters used must have flat frequency response

(+1 dB) from at least 100 to 10,000 Hertz and must be capable of measuring voltage from 0.001 rms to 100 volts or more.

b. Connect the equipment as shown in figure 6-6.

c. Position the coupler microphone so that it is located 1/8 inch directly in front of and parallel to the calibrated driver.

d. Connect a noninductive load resistance of 7.0 ohms across the microphone output.

e. Output power of the driver unit shall not be less than 28 microbars at the screen of the driver unit. Minimum power output of the microphone shall be -50 dBm at 1,000 Hertz, equivalent to 0.27 millivolt across a 7.0-ohm load.

f. Data shall be taken in 100-Hertz increments from 300 Hertz to 1,000 Hertz, and in 250-Hertz increments from 1,000 Hertz to 5,100 Hertz.

g. The data obtained in f above must fall within the limits of +3 dB centered at 1,000-Hertz reference level.

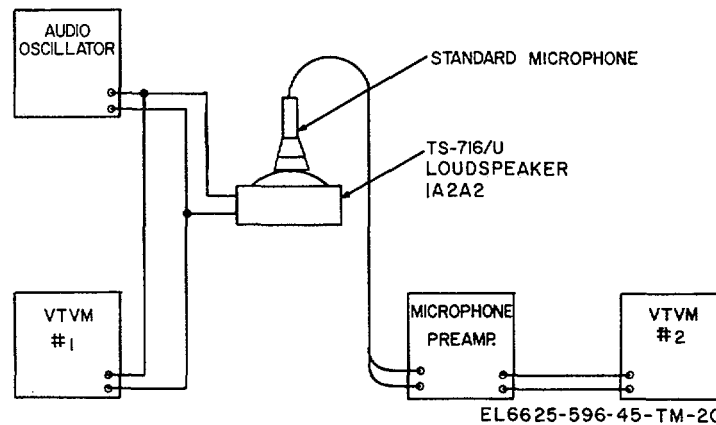

Figure 6-5. Driver frequency response test setup.

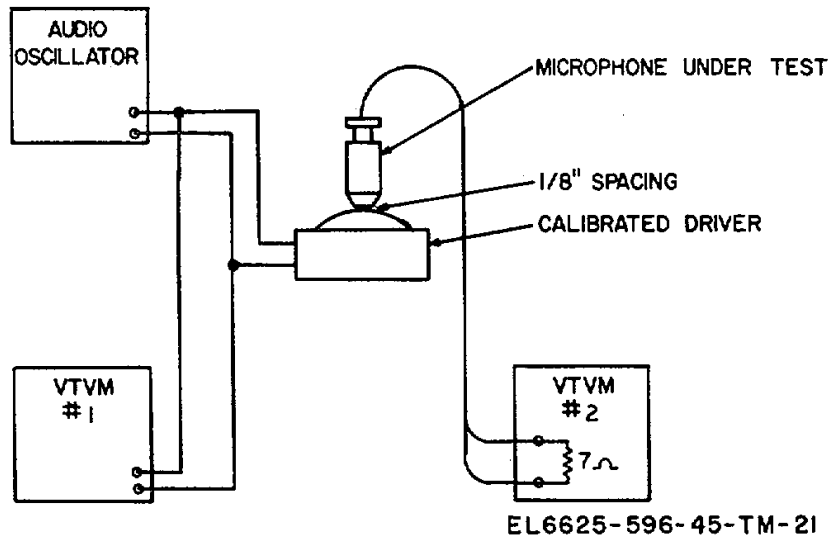
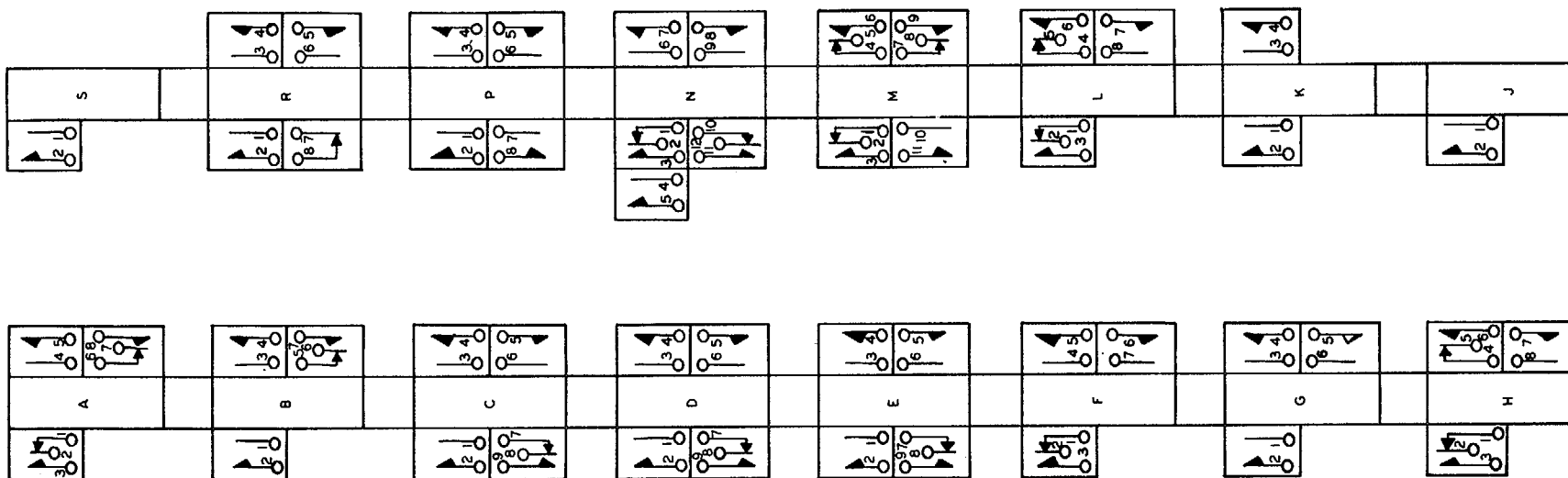

Figure 6-6. Microphone frequency response test set-up.

Figure 6-7 Color code marking for MILSTD resistors, inductors, and capacitors.
(Located in back of manual.)

Figure 6-8 Telephone Test Set TS-716/U, simplified block diagram.
(Located in back of manual.)



NOTES:

1. VIEWS ARE FROM KNOB END OF SWITCH.
2. ALL 16 BUTTONS ARE INTERLOCKED. WHEN ONE BUTTON IS DEPRESSED, ALL OTHER BUTTONS ARE RELEASED. NO TWO BUTTONS CAN BE DEPRESSED SIMULTANEOUSLY.
3. SWITCH IS SHOWN WITH NO BUTTONS DEPRESSED.
4. EACH STATION IS STACKED AS SHOWN.

EL6625-596-45-TM-23

Figure 6-9. Switch 1A4S6, Terminal Location

Figure 6-10 Telephone Test Set TS-716/U,
complete schematic diagram.
(Located in back of manual.)

APPENDIX A REFERENCES

The following applicable publications are available to DS and depot maintenance personnel for Telephone Test Set TS-716/U.

- | | |
|---------------------|---|
| DA Pam 310-4 | Index of Technical Manuals, Technical Bulletins, Supply Manuals (types 7, 8 and 9), Supply Bulletins, and Lubrication Orders. |
| DA Pam 310-7 | Index of Modification Work Orders. |
| SB 38-100 | Preservation, Packaging, and Packing and Marking Materials, Supplies and Equipment used by the Army. |
| TB 746-10 | Field Instructions for Painting and Preserving Electronics Command Equipment. |
| TB 11-6625-596-12/1 | Telephone Test Set TS-716/U, Norms and Testing Procedures. |
| TB SIG 222 | Solder and Soldering. |
| TB SIG 355-1 | Depot Inspection Standard for Repaired Signal Equipment. |
| TB SIG 355-2 | Depot Inspection Standard for Refinishing Repaired Signal Equipment. |
| TB SIG 355-3 | Depot Inspection Standard for Moisture and Fungus Resistant Treatment. |
| TM 11-5097 | Spectrum Analyzers TS-723A/U, TS-723B/U, TS-723C/U, and TS-723D/U. |
| TM 11-5102 | Resistors, Decade ZM-16/U, ZM-16A/U, and ZM-16B/U. |
| TM 11-5950-212-15 | Operator's, Organizational, DS, GS, and Depot Maintenance Manual Including Repair Parts and Special Tool Lists: Transformers, Variable Power TF-523/U. |
| TM 11-6625-203-12 | Operator's and Organizational Maintenance: Multimeter AN/URM-105, including Multimeter ME-77/U. |
| TM 11-6625-261-12 | Operator's and Organizational Maintenance Manual: Audio Oscillators TS-382A/U, TS-382B/U, TS-382D/U, TS-82E/U and TS-382F/U. TM 11-6625-320-12 Operator's and Organizational Maintenance Manual: Voltmeter, Meter ME-30A/U and Voltmeters, Electronic ME-30B/U, ME-30C/U, and ME-30E/U. |
| TM 11-6625-366-15 | Organizational, DS, GS, and Depot Maintenance Manual: Multimeter TS-352B/U. |
| TM 11-6625-535-15 | Operator's, Organizational, DS, GS, and Depot Maintenance Manual: Oscilloscope AN/USM-140A. |
| TM 11-6625-539-15-2 | Operator's, Organizational, DS, GS, and Depot Maintenance Manual Including Repair Parts and Special Tool Lists: Test Set, Transistor TS-1836B/U. |
| TM 11-6625-596-12 | Operator's Organizational Maintenance Manual, Including Repair Parts and Special Tool List: Telephone Test Set TS-716/U. |

APPENDIX B

GENERAL SUPPORT AND DEPOT MAINTENANCE REPAIR PARTS
AND SPECIAL TOOLS LIST

Section I. INTRODUCTION

B-1 Scope

This appendix lists repair parts required for the performance of general support and depot maintenance of the TS-716/U. No parts authorized for storage at direct support maintenance.

NOTE

No special tools, test, and support equipment are required.

B-2 General

This repair parts list is divided into the following sections:

a. Repair Parts-Section II. A list of repair parts authorized for the performance of maintenance at the general support and depot level.

b. Index-Federal Stock Number or Reference Number Cross-Reference to Figure and Item Number or Reference Designation-Section III. A list of Federal stock numbers in ascending numerical sequence (section III.1) followed by a list of reference numbers appearing in ascending alpha-numeric sequence (section III.2) cross-referenced to the illustration figure number and reference designation.

c. Index-Reference Designation Cross-Reference to Page Number-Section IV. A list of reference designations cross-referenced to page number.

B-3 Explanation of Columns

The following provides an explanation of columns in the tabular lists:

a. Source, Maintenance, and Recoverability Codes (SMR), Column 1:

(1) Source Code, indicates the selection status and source for the listed item. Source codes used are:

<i>Code</i>	<i>Explanation</i>
Code P	-Repair parts which are stocked in or supplied

- Code P2 -Repair parts which are procured and stocked for insurance purposes because the combat or military essentiality of the end item dictates that a minimum quantity be available in the supply system.
- Code P9 -Assigned to items which are NSA design controlled: unique repair parts, special tools, test, measuring and diagnostic equipment which are stocked and supplied by the Army COMSEC logistic system, and which are not subject to the provisions of AR 380-41. Code P10-Assigned to items which are NSA design controlled: special tools, test, measuring and diagnostic equipment, for COMSEC support, which are accountable under the provisions of AR 380-41, and which are stocked and supplied by the Army COMSEC logistic system.
- Code M -Repair parts which are not procured or stocked, but are to be manufactured in indicated maintenance levels.
- Code A -Assemblies which are not procured or stocked as such, but are made up of two or more units. Such component units carry individual stock numbers and descriptions, are procured and stocked separately and can be assembled to form the required assembly at indicated maintenance categories.
- Code X -Parts and assemblies which are not procured or stocked and the mortality of which normally is below that of the applicable end item or component. The failure of such part or assembly should result in retirement of the end item from the supply system. Code X1 -Repair parts which are not procured or stocked. The requirements for such items will be filled by use of the next higher assembly or component.
- Code X2 -Repair parts which are not stocked. The indicated maintenance category requiring such repair parts will attempt to obtain same

<i>Code</i>	<i>Explanation</i>
	through cannibalization. Where such repair parts are not obtainable through cannibalization, requirements will be requisitioned, with accompanying justification, through normal supply channels.
Code C	-Repair part authorized for local procurement. Where such repair parts are not obtainable from local procurement, requirements will be requisitioned through normal supply channels accompanied by a supporting statement of non-availability from local procurement
Code G	-Major assemblies that are procured with PEMA funds for initial issue only as ex-change assemblies at DSU and GSU level. These assemblies will not be stocked above DS and GS level or returned to depot supply level.

(2) Maintenance code, indicates the lowest category of maintenance authorized to install the listed item. The maintenance level codes are:

<i>Codes</i>	<i>Explanation</i>
0-----	Organizational Maintenance
F-----	Direct Support Maintenance
H-----	General Support Maintenance
D-----	Depot Maintenance

(3) Recoverability code, indicates whether unserviceable items should be returned for recovery or salvage. Items not coded are expendable. Recoverability codes are:

<i>Code</i>	<i>Explanation</i>
Code R	-Repair parts and assemblies that are economically reparable at DSU and GSU activities and normally are furnished by supply on an exchange basis.
Code S	-Repair parts and assemblies which are economically reparable at DSU and GSU activities and which normally are furnished by supply on an exchange basis. When items are determined by a GSU to be uneconomically repairable, they will be evacuated to a depot for evaluation and analysis before final dis-position.
Code T	-High dollar value recoverable repair parts which are subject to special handling and are issued on an exchange basis, such repair parts normally are repaired or overhauled at depot maintenance activities.
Code U	-Repair parts specifically selected for salvage by reclamation units because of precious metal content, critical materials, or high dollar value, reusable casings or castings.

b. *Federal Stock Number, Column 2.* This

column indicates the Federal Stock Number assigned to the item and will be used for requisitioning purposes.

c. *Description Column 3.* This column indicates the Federal item name and any additional description of the item required. A part number or other reference number is followed by the applicable five-digit Federal supply code for manufacturers in parentheses.

d. *Unit of Measure (U./M), Column 4.* A 2 character alphabetic abbreviation indicating the amount of quantity of the item upon which the allowances are based, e.g., ft., ea., pr., etc.

e. *Quantity Incorporated in Unit, Column 5.* This column indicates the quantity of the item used in the TS-716/U. Subsequent appearances of the same item in the same assembly are indicated by the letters "R" "F."

f. *30 day, DS/GS Maintenance Allowances, Column 6 and 7.*

NOTE

Allowances in GS column are for GS maintenance only.

(1) The allowance columns are divided into three subcolumns. Indicated in each subcolumn, opposite the first appearance of each item, is the total quantity of items authorized for the number of equipments supported. Subsequent appearances of the same item will have the letters "REF" in the applicable allowance columns. Items authorized for use as required, but not for initial stock-age, are identified with an asterisk in the allowance column.

(2) The quantitative allowances for GS levels of maintenance will represent initial stockage for a 30-day period for the number of equipments supported.

(3) Determination of the total quantity of parts required for maintenance of more than 100 of these equipments can be accomplished by converting the equipment quantity to a decimal factor by placing a decimal point before the next to last digit of the number to indicate hundredths and multiplying the decimal factor by the parts quantity authorized in the 51-100 allowance column. Example, authorized allowance for 51-100 equipments is 40; for 150 equipments multiply 40 by 1.50 or 60 parts required.

g. *1-Year Allowances Per 100 Equipments/Contingency Planning Purposes, Column 8.* This column indicates opposite the first appearance of each item the total quantity required for distribution and contingency planning purposes. The range of items indicates total quantities of all

authorized items required to provide for adequate support of 100 equipments for one year.

h. Depot Maintenance Allowance per 100 Equipments, Column 9. This column indicates opposite the first appearance of each item, the total quantity authorized for depot maintenance of 100 equipments. Subsequent appearances of the same item will have the letters "REF" in the allowance column. Items authorized for use as required but not for initial stockage are identified with an asterisk in the allowance column.

i. Illustrations.

(1) Figure number, column 10a. Indicates the figure number of the illustration in which the item is shown.

(2) Item number or reference designation, column 10b. Indicates the items reference designation used to identify the item in the illustration.

B-4. Special Information

Repair parts mortality is computed from failure rates derived from experience factors with the individual parts in a variety of equipments. Variations in the specific application and periods of use of electronics equipment, the fragility of electronic piece parts, plus intangible material and quality factors intrinsic to the manufacture of electronic parts, do not permit mortality to be based on hours of end item use. However, long periods of continuous use under adverse conditions are likely to increase repair parts mortality.

B-5. Location of Repair Parts

a. This appendix contains two cross-reference indexes (sec. III and IV) to be used to locate a repair part when either the Federal stock number, reference number (manufacturer's part number), or reference designation is known. The first column in each index is prepared in numerical or alphanumeric sequence in ascending order. Where a Federal stock number is listed refer to section III.1. Where a Federal stock number is not listed, refer to section III.2.

b. When the Federal stock number or reference number is known, follow the procedures given in (1) and (2) below.

(1) Refer to section III.1 (index of Federal stock numbers) or section III.2 (index of reference numbers) and note the applicable figure and reference designation.

(2) When the reference designation is determined, refer to the reference designation index (sec. IV). The reference designations are listed in numeric-alpha ascending order and are cross-referenced to the page number on which they appear in the repair parts list (sec. II). Refer to the page number noted in the index and locate the reference designation in the repair parts list (col. 10b). If the letters "REF" appear in the allowance column for the repair part, scrutinize columns 2 and 3 of the repair parts list until the first appearance is located.

c. When the reference designation is known, follow the procedures given in *b* (2) above.

d. When neither the FSN, reference number, nor reference designation is known, identify the part in the illustration and follow directions given in *c* above, or scrutinize column 3 of the repair parts list.

6. Federal Supply Codes for Manufacturers

<i>Code</i>	<i>Manufacturer</i>
02230-----	Electronics of Clearfield Inc.
46384-----	Penn Engineering & Mfg. Corp.
61007-----	Tubular Rivet & Stud Co.
71087-----	Boots Aircraft Nut Division Townsend Co.
73168-----	Fenwal Inc.
73734-----	Federal Screw Products Inc.
75915-----	Littelfuse Inc.
80063-----	Army Electronics Command
81349-----	Military Specifications
92194-----	Alpha Wire Corp.
96906-----	Military Standards

Section II. REPAIR PARTS FOR DIRECT SUPPORT, GENERAL SUPPORT, AND DEPOT MAINTENANCE

(1) SMR CODE	(2) FEDERAL STOCK NUMBER	(3) DESCRIPTION USABLE ON CODE REFER. NO. & MFR. CODE	(4) UNIT OF MEAS	(5) QTY INC IN UNIT	(6) 30-DAY DS MAINT ALLOWANCE			(7) 30-DAY GS MAINT ALLOWANCE			(8) 1 YR ALW PER EQUIP CNTGCTY	(9) DEPOT MAINT ALW PER 100 EQUIP	(10) ILLUSTRATIONS	
					(a)	(b)	©	(a)	(b)	©			(a)	(b)
					1-20	21-50	51-100	1-20	21-50	51-100			FIG. NO.	ITEM NO. OR REFERENCE DESIGNATION
GCS	6625-96-1433	TEST SET, TELEPHONE, TS-716/U (This item is nonexpendable)	EA	1									1-1	1
XZH		CASE, BOTTOM ASSEMBLY 003193 (02230)	EA	1									1-1	1A1
XZH		CASE, BOTTOM 101974-A (02230)	EA	1										1A1A1
XZH		CHANNEL, SPACER ASSEMBLY 001992 (02230)	EA	2										1A1A2
MD		SPACER, PLATE 00187 (02230)	EA	1										1A1A2MP1
XZH	5310-0134530	NUT, PLAIN, HEXAGON MS35649-62 (96906)	EA	5										1A1A2MP1H5
X2H	5305-543-2188	SCREW MACHINE MS5223-32 (96906)	EA	5										1A1A2MP1H10
XZH	53 10-045-4007	WASHER, LOCK MS3338-41 (96906)	EA	5										1A1A5MP1H15
XZH		ALUMINUM ALLOY CHANNEL ASSEMBLY 003042 (02230)	EA	1										1A1A2MP2
X2H	53107536089	NUT, PLAIN, PLATE T65S1032S (71087)	EA	1										1A1A2MP3
XZH		SCREW TAPPING THREAD FORMING MS24647 (96906)	EA	2										1A1A2MP3H2
MD		SPACER, PLATE 003082 (02230)	EA	1										1A1A2MP4
XZH		CHANNEL SPACER ASSEMBLY 003232 (02230)	EA	2										1A1A3
MD		SPACER, PLATE 001872 (02230)	EA	1										1A1A3MP1
XZH	5310-013-4530	NUT, PLAIN, HEXAGON MS25649-62 (96906)	EA	5										1A1A3MP1H5
XZH	5305-543-2188	SCREW MACHINE MS35223-32 (96906)	EA	5										1A1A3MP1H10
XZH	5310-45-4007	WASHER, LOCK MS35338-41 (96906)	EA	5										1A1A3MP1H15
XZH		ALUMINUM ALLOY CHANNEL ASSEMBLY 002982 (02230)	EA	1										1A1A3MP1
XZH	530-753-5089	NUT, PLAIN, PLATE T65S1032S (71087)	EA	1										1A1A3MP2
XZH		SCREW, TAPPING, THREAD FORMING MS24647 (96906)	EA	2										1A1A3MP2H2
MD		SPACER, PLATE 003082 (02230)	EA	1										1A1A3MP3
X2H		CHANNEL SPACER ASSEMBLY 001982 (02230)	EA	2										1A1A4
MD		SPACER, PLATE 001872 (02230)	EA	1										1A1A4MP1
XZH	5310-013-430	NUT, PLAIN, HEXAGON MS35649-62 (96906)	EA	5										1A1A4MP1H5
XZH	5305-543-2188	SCREW MACHINE MS35223-32 (96906)	EA	5										1A1A4MP1H10

SECTION II REPAIR PARTS FOR DIREST SUPPORT, GENERAL SUPPORT, AND DEPOT MAINTENANCE (CONTINUED)

(1) SMR CODE	(2) FEDERAL STOCK NUMBER	(3) DESCRIPTION USABLE ON CODE REFER. NO. & MFR. CODE	(4) UNIT OF MEAS	(5) QTY INC IN UNIT	(6) 30-DAY DS MAINT ALLOWANCE			(7) 30-DAY GS MAINT ALLOWANCE			(8) 1 YR ALW PER EQUIP CNTGCT	(9) DEPOT MAINT ALW PER 100 EQUIP	(10) ILLUSTRATIONS	
					(a) 1-20	(b) 21-50	© 51-100	(a) 1-20	(b) 21-50	© 51-100			(a) FIG. NO.	(b) ITEM NO. OR REFERENCE DESIGNATION
X2H	5310-045-4007	WASHER, LOCK MS35338-41 (96906)	EA	5										1A1A4MP1H15
X2H		ALUMINUM ALLOY CHANNEL ASSEMBLY 003042 (02230)	EA	1										1A1A4MP1
X2H	5310-753-5089	NUT, PLAIN, PLATE T65S1032S (71087)	EA	1										1A1A4MP2
X2H		SCREW, TAPPING, THREAD FORMING MS24647 (96906)	EA	2										1A1A4MP2H2
MD		SPACER, PLATE 001872 (02230)	EA	1										1A1A4MP3
X2H		CHANNEL SPACER ASSEMBLY 003232 (02230)	EA	REF										1A1A5
MD		SPACER, PLATE 001872 (02230)	EA	1										1A1A5MP1
X2H	5310-013-4530	NUT, PLAIN, HEXAGON MS35649-62 (96906)	EA	5										1A1A5MP1H5
X2H	5305-543-2188	SCREW MACHINE MS3223-32 (96906)	EA	5										1A1A5MP1H10
X2H	5310-045-4007	WASHER, LOCK MS35338-41 (06906)	EA	5										1A1A5MP1H15
X2H		ALUMINUM ALLOY CHANNEL ASSEMBLY 003042 (02230)	EA	1										1A1A5MP1
X2H	5310-753-5089	NUT, PLAIN, PLATE T65S1032S (71087)	EA	1										1A1A5MP2
X2H		SCREW, TAPPING, THREAD FORMING MS24647 (96906)	EA	2										1A1A5MP2H2
MD		SPACER, PLATE 003082 (02230)	EA	1										1A1A5MP3
X2H		CHANNEL SPACER ASSEMBLY 003232 (02230)	EA	REF										1A1A6
MD		SPACER, PLATE 001872 (02230)	EA	1										1A1A6MP1
X2H	5310-013-4530	NUT, PLAIN, HEXAGON MS35649-62 (96906)	EA	5										1A1A6MP1H5
X2H	5305-543-2188	SCREW MACHINE MS35223-32 (96906)	EA	3										1A1A6MP1H10
X2H	5310-045-4007	WASHER, LOCK MS35338-41 (96906)	EA	5										1A1A6MP1H15
X2H		ALUMINUM ALLOY CHANNEL ASSEMBLY 003042 (02230)	EA	1										1A1A6MP1
X2H	5310-753-5089	NUT PLAIN PLATE T65S1032S (71087)	EA	1										1A1A6MP2
X2H		SCREW, TAPPING, THREAD FORMING MS24647 (96906)	EA	2										1A1A6MP2H2
MD		SPACER, PLATE 001872 (02230)	EA	1										1A1A6MP8
X2H		CHANNEL SPACER ASSEMBLY 001992 (02230)	EA	REF										1A1A7
MD		SPACER, PLATE 0018172 (02230)	EA	1										1A1A7MP1

SECTION II REPAIR PARTS FOR DIREST SUPPORT, GENERAL SUPPORT, AND DEPOT MAINTENANCE (CONTINUED)

(1) SMR CODE	(2) FEDERAL STOCK NUMBER	(3) DESCRIPTION USABLE ON CODE REFER. NO. & MFR. CODE	(4) UNIT OF MEAS	(5) QTY INC IN UNIT	(6) 30-DAY DS MAINT ALLOWANCE			(7) 30-DAY GS MAINT ALLOWANCE			(8) 1 YR ALW PER EQUIP CNTGCTY	(9) DEPOT MAINT ALW PER 100 EQUIP	(10) ILLUSTRATIONS	
					(a)	(b)	©	(a)	(b)	©			(a)	(b)
					1-20	21-50	51-100	1-20	21-50	51-100			FIG. NO.	ITEM NO. OR REFERENCE DESIGNATION
X2H	5310-013-4530	NUT PLAIN, HEXAGON MS35649-62 (96906)	EA	5										1AA7MP1H5
X2H	5305-53-2188	SCREW MACHINE MS35223-32 (96906)	EA	5										1A17AMP1H10
X2H	5310-045-4007	WASHER LOCK MS5338-41 (96906)	EA	1										1A1A7MP1H15
X2H		ALUMINUM ALLOY CHANNEL ASSEMBLY 003042 (02230)	EA	1										1A1A7MP1
X2H	5310-753-5089	NUT, PLAIN, PLATE T65S1032S (71087)	EA	1										1A1A7MP2
X2H		SCREW, TAPPING, THREAD FORMING MS24647 (96906)	EA	2										1A1A7MP2H
MD		SPACER, PLATE 003082 (02230)	EA	1										1A1A7MP3
X2H		CASE, TOP ASSEMBLY 001764 (02230)	EA	1										1A2
X2H		CASE, TOP 001974-B (02230)	EA	1										1A2A1
X2H		CLIP, SPRING TENSION 003142 (02230)	EA	1										1A2MP1
X2H	5310-013-4530	NUT, PLAIN, HEXAGON MS35649-62 (96906)	EA	2										1A2MP1H2
X2H	5305-043-6665	SCREW MACHINE MS35225-30 (96906)	EA	2										1A2MP1H4
X2H		WASHER, FLAT MS27183-5 (96906)	EA	2										1A2MP1H6
X2H	5310-045-4007	WASHER, LOCK MS35338-41 (96906)	EA	2										1A2MP1H8
PH	5965-488-2745	LOUDSPEAKER, PERMANENT MAGNET SMD38022 (80063)	EA	1				*	*	*	5	3	3-1	1A2A2
X2H		BRACKET, ANGLE 003002 (02230)	EA	1										1A2A2MP1
X2H	5310-013-4530	NUT, PLAIN, HEXAGON MS5649-62 (96906)	EA	3										1A2A2MP1H3
X2H	5305-043-6666	SCREW MACHINE MS35225-31 (96906)	EA	3										1A2A2MP1H6
X2H		WASHER FLAT MS27183-5 (96906)	EA	3										1A2A2MP1H9
X2H	5310-045-4007	WASHER LOCK MS35338-41 (96906)	EA	3										1A2A2MP1H12
X2H		BRACKET, ANGLE 003032 (02230)	EA	1										1A2A2MP2
X2H	5310-013-4530	NUT, PLAIN, HEXAGON MS35649-62 (96906)	EA	2										1A2A2MP2H2
X2H	5305-043-6666	SCREW MACHINE MS35225-31 (96906)	EA	2										1A2A2MP2H4
X2H		WASHER, FLAT MS27183-5 (96906)	EA	2										1A2A2MP2H6
X2H	5310-045-4007	WASHER, LOCK MS35338-41 (96906)	EA	2										1A2A2MP2H8

SECTION II REPAIR PARTS FOR DIREST SUPPORT, GENERAL SUPPORT, AND DEPOT MAINTENANCE (CONTINUED)

(1) SMR CODE	(2) FEDERAL STOCK NUMBER	(3) DESCRIPTION USABLE ON CODE REFER. NO. & MFR. CODE	(4) UNIT OF MEAS	(5) QTY INC IN UNIT	(6) 30-DAY DS MAINT ALLOWANCE			(7) 30-DAY GS MAINT ALLOWANCE			(8) 1 YR ALW PER EQUIP CNTGCTY	(9) DEPOT MAINT ALW PER 100 EQUIP	(10) ILLUSTRATIONS	
					(a)	(b)	©	(a)	(b)	©			(a)	(b)
					1-20	21-50	51-100	1-20	21-50	51-100			FIG. NO.	ITEM NO. OR REFERENCE DESIGNATION
X2H	5310-761-6882	NUT, PLAIN, HEXAGON MS51967-2 (96906)	EA	2										1A2A2MP2H1
X2H	5310-543-2628	NUT, PLAIN, HEXAGON MS35690-602 (96906)	EA	2										1A2A2MP2H3
X2H	5310-809-4058	WASHER, FLAT MS27183-10 (96906)	EA	2										1A2A2MP2H6
X2H	5310-080-6004	WASHER, FLAT MS27183-14 (96906)	EA	2										1A2A2MP2H7
AHR		PANEL, TEST ELECTRICAL 002444 (02230)	EA	1									3-1	1A2A14
X2H		BRACKET, ANGLE 001792 (02230)	EA	3										1A2A14MP1
X2H	5310-013-4530	NUT, PLAIN, HEXAGON MS35649-62 (96906)	EA	2										1A2A14MP1H2
X2H	5305-043-6665	SCREW MACHINE MS35225-30 (96906)	EA	2										1A2A14MP1H4
X2H		WASHER, FLAT MS27183-5 (96906)	EA	2										1A2A14MP1H6
X2H	5310-045-4007	WASHER, LOCK MS35338-41 (96906)	EA	2										1A2A14MP1H8
X2H	5340-839-9050	FASTENER S632-2 (46384)	EA	1										1A2A14MP1H9
X2H		BRACKET, ANGLE 001792 (02230)	EA	REF										1A2A14MP2
X2H	5310-03-4530	NUT, PLAIN, HEXAGON MS35649-62 (96906)	EA	2										1A2A14MP2H2
X2H	5305-043-6665	SCREW MACHINE MS35225-30 (96906)	EA	2										1A2A14MP2H4
X2H		WASHER, FLAT MS27183-5 (96906)	EA	2										1A2A14MP2H6
X2H	5310-045-4007	WASHER, LOCK MS35338-41 (96906)	EA	2										1A2A14MP2H8
X2H	5340-839-9050	FASTENER S632-2 (46384)	EA	1										1A2A14MP2H9
X2H		BRACKET, ANGLE 001792 (02230)	EA	REF										1A2A14MP3
X2H	5310-013-4530	NUT, PLAIN, HEXAGON MS35649-62 (96906)	EA	2										1A2A14MP3H2
X2H	5305-043-6665	SCREW MACHINE MS35225-30 (96906)	EA	2										1A2A14MP3H4
X2H		WASHER, FLAT MS27183-5 (96906)	EA	2										1A2A14MP3H6
X2H	5310-045-4007	WASHER, LOCK MS35338-41 (96906)	EA	2										1A2A14MP3H8
X2H	5340-839-9050	FASTENER S632-2 (46384)	EA	1										1A2A14MP3H9
X2H		INSERT 003442 (02230)	EA	3										1A2A14MP4
X2H		INSERT 003442 (02230)	EA	REF										1A2A14MP5

SECTION II REPAIR PARTS FOR DIREST SUPPORT, GENERAL SUPPORT, AND DEPOT MAINTENANCE (CONTINUED)

(1) SMR CODE	(2) FEDERAL STOCK NUMBER	(3) DESCRIPTION USABLE ON CODE REFER. NO. & MFR. CODE	(4) UNIT OF MEAS	(5) QTY INC IN UNIT	(6) 30-DAY DS MAINT ALLOWANCE			(7) 30-DAY GS MAINT ALLOWANCE			(8) 1 YR ALW PER EQUIP CNTGCTY	(9) DEPOT MAINT ALW PER 100 EQUIP	(10) ILLUSTRATIONS	
					(a)	(b)	©	(a)	(b)	©			(a)	(b)
					1-20	21-50	51-100	1-20	21-50	51-100			FIG. NO.	ITEM NO. OR REFERENCE DESIGNATION
X2H		INSERT 003442 (02230)	EA	REF										1A2A14MP6
X2H		SCREW, CAPTIVE ASK-224-46 (02230)	EA	3										1A2A14MP6H3
X2H	5310-082-1404	WASHER, FLAT MS27183-6 (96906)	EA	3										1A2A14MP6H6
MD		BRACKET, DOUBLE ANGLE ASSEMBLY 003452 (02230)	EA	1										1A2A14MP7
X2H	5305-043-6638	SCREW MACHINE MS35225-13 (96906)	EA	4										1A2A14MP7H4
X2H	5310-951-4670	WASHER, FLAT MS27183-3 (96906)	EA	4										1A2A14MP7H8
X2H	5310-543-2410	WASHER, LOCK MS35338-40 (96906)	EA	4										1A2A4MP7H12
X2H		BUSHING, RUBBER 162444 (02230)	EA	12										1A2A14MP9
PH	5910-901-9467	CAPACITOR, FIXED ELECTROLYTIC CS13BC127K (81349)	EA	1				*	*	2	5	3	3-6	1A2A14C1
X2H		CLAMP, LOOP 14244 (02230)	EA	1										1A2A14C1MP1
X2H	5310-013-4530	NUT, PLAIN, HEXAGON MS35649-62 (96906)	EA	3										1A2A14C1MP1
X2H	5305-984-4988	SCREW MACHINE MS35206-228 (96906)	EA	1										1A2A14C1MP1H2
X2H	5310-082-1404	WASHER, FLAT MS27183-6 (96906)	EA	1										1A2A14C1MP1H3
X2H	5310-045-4007	WASHER, LOCK MS35338-41 (96906)	EA	1										1A2A14C1MP1H4
X2H		CLAMP, LOOP 14244 (02230)	EA	2										1A2A14MP11
X2H	5310-013-4530	NUT, PLAIN, HEXAGON MS35649-62 (96906)	EA	1										1A2A14MP11H1
X2H		SCREW MACHINE MS35225-28 (96906)	EA	1										1A2A14MP11H2
X2H	5310-08-1404	WASHER, FLAT MS27183-6 (96906)	EA	1										1A2A14MP11H3
X2H	5310-082-4007	WASHER, LOCK MS35338-41 (96906)	EA	1										1A2A14MP11H4
X2H		CLAMP, LOOP 14244 (02230)	EA	REF										1A2A14MP12
X2H	5310-013-4530	NUT, PLAIN, HEXAGON MS35649-62 (96906)	EA	1										1A2A14MP12H1
X2H		SCREW MACHINE MS35225-28 (96906)	EA	1										1A2A14MP12H2
X2H	5310-013-4530	WASHER, FLAT MS27183-6 (96906)	EA	1										1A2A14MP12H3
X2H	5310-045-4007	WASHER, LOCK MS35338-41 (96906)	EA	1										1A2A14MP12H4
X2H		CLAP, LOOP 15244 (02230)	EA	1										1A2A14MP13

SECTION II REPAIR PARTS FOR DIREST SUPPORT, GENERAL SUPPORT, AND DEPOT MAINTENANCE (CONTINUED)

(1) SMR CODE	(2) FEDERAL STOCK NUMBER	(3) DESCRIPTION USABLE ON CODE REFER. NO. & MFR. CODE	(4) UNIT OF MEAS	(5) QTY INC IN UNIT	(6) 30-DAY DS MAINT ALLOWANCE			(7) 30-DAY GS MAINT ALLOWANCE			(8) 1 YR ALW PER EQUIP CNTGCT	(9) DEPOT MAINT ALW PER 100 EQUIP	(10) ILLUSTRATIONS	
					(a)	(b)	©	(a)	(b)	©			(a)	(b)
					1-20	21-50	51-100	1-20	21-50	51-100			FIG. NO.	ITEM NO. OR REFERENCE DESIGNATION
X2H	5310-013-4530	NUT, PLAIN, HEXAGON MS35649-62 (96906)	EA	1										1A2A14MP13H1
X2H		SCREW MACHINE MS35225-28 (96906)	EA	1										1A2A14MP13H2
X2H	5310-082-1404	WASHER, FLAT MS27183-6 (96906)	EA	1										1A2A14MP13H3
X2H	5310-045-4007	WASHER, LOCK MS35338-41 (96906)	EA	1										1A2A14MP13H4
PH		CONNECTOR RECEPTACLE, ELECTRICAL 092444 (02230)	EA	1				*	*	2	5	3		1A2A14J4
X2H	5310-934-9739	NUT, PLAIN, HEXAGON MS35649-242 (96906)	EA	4										1A2A14J4H4
X2H	5305-889-2997	SCREW MACHINE MS35206-215 (96906)	EA	4										1A2A14J4H8
X2H		WASHER, LOCK MS35338-40 (96906)	EA	4										1A2A14J4H12
PH		CONNECTOR, RECEPTACLE, ELECTRICAL 052444 (002230)	EA	3				*	2	2	13	3		1A2A14J5
X2H	5305-558-3671	SCREW MACHINE MS35225-7 (96906)	EA	3										1A2A14J5H3
PH		CONNECTOR, RECEPTACLE, ELECTRICAL 182444 (02230)	EA	1				*	*	2	5	3	3-1	1A2A14J6
PH		CONNECTOR, RECEPTACLE, ELECTRICAL 302444 (02230)	EA	1				*	*	2	5	3	3-1	1A2A14J7
PH		CONNECTOR, RECEPTACLE, ELECTRICAL 052444 (02230)	EA	REF				REF	REF	REF	REF	REF	3-1	1A2A14J9
X2H		SCREW MACHINE MS35225-7 (96906)	EA	3										1A2A14J9H3
PH		CONNECTOR, RECEPTACLE, ELECTRICAL 062444 (02230)	EA	1				*	*	2	5	3	3-1	1A2A14J11
X2H		NUT, PLAIN, HEXAGON MS35649-42 (96906)	EA	3										1A2A14J1H3
X2H	5305-889-2997	SCREW MACHINE MS35206-215 (96906)	EA	3										1A2A14J1H6
X2H		WASHER, LOCK MS35338-40 (96906)	EA	3										1A2A14J11H9
PH		CONNECTOR, RECEPTACLE, ELECTRICAL 082444 (02230)	EA	1				*	*	2	5	3	3-1	1A2A14J12
X2H		SCREW MACHINE 192444 (02230)	EA	4										1A2A14J12H4
X2H		WASHER, NONMETALIC 202444 (02230)	EA	4										1A2A14J12H8
X2H		WASHER, NONMETALIC 212444 (02230)	EA	4										1A2A14J12H12
PH		CONNECTOR, RECEPTACLE, ELECTRICAL 062444 (02230)	EA	1				REF	REF	REP	REF	REF	3-1	1A2A14J13
X2H		SCREW MACHINE MS35225-7 (96906)	EA	3										1A2A14J13MP1H3
X2H		BRACKET, ANGLE 002642 (02230)	EA											1A2A14J13MP1

SECTION II REPAIR PARTS FOR DIREST SUPPORT, GENERAL SUPPORT, AND DEPOT MAINTENANCE (CONTINUED)

(1) SMR CODE	(2) FEDERAL STOCK NUMBER	(3) DESCRIPTION USABLE ON CODE REFER. NO. & MFR. CODE	(4) UNIT OF MEAS	(5) QTY INC IN UNIT	(6) 30-DAY DS MAINT ALLOWANCE			(7) 30-DAY GS MAINT ALLOWANCE			(8) 1 YR ALW PER EQUIP CNTGCT	(9) DEPOT MAINT ALW PER 100 EQUIP	(10) ILLUSTRATIONS	
					(a)	(b)	©	(a)	(b)	©			(a)	(b)
					1-20	21-50	51-100	1-20	21-50	51-100			FIG. NO.	ITEM NO. OR REFERENCE DESIGNATION
X2H		NUT, PLAIN, HEXAGON MS35649-62 (96906)	EA	2									1A2A14J13H2	
X2H		SCREW MACHINE MS35225-13 (96906)	EA	2									1A2A14J13H4	
X2H		WASHER, FLAT MS27183-3 (96906)	EA	2									1A2A14J13H6	
AHR		JACK TELEPHONE ASSEMBLY 012444 (02230)	EA	1								3-1	1A2A14J1	
PH		JACK TELEPHONE 002012 (02230)	EA	1				*	*	2	5	3	3-1 1A2A14J2	
X2H	5305-984-6189	SCREW MACHINE MS35406-241 (96906)	EA	3									1A2A14J2H3	
X2H	5310-045-3299	WASHER, LOCK MS35338-42 (96906)	EA	3									1A2A14J2H6	
PH		JACK TELEPHONE 022012 (02230)	EA	1				*	*	2	5	3	1A2A14J2J1	
X2H	5305-984-4982	SCREW MACHINE MS35206-225 (96906)	EA	1									1A2A14J2J1H1	
PH		JACK TELEPHONE 012012 (02230)	EA	1				*	*	2	5	3	1A2A14J2J2	
X2H		SCREW MACHINE MS35225-25 (96906)	EA	1									1A2A14J2J2H1	
MD		SPACER, PLATE 003252 (02230)	EA	1									1A2A14J2MP1	
PH		JACK TELEPHONE 022444 (02230)	EA	1				*	*	2	5	3	3-1 1A2A14J3	
X2H		SCREW MACHINE MS35225-25 (96906)	EA	1									1A2A14J3H1	
X2H		WASHER, LOCK MS35338-42 (96906)	EA	1									1A2A14J3H2	
PH		JACK TELEPHONE 072444 (02230)	EA	1				*	*	2	5	3	3-1 1A2A14J8	
MD		PANEL, TEST, ELECTRICAL 002533 (02230)	EA	1									1A2A14MP14	
PH	5915-752-3703	RESISTOR RA20LASB3ROA (81349)	EA	1				*	*	2	5	3	3-6 1A2A14R1	
PH	5905-752-7319	RESISTOR RA20LASB150A (81349)	EA	1				*	*	2	5	3	3-6 1A2A14R2	
MD		RETAINER, CLAMP, P, ASSEMBLY 002132 (02230)	EA	1									1A2MP2	
X2H	5305-989-7434	SCREW MACHINE MS35207-263 (96906)	EA	4									1A2MP2H4	
X2H	5310-809-8546	WASHER, FLAT MS27183-8 (96906)	EA	4									1A2MP2H8	
X2H		CLAMP, BOTTOM 002872 (02230)	EA	1									1A2MP2MP1	
X2H		CLAMP, TOP 002882 (02230)	EA	1									1A2MP2MP2	
X2H		THUMB SCREW 002142 (02230)	EA	1									1A2MP2MP3	

SECTION II REPAIR PARTS FOR DIREST SUPPORT, GENERAL SUPPORT, AND DEPOT MAINTENANCE (CONTINUED)

(1) SMR CODE	(2) FEDERAL STOCK NUMBER	(3) DESCRIPTION USABLE ON CODE REFER. NO. & MFR. CODE	(4) UNIT OF MEAS	(5) QTY INC IN UNIT	(6) 30-DAY DS MAINT ALLOWANCE			(7) 30-DAY GS MAINT ALLOWANCE			(8) 1 YR ALW PER EQUIP CNTGCTY	(9) DEPOT MAINT ALW PER 100 EQUIP	(10) ILLUSTRATIONS	
					(a)	(b)	©	(a)	(b)	©			(a)	(b)
					1-20	21-50	51-100	1-20	21-50	51-100			FIG. NO.	ITEM NO. OR REFERENCE DESIGNATION
MD		BOX, SPARE PARTS ASSEMBLY												
		003202 (02230)	EA	1									3-1	1A2A3
X2H		NUT, PLAIN, HEXAGON												1A2A3MP1H2
X2H		MS35649-62 (96906)	EA	2										1A2A3MP1H4
X2H		SCREW MACHINE												1A2A3MP1H6
X2H		MS35225-31 (96906)	EA	2										1A2A3MP1H8
X2H		WASHER, FLAT												
X2H		MS27183-5 (96906)	EA	2										
X2H		WASHER, LOCK												
X2H		MS35338-41 (96906)	EA	2										
MD		BOX, SPARE PARTS SUB ASSEMBLY												
		002853 (02230)	EA	1										1A2A3MP1
X2H		FASTENER, FLARE LOCK												1A2A3MP1H2
X2H		023202 (02230)	EA	2										1A2A3MP1H2H2
X2H		RIVET, TUBULAR												1A2A3MP1X20
X2H		023202 (02230)	EA	4										1A2A3MP1X20H1
X2H		CLIP, SPRING TENSION												
X2H		013202 (02230)	EA	20										
X2H		RIVET, TUBULAR												
X2H		043202 (02230)	EA	20										
MD		COVER, SPARE PARTS BOX												
		002123 (02230)	EA	1										1A2A3MP2
X2H		FASTENER, FLARE LOCK												1A2A3MP2H2
X2H		022123 (02230)	EA	2										1A2A3MP2MP1
X2H		BRACKET, ANGLE												1A2A3MP2MP1H2
X2H		003182 (02230)	EA	1										1A2A3MP2MP1H4
X2H		NUT, PLAIN, HEXAGON												1A2A3MP2MP1H6
X2H		MS35649-62 (96906)	EA	2										1A2A3MP2MP1MP2
X2H		SCREW MACHINE												
X2H		MS35225-28 (96906)	EA	2										
X2H		WASHER, LOCK												
X2H		MS35338-41 (96906)	EA	2										
X2H		GROMMET, RUBBER												
X2H		012122 (02230)	EA	2										
X2H		CLIP SPRING TENSION												
X2H		013202 (02230)	EA	10										
X2H		RIVET, TUBULAR												
X2H		043202 (02230)	EA	10										
PH		CONNECTOR, RECEPTACLE, ELECTRICAL												
		SMC380212 (80063)	EA	1				*	*	2	5	3		1A2A3MP2P1
X2H		RIVET, TUBULAR												1A2A3MP2MP1H2
AHR		SMB381320(80062)	EA	2										
		STAND, MICROPHONE, ASSEMBLY												
		002743 (02230)	EA	1										1A2A4
MD		COVER, MICROPHONE												
		A003012 (02230)	EA	1										1A2A4MP1
X2H	5305-958-5453	SCREW MACHINE												1A2A4MP1H4
		MS35190-236 (96906)	EA	4										
PH		THUMB SCREW												
		002172 (02230)	EA	1				*	*	2	5	3		1A2A4MP2

SECTION II REPAIR PARTS FOR DIREST SUPPORT, GENERAL SUPPORT, AND DEPOT MAINTENANCE (CONTINUED)

(1) SMR CODE	(2) FEDERAL STOCK NUMBER	(3) DESCRIPTION USABLE ON CODE REFER. NO. & MFR. CODE	(4) UNIT OF MEAS	(5) QTY INC IN UNIT	(6) 30-DAY DS MAINT ALLOWANCE			(7) 30-DAY GS MAINT ALLOWANCE			(8) 1 YR ALW PER EQUIP CNTGCT	(9) DEPOT MAINT ALW PER 100 EQUIP	(10) ILLUSTRATIONS	
					(a)	(b)	©	(a)	(b)	©			(a)	(b)
					1-20	21-50	51-100	1-20	21-50	51-100			FIG. NO.	ITEM NO. OR REFERENCE DESIGNATION
MD		BRACKET, MICROPHONE 002712 (02230)	EA	1										
PH	5330-584-1840	PACKING, PREFORMED MS28775-014 (96906)	EA	1				*	*	2	5	3		1A2A4A1
X2H		WASHER SHOULDERED AND RECESSED 002892 (02230)	EA	1										1A2A4A1MP1
X2H	5305-958-5473	SCREW MACHINE MS35190-251 (96906)	EA	1										1A2A4A1MP2
MD		BRACKET, MICROPHONE 002692 (02230)	EA	1									3-1	1A2A4A1MP2H1
PH	5330-584-1840	PACKING, PREFORMED MS28775-014 (96906)	EA	1				REF	REF	REF	REF	REF		1A2A4A2
AHR		HOLDER, MICROPHONE, ASSEMBLY 002932 (02230)	EA	1										1A2A4A2MP1
PH	5305-933-8220	THUMB SCREW 002902 (02230)	EA	1									3-1	1A2A4A3
X2H	5325-291-9366	GROMMET, RUBBER MS35489-11 (96906)	EA	1				*	*	2	5	3		1A2A4A3MP1
X2H		NUT, PLAIN, KNURLED 002922 (02230)	EA	1										1A2A4A3MP2
X2H		PIN, STRAIGHT, HEADLESS 002912 (02230)	EA	1										1A2A4A3MP3
MD		PLUNGER, DETENT 102952 (02230)	EA	1										1A2A4A3MP4
X2H		RETAINER SPRING, HELICAL CLIPS 002952 (02230)	EA	1										1A2A4A3MP5
PH		SPRING, HELICAL COMPRESSION 002102 (02230)	EA	1				*	*	2	5	3		1A2A4A3MP6
PH	5965-448-3744	MICROPHONE, DYNAMIC 002022 (02230)	EA	1				*	*	2	5	3	3-1	1A2A4A3MP7
PH		THUMB SCREW 002042 (02230)	EA	1				*	*	2	5	3		1A2A4A4
X2H		SUPPORT, MICROPHONE 002722 (02230)	EA	1				*	*	2	5	3		1A2A4A4MP2
X2H		WASHER SHOULDERED AND RECESSED 002892 (02230)	EA	1										1A2A4A4MP3
X2H		SCREW MACHINE MS35241-50 (96906)	EA	1										1A2A4MP3MP1
AHR		TEST RACK ASSEMBLY 001774 (02230)	EA	1									1-1	1A2A4MP3MP1H1
PH	6625-931-6806	DIAL, PERCENT BREAK ASSEMBLY SMC380235 (80063)	EA	1				1	1	1	5	2	3-2	1A3
X2H	5950-470-1432	PIN, LOCK 002272 (02230)	EA	1									3-15	1A3A9
X2H		NUT, PLAIN, HEXAGON MS35649-42 (96906)	EA	2										1A3A9MP1
X2H	5305-638-1716	SCREW MACHINE MS35223-17 (96906)	EA	2										1A3A9MP1H2
X2H		WASHER, FLAT MS27183-3 (96906)	EA	2										1A3A9MP1H4
														1A3A9MP1H6

SECTION II REPAIR PARTS FOR DIREST SUPPORT, GENERAL SUPPORT, AND DEPOT MAINTENANCE (CONTINUED)

(1) SMR CODE	(2) FEDERAL STOCK NUMBER	(3) DESCRIPTION USABLE ON CODE REFER. NO. & MFR. CODE	(4) UNIT OF MEAS	(5) QTY INC IN UNIT	(6) 30-DAY DS MAINT ALLOWANCE			(7) 30-DAY GS MAINT ALLOWANCE			(8) 1 YR ALW PER EQUIP CNTGCT	(9) DEPOT MAINT ALW PER 100 EQUIP	(10) ILLUSTRATIONS	
					(a)	(b)	©	(a)	(b)	©			(a)	(b)
					1-20	21-50	51-100	1-20	21-50	51-100			FIG. NO.	ITEM NO. OR REFERENCE DESIGNATION
X2H		WASHER, LOCK MS35335-15 (96906)	EA	2										1A3A9MP1H8
PH	5910-978-938	CAPACITOR, FIXED, ELECTROLYTIC CQ08A1MC682J1 (81349)	EA	1				*	*	2	8	3	3-15	1A3A9C1
PH	5910-913-3064	CAPACITOR, FIXED, ELECTROLYTIC CQ08A1MC684J1 (81349)	EA	1				*	*	2	8	3	3-15	1A3A9C2
PH	5910-056-8633	CAPACITOR, FIXED, ELECTROLYTIC CS12AG10K (81349)	EA	1				*	*	2	8	3	3-15	1A3A9C3
PH		CAPACITOR, FIXED, ELECTROLYTIC CS1BD686K (81349)	EA	1				*	*	2	8	3	3-15	1A3A9C4
PH		CONNECTOR, RECEPACLE, ELECTRICAL 212263	EA	1				*	*	2	8	3	3-15	1A3A9P1
X2H		NUT, PLAIN, HEXAGON MS35649-42 (96906)	EA	2										1A3A9P1MP1H2
X2H	5305-638-3286	SCREW MACHINE MS35223-18 (96906)	EA	2										1A3A9P1MP1H4
X2H		WASHER, FLAT MS27183-3 (96906)	EA	2										1A3A9P1MP1H6
X2H		WASHER, LOCK MS35335-15 (96906)	EA	2										1A3A9P1MP1H8
PH		PRINTED, WIRING, BOARD 003312 (02230)	EA	1				*	*	2	8	3	3-15	1A3A9E1
PH	5905-984-1464	RESISTOR, FIXED, FILM RN60B4752F (81349)	EA	1				*	*	2	8	3	3-15	1A3A9R1
PH	5905-195-6817	RESISTOR, FIXED, COMPOSITION RC20GF102K (81349)	EA	2				*	2	2	13	3	3-15	1A3A9R2
PH	5905-799-8512	RESISTOR FIXED, FILM RN60B3322F (81349)	EA	1				*	*	2	8	3	3-15	1A3A9R3
PH	5905-195-6817	RESISTOR, FIXED, COMPOSITION RC20GF102K (81349)	EA	REF				REF	REF	REF	REF	REF	3-15	1A3A9R4
PH	5905-471-6218	RESISTOR FIXED, WIRE, WOUND RB52AE16000C (81349)	EA	1				*	*	2	8	3	3-15	1A3A9R5
PH	5905-471-6217	RESISTOR, FIXED, WIRE, WOUND RB52AE10300C (81349)	EA	1				*	*	2	8	3	3-15	1A3A9R6
PH	5905-401-6628	RESISTOR FIXED, WIRE, WOUND RB52AE12000C (81349)	EA	1				*	*	2	8	3	3-15	1A3A9R7
PH	5905-471-6219	RESISTOR, FIXED, WIRE, WOUND RB52AE33601C (81349)	EA	1				*	*	2	8	3	3-15	1A3A9R8
PH	5905-195-6741	RESISTOR, FIXED, COMPOSITION RC20GF272K (81349)	EA	2				*	*	2	8	3	3-15	1A3A9R9, 1A3A9R10
PH	5961-842-9864	SEMICONDUCTOR, DEVICE DIODE IN914 (81349)	EA	3				*	2	2	13	24	3-15	1A3A9CR1
PH	5961-842-9864	SEMICONDUCTOR IN914 (81349)	EA	REF				REF	REF	REF	REF	REF	3-15	1A3A9CR2
PH	5961-842-9864	SEMICONDUCTOR IN914 (81349)	EA	REF				REF	REF	REF	REF	REF	3-15	1A3A9CR3
PH	5961-752-5229	TRANSISTOR USAF2N404 (81349)	EA	2				*	2	2	13	3	3-15	1A3A901
PH	5961-752-5229	TRANSISTOR USAF2N404 (81349)	EA	REF				REF	REF	REF	REF	REF	3-15	1A3A902

SECTION II REPAIR PARTS FOR DIREST SUPPORT, GENERAL SUPPORT, AND DEPOT MAINTENANCE (CONTINUED)

(1) SMR CODE	(2) FEDERAL STOCK NUMBER	(3) DESCRIPTION USABLE ON CODE REFER. NO. & MFR. CODE	(4) UNIT OF MEAS	(5) QTY INC IN UNIT	(6) 30-DAY DS MAINT ALLOWANCE			(7) 30-DAY GS MAINT ALLOWANCE			(8) 1 YR ALW PER EQUIP CNTGCTY	(9) DEPOT MAINT ALW PER 100 EQUIP	(10) ILLUSTRATIONS	
					(a) 1-20	(b) 21-50	© 51-100	(a) 1-20	(b) 21-50	© 51-100			(a) FIG. NO.	(b) ITEM NO. OR REFERENCE DESIGNATION
					PHS	6625-931-6804	DIAL, SPEED, ASSEMBLY SMC380236 (80063)	EA	1					
X2H	5950-470-1432	PIN, LOCK 002272 (02230)	EA	1									3-16	1A3A10MP1
X2H		NUT, PLAIN, HEXAGON MS35649-42 (96906)	EA	2										1A3A10MP1H2
X2H		SCREW MACHINE MS35223-17 (96906)	EA	2										1A3A10MP1H4
X2H		WASHER, FLAT MS27183-3 (96906)	EA	2										1A3A10MP1H6
X2H		WASHER, LOCK MS35335-15 (96906)	EA	2										1A3A10MP1H8
PH	5910-085-1230	CAPACITOR, FIXED, MICA DIELECTRIC CM15F101JN3 (81349)	EA	1				*	*	2	8	3	3-16	1A3A10C1
PH	5910-939-4596	CAPACITOR, FIXED, ELECTROLYTIC CQ08A1MC104J1 (81349)	EA	1				*	*	2	8	3	3-16	1A3A10C2
PH	5910-936-1334	CAPACITOR, FIXED, ELECTROLYTIC CS12BG105K (81349)	EA	1				*	*	2	8	3	3-16	1A3A10C3
PH	5910-104-1341	CAPACITOR, FIXED, ELECTROLYTIC CL64CH400MP3 (81349)	EA	1				*	*	2	8	3	3-16	1A3A10C4
PH	5910-045-0603	CAPACITOR, FIXED, ELECTROLYTIC CL64CE150MP3 (81349)	EA	1				*	*	2	8	3	3-16	1A3A10C5
PH		CONNECTOR RECEPTACLE, ELECTRICAL 212263 (02230)	EA	1				REF	REF	REF	REF	REF	3-16	1A3A10P1
X2H		NUT, PLAIN, HEXAGON MS35649-42 (96906)	EA	2										1A3A10P1MP1H2
X2H		SCREW MACHINE MS35223-18 (96906)	EA	2										1A3A10P1MP1H4
X2H		WASHER, FLAT MS27183-3 (96906)	EA	2										1A3A10P1MP1H6
X2H		WASHER, LOCK MS3335-15 (96906)	EA	2										1A3A10P1MP1H8
PH		PRINTED, WIRING, BOARD 003332 (02230)	EA	1				*	*	2	8	3	3-16	1A3A10E1
PH	5905-192-3982	RESISTOR, FIXED, COMPOSITION RC20GF105K (81349)	EA	1				*	*	2	8	3	3-16	1A3A10R1
PH	5905-192-3987	RESISTOR, FIXED, COMPOSITION RC20GF104K (81349)	EA	2				*	2	2	13	2	3-16	1A3A10R2
PH	5905-192-3987	RESISTOR FIXED, COMPOSITION RC20GF104K (81349)	EA	REF				REF	REF	REF	REF	REF	3-16	1A3A10R3
PH	5901-185-8510	RESISTOR, FIXED, COMPOSITION RC20GF103J (81349)	EA	1				*	*	2	8	3	3-16	1A3A10R4
PH	5905-245-0023	RESISTOR, FIXED, COMPOSITION RC20GF682K (81349)	EA	1				*	*	2	8	3	3-16	1A3A10R5
PH	5905-192-3988	RESISTOR FIXED, COMPOSITION RC20GF563K (81349)	EA	1				*	*	2	8	3	3-16	1A3A10R6
PH	5905-195-6809	RESISTOR, FIXED, COMPOSITION RC20GF122K (81349)	EA	1				*	*	2	8	3	3-16	1A3A10R7
PH	5905-577-2704	RESISTOR, FIXED, FILM RN60B8252F (81349)	EA	1				*	*	2	8	3	3-16	1A3A10R8

SECTION II REPAIR PARTS FOR DIREST SUPPORT, GENERAL SUPPORT, AND DEPOT MAINTENANCE (CONTINUED)

(1) SMR CODE	(2) FEDERAL STOCK NUMBER	(3) DESCRIPTION USABLE ON CODE REFER. NO. & MFR. CODE	(4) UNIT OF MEAS	(5) QTY INC IN UNIT	(6) 30-DAY DS MAINT ALLOWANCE			(7) 30-DAY GS MAINT ALLOWANCE			(8) 1 YR ALW PER EQUIP CNTGCTY	(9) DEPOT MAINT ALW PER 100 EQUIP	(10) ILLUSTRATIONS	
					(a)	(b)	©	(a)	(b)	©			(a)	(b)
					1-20	21-50	51-100	1-20	21-50	51-100			FIG. NO.	ITEM NO. OR REFERENCE DESIGNATION
PH	5905-279-1876	RESISTOR FIXED, COMPOSITION RC20GF222K (81349)	EA	1				*	*	2	8	3	3-16	1A3A10R9
PH	5905-186-3000	RESISTOR, FIXED, COMPOSITION RC20GF01J (81349)	EA	2				*	2	2	13	3	3-16	1A3A10R10
PH	5905-186-3000	RESISTOR, FIXED, COMPOSITION RC20GF101K (81349)	EA	REF				REF	REF	REF	REF	REF	3-16	1A3A10R11
PH	5905-171-2005	RESISTOR, FIXED, COMPOSITION RC20GF471K (81349)	EA	1				*	*	2	8	3	3-16	1A3A10R12
PH	5905-279-2672	RESISTOR, FIXED, COMPOSITION RC20GF182K (81349)	EA	1				*	*	2	8	3	3-16	1A3A10R13
PH	5905-257-2631	RESISTOR, FIXED, COMPOSITION RC20GF821K (81349)	EA	1				*	*	2	8	3	3-16	1A3A10R14
PH	5905-195-6451	RESISTOR, FIXED, COMPOSITION RC20GF472K (81349)	EA	1				*	*	2	8	3	3-16	1A3A10R15
PH	5961-842-9864	SEMICONDUCTOR IN914 (81349)	EA	4				REF	REF	REF	REF	REF	3-16	1A3A10CR1
PH	5961-842-9864	SEMICONDUCTOR IN914 (81349)	EA	REF				REF	REF	REF	REF	REF	3-16	1A3A10CR2
PH	5961-842-9864	SEMICONDUCTOR IN914 (81349)	EA	REF				REF	REF	REF	REF	REF	3-16	1A3A10CR3
PH	5961-842-9864	SEMICONDUCTOR IN914 (81349)	EA	REF				REF	REF	REF	REF	REF	3-16	1A3A10CR4
PH	5961-752-5229	TRANSISTOR USAFZN404 (81349)	EA	2				REF	REF	REF	REF	REF	3-16	1A3A10Q1
PH	5951-752-6810	TRANSISTOR USAFZN404 (81349)	EA	REF				REF	REF	REF	REF	REF	3-16	1A3A10Q2
AHR	6625-931-6810	METER, AMPLIFIER ASSEMBLY SMC380228(80063)	EA	1									3-2	1A3A2
X2H	5950-470-1432	PIN, LOCK 002272 (02230)	EA	1										1A3A2MP1
X2H		NUT, PLAIN, HEXAGON MS35649-42 (96906)	EA	2										1A3A2MP1H2
X2H		SCREW MACHINE MS35223-17 (96906)	EA	2										1A3A2MP1H4
X2H		WASHER, FLAT MS27183-3 (96906)	EA	2										1A3A2MP1H6
X2H		WASHER, LOCK MS35335-15 (96906)	EA	2										1A3A2MP1H8
PH	5910-782-1973	CAPACITOR, FIXED, ELECTROLYTIC CS13BE106K (81349)	EA	1				*	*	2	8	3	3-8	1A3A2C1
PH	5910-826-8911	CAPACITOR, FIXED, ELECTROLYTIC CS13BF393K (81349)	EA	1				*	*	2	8	3	3-8	1A3A2C2
PH	5910-936-1522	CAPACITOR, FIXED, ELECTROLYTIC CS13AE106M (81349)	EA	1				*	*	2	8	3	3-8	1A3A2C3
PH	5910-936-4820	CAPACITOR, FIXED, ELECTROLYTIC CS13BH104M (81349)	EA	2				*	2	2	13	3	3-8	1A3A2C4
PH	5910-899-9129	CAPACITOR, FIXED, ELECTROLYTIC CS13BD686M (81349)	EA	1				*	*	2	8	3	3-8	1A3A2C5
PH	5910-936-4820	CAPACITOR, FIXED, ELECTROLYTIC CS13BH104M (81349)	EA	REF				REF	REF	REF	REF	REF	3-8	1A3A2C6

SECTION II REPAIR PARTS FOR DIREST SUPPORT, GENERAL SUPPORT, AND DEPOT MAINTENANCE (CONTINUED)

(1) SMR CODE	(2) FEDERAL STOCK NUMBER	(3) DESCRIPTION USABLE ON CODE REFER. NO. & MFR. CODE	(4) UNIT OF MEAS	(5) QTY INC IN UNIT	(6) 30-DAY DS MAINT ALLOWANCE			(7) 30-DAY GS MAINT ALLOWANCE			(8) 1 YR ALW PER EQUIP CNTGCTY	(9) DEPOT MAINT ALW PER 100 EQUIP	(10) ILLUSTRATIONS	
					(a)	(b)	©	(a)	(b)	©			(a)	(b)
					1-20	21-50	51-100	1-20	21-50	51-100			FIG. NO.	ITEM NO. OR REFERENCE DESIGNATION
PH	5910-926-9785	CAPACITOR, FIXED , ELECTROLYTIC CS13BJ683K (81349)	EA	1				*	*	2	8	3	3-8	1A3A2C7
PH	5910-070-7654	CAPACITOR, FIXED, ELECTROLYTIC CS13BG822K (81349)	EA	2				*	2	2	13	3	3-8	1A3A2C8
PH	5910-934-2920	CAPACTOR, FIXED, ELECTROLYTIC CS13BF224M (81349)	EA	1				*	*	2	8	3	3-8	1A3A2C9
PH	5910-934-2921	CAPACITOR, FIXED, ELECTROLYTIC CS13BH154K (81349)	EA	1				*	*	2	8	3	3-8	1A3A2C10
PH	5910-070-7654	CAPACITOR, FIXED, ELECTROLYTIC CS13BG822K (81349)	EA	REF				REF	REF	REF	REF	REF	3-8	1A3A2C11
PH		CONNECTOR, RECEPTACLE, ELECTRICAL 212263 (02230)	EA	1				REF	REF	REF	REF	REF	3-8	1A3A2P1
X2H		NUT, PLAIN, HEXAGON MS35649-42 (96906)	EA	2										1A3A2P1MP1H2
X2H		SCREW MACHINE MS35223-18 (96906)	EA	2										1A3A2P1MP1H4
X2H		WASHER, FLAT MS27183-3 (96906)	EA	2										1A3A2P1MP1H6
X2H		WASHER, LOCK MS35335-15 (96906)	EA	2										1A3A2P1MP1H8
PH		PRINTED, WIRING, BOARD 003132 (02230)	EA	1				*	*	2	8	3	3-8	1A3A2E1
PH	5905-193-3981	RESISTOR, FIXED, COMPOSITION RC20GF124J (81349)	EA	1				*	*	2	8	3	3-8	1A3A2R1
PH	5905-190-8876	RESISTOR, FIXED, COMPOSITION RC20GF153K (81349)	EA	1				*	*	2	8	3	3-8	1A3A2R2
PH	5905-581-1054	RESISTOR, FIXED, FILM RN60B3403 (81349)	EA	1				*	*	2	8	3	3-8	1A3A2R3
PH	5905-185-8510	RESISTOR, FIXED, COMPOSITION RC20G103K (81349)	EA	3				REF	REF	REF	REF	REF	3-8	1A3A2R4
PH	5905-882-0438	RESISTOR, FIXED, FILM RN60B51R1F (81349)	EA	1				*	*	2	8	3	3-8	1A3A2R5
PH	5905-185-8510	RESISTOR, FIXED, COMPOSITION RC20GF03K (81349)	EA	REF				REF	REF	REF	REF	REF	3-8	1A3A2R6
PH	5905-969-5852	RESISTOR, FIXED, FILM RN60B1581F (81349)	EA	1				*	*	2	8	3	3-8	1A3A2R7
PH	5905-198-4565	RESISTOR, FIXED, COMPOSITION RC20GF683K (81349)	EA	2				*	2	2	13	3	3-8	1A3A2R8
PH	5905-195-6451	RESISTOR, FIXED, COMPOSITION RC20GF472K (81349)	EA	3				REF	REF	REF	REF	REF	3-8	1A3A2R9
PH	5905-245-0023	RESISTOR, FIXED COMPOSITION RC20GF682K (81349)	EA	1				REF	REF	REF	REF	REF	3-8	1A3A2R10
PH	5905-279-2621	RESISTOR, FIXED, COMPOSITION RC20GF330K (81349)	EA	1				*	*	2	8	3	3-8	1A3A2R11
PH	5905-198-4565	RESISTOR, FIXED, COMPOSITION RC20GF683K (81349)	EA	REF				REF	REF	REF	REF	REF	3-8	1A3A2R12
PH	5905-185-8510	RESISTOR, FIXED, COMPOSITION RC20GF103K (81349)	EA	REF				REF	REF	REF	REF	REF	3-8	1A3A2R13
PH	5905-279-3506	RESISTOR, FIXED, COMPOSITION RC20GF332K (81349)	EA	1				*	*	2	8	3	3-8	1A3A2R14

SECTION II REPAIR PARTS FOR DIREST SUPPORT, GENERAL SUPPORT, AND DEPOT MAINTENANCE (CONTINUED)

(1) SMR CODE	(2) FEDERAL STOCK NUMBER	(3) DESCRIPTION USABLE ON CODE REFER. NO. & MFR. CODE	(4) UNIT OF MEAS	(5) QTY INC IN UNIT	(6) 30-DAY DS MAINT ALLOWANCE			(7) 30-DAY GS MAINT ALLOWANCE			(8) 1 YR ALW PER EQUIP CNTGCTY	(9) DEPOT MAINT ALW PER 100 EQUIP	(10) ILLUSTRATIONS	
					(a) 1-20	(b) 21-50	© 51-100	(a) 1-20	(b) 21-50	© 51-100			(a) FIG. NO.	(b) ITEM NO. OR REFERENCE DESIGNATION
PH	5905-883-4840	RESISTOR, FIXED, FILM RN60B1540F (81349)	EA	1				*	*	2	8	3	3-8	1A3A2R15
PH	5905-195-6451	RESISTOR FIXED, COMPOSITION RC20GF472K (81349)	EA	REF				REF	REF	REF	REF	REF	3-8	1A3A2R16
PH	5905-190-8884	RESISTOR, FIXED, COMPOSITION RC20GF2I3K (81349)	EA	1				*	*	2	8	3	3-8	1A3A2R17
PH	5905-192-3987	RESISTOR, FIXED, COMPOSITION RC20GF104K (81349)	EA	1				*	*	2	8	3	3-8	1A3A2R18
PH	5905-190-8879	RESISTOR FIXED, COMPOSITION RC20GF183K (81349)	EA	1				*	*	2	8	3	3-8	1A3A2R19
PH	5905-795-451	RESISTOR, FIXED, COMPOSITION RC20GF472K (81349)	EA	REF				REF	REF	REF	REF	REF	3-8	1A3A2R20
PH	5905-279-2658	RESISTOR, FIXED, COMPOSITION RC20F820K (81349)	EA	1				*	*	2	8	3	3-8	1A3A2R21
PH	5905-195-5571	RESISTOR, FIXED, COMPOSITION RC20GF680J (81349)	EA	1				*	*	2	8	3	3-8	1A3A2R22
PH	5905-252-4018	RESISTOR, FIXED COMPOSITION RC20GF470K (81349)	EA	2				*	2	2	13	3	3-8	1A3A2R23
PH	5905-252-4018	RESISTOR, FIXED, COMPOSITION RC20GF470K (81349)	EA	REF				REF	REF	REF	REF	REF	3-8	1A3A2R24
PH	5961-669-6884	SEMICONDUCTOR, DEVICE, DIODE JAN IN 277 (81349)	EA	3				*	2	2	18	24	3-8	1A3A2CR1
PH	5961-669-6834	SEMICONDUCTOR JAN IN 277 (81349)	EA	REF				REF	REF	REF	REF	REF	3-8	1A3A2CR2
PH	5961-669-6884	SEMICONDUCTOR JAN IN 277 (81349)	EA	REF				REF	REF	REF	REF	REF	3-8	1A3A2CR3
PH	5961-785-3219	SEMICONDUCTOR, DEVICE, DIODE IN93A (81349)	EA	1				*	*	2	8	8	3-8	1A3A2CR4
PH	5961-752-0338	RESISTOR, THERMAL RB36L4 (73168)	EA	1				*	*	2	8	8	3-8	1A3A2RT1
PH	5961-752-0338	TRANSISTOR 2N43A (81349)	EA	5				*	2	2	27	3	3-8	1A3A2Q1
PH	5961-752-0338	TRANSISTOR 2N43A (81349)	EA	REF				REF	REF	REF	REF	REF	3-8	1A3A2Q2
PH	5961-752-0338	TRANSISTOR 2N43A (81349)	EA	REF				REF	REF	REF	REF	REF	3-8	1A3A2Q3
PH	5961-752-0338	TRANSISTOR 2N43A (81349)	EA	REF				REF	REF	REF	REF	REF	3-8	1A3A2Q4
PH	5961-752-0338	TRANSISTOR 2N43A (81349)	EA	REF				REF	REF	REF	REF	REF	3-8	1A3A2Q5
PH	5961-809-9047	TRANSISTOR 2N214 (81349)	EA	1				*	*	2	8	3	3-8	1A3A2Q6
PHS	6625-931-6812	NEGATIVE POWER SUPPLY ASSEMBLY SMC380232 (80063)	EA	1				1	1	1	5	2	3-2	1A3A6
X2H		PIN, LOCK 002272 (02230)	EA	1									3-12	1A3A6MP1
X2H		NUT, PLAIN, HEXAGON MS35649-42 (96906)	EA	2										1A3A6MP1H2
X2H		SCREW MACHINE MS35223-17 (96906)	EA	2										1A3A6MP1H4

SECTION II REPAIR PARTS FOR DIREST SUPPORT, GENERAL SUPPORT, AND DEPOT MAINTENANCE (CONTINUED)

(1) SMR CODE	(2) FEDERAL STOCK NUMBER	(3) DESCRIPTION USABLE ON CODE REFER. NO. & MFR. CODE	(4) UNIT OF MEAS	(5) QTY INC IN UNIT	(6) 30-DAY DS MAINT ALLOWANCE			(7) 30-DAY GS MAINT ALLOWANCE			(8) 1 YR ALW PER EQUIP CNTGCTY	(9) DEPOT MAINT ALW PER 100 EQUIP	(10) ILLUSTRATIONS	
					(a)	(b)	©	(a)	(b)	©			(a)	(b)
					1-20	21-50	51-100	1-20	21-50	51-100			FIG. NO.	ITEM NO. OR REFERENCE DESIGNATION
X2H		WASHER, FLAT MS27183-3 (96906)	EA	2										1A3A6MP1H6
X2H		WASHER, LOCK MS35335-15 (96906)	EA	2										1A3A6MP1H8
PH	5910-113-0260	CAPACITOR, FIXED, ELECTROLYTIC CL64CK500MP3 (81349)	EA	2				*	2	2	13	3	3-12	1A3A6C1
PH	5910-113-0260	CAPACITOR, FIXED, ELECTROLYTIC CL64CK500MP3 (81349)	EA	REF				REF	REF	REF	REF	REF	3-12	1A3A6C2
PH	5910-105-5478	CAPACITOR, FIXED, ELECTROLYTIC CL64CJ600MP3 (81349)	EA	2				*	2	2	13	3	3-12	1A3A6C3
PH	5910-105-5478	CAPACITOR, FIXED, ELECTROLYTIC CL64CJ600MP3 (81349)	EA	REF				REF	REF	REF	REF	REF	3-12	1A3A6C4
PH	5910-883-3286	CAPACITOR, FIXED, ELECTROLYTIC CL24BH111UP3 (81349)	EA	1				*	*	2	8	3	3-12	1A3A6C5
PH		CONNECTOR, RECEPTICAL, ELECTRICAL 212263 (02230)	EA	1				REF	REF	REF	REF	REF	3-12	1A3A6P1
X2H		NUT, PLAIN, HEXAGON MS35649-42 (96906)	EA	2										1A3A6P1MP1H2
X2H		SCREW MACHINE MS35223-18 (96906)	EA	2										1A3A6P1MP1H4
X2H		WASHER, FLAT MS27183-3 (96906)	EA	2										1A3A6P1MP1H6
X2H		WASHER, LOCK MS35335-15 (96906)	EA	2										1A3A6P1MP1H8
PH		PRINTED WIRING, BOARD 003302 (02230)	EA	1				*	*	2	8	3	3-12	1A3A6E1
PH		RESISTOR, FIE, WIRE, WOUND RW57V900 (81349)	EA	1				*	*	2	8	3	3-12	1A3A6R1
MD		HEAT SINK, ELECTRONIC COMPONENT 003382 (02230)	EA	1										1A3A6R1MP1
X2H	5310-687-6293	NUT, PLAIN, HEXAGON MS35649-22 (96906)	EA	1										1A3A6R1MP1H2
X2H	5310-087-0057	WASHER, FLAT MS27183-2 (96906)	EA	2										1A3A6R1MP1H4
X2H	5310-515-8000	WASHER, LOCK MS35337-39 (96906)	EA	2										1A3A6R1MP1H6
X2H		CLIP, SPRING TENSION 013382 (02230)	EA	1										1A3A6R1MP1MP1
X2H		NUT, PLAIN, HEXAGON MS35649-22 (96906)	EA	2										1A3A6R1MP1MP3
X2H	5305-816-9242	SCREW MACHINE MS35239-15 (96906)	EA	2										1A3A6R1MP1MP5
X2H		SPACER, PLATE 003342 (02230)	EA	3										1A3A6R1MP1MP6
X2H		SPACER, PLATE 003342 (02230)	EA	REF										1A3A6R1MP1MP7
X2H		SPACE, PLATE 003342 (02230)	EA	REF										1A3A6R1MP1MP8
X2H		WASHER, FLAT MS27183-2 (96906)	EA	4										1A3A6R1MP1MP12

SECTION II REPAIR PARTS FOR DIREST SUPPORT, GENERAL SUPPORT, AND DEPOT MAINTENANCE (CONTINUED)

(1) SMR CODE	(2) FEDERAL STOCK NUMBER	(3) DESCRIPTION USABLE ON CODE REFER. NO. & MFR. CODE	(4) UNIT OF MEAS	(5) QTY INC IN UNIT	(6) 30-DAY DS MAINT ALLOWANCE			(7) 30-DAY GS MAINT ALLOWANCE			(8) 1 YR ALW PER EQUIP CNTGCTY	(9) DEPOT MAINT ALW PER 100 EQUIP	(10) ILLUSTRATIONS	
					(a) 1-20	(b) 21-50	⊙ 51-100	(a) 1-20	(b) 21-50	⊙ 51-100			(a) FIG. NO.	(b) ITEM NO. OR REFERENCE DESIGNATION
X2H		INSULATION, SLEEVING ELECTRICAL PVC-105/15 (92194)	EA	2										1A3A6R1E1
X2H		INSULATION, SLEEVING, ELECTRICAL PVC-105/15 (92194)	EA	REF										1A3A6R1E2
PH	5905-185-6575	RESISTOR, FIXED, COMPOSITION RC20GF392K (81349)	EA	1				*	*	2	8	3	3-12	1A3A6R2
PH	5905-195-6817	RESISTOR FIXED, COMPOSITION RC20GF102K (81349)	EA	1				*	*	2	8	3	3-12	1A3A6R3
PH	5905-195-6809	RESISTOR, FIXED, COMPOSITION RC20GF122K (81349)	EA	1				*	*	2	8	3	3-12	1A3A6R4
PHS	6625-938-6813	NOISE GENERATOR ASSEMBLY SMC380229 (80063)	EA	1				1	1	1	5	2	3-2	1A3A3
X2H	5950-970-1432	PIN, LOCK 002272 (02230)	EA	1									3-9	1A3A3MP1
X2H		NUT, PLAIN, HEXAGON MS35649-42 (96906)	EA	2										1A3A3MP1H2
X2H		SCREW MACHINE MS35223-17 (96906)	EA	2										1A3A3MP1H4
X2H		WASHER, FLAT MS27183-3 (96906)	EA	2										1A3A3MP1H6
X2H		WASHER, LOCK MS35335-15 (96906)	EA	2										1A3A3MP1H8
PH	5910-105-8476	CAPACITOR, FIXED, ELECTROLYTIC CL64CH080MP3 (81349)	EA	2				*	2	2	13	3	3-9	1A3A3C1
PH	5910-926-9786	CAPACITOR, FIXED, ELECTROLYTIC CS12BB157K (81349)	EA	3				*	2	2	18	3	3-9	1A3A3C2
PH		CAPACITOR FIXED, ELECTROLYTIC CL24BH111UP3 (81349)	EA	1				*	*	2	8	3	3-9	1A3A3C3
PH	5910-835-2175	CAPACITOR, FIXED, PAPER DIELECTRIC CP09A1EB103K1 (81349)	EA	1				*	*	2	8	3	3-9	1A3A3C4
PH	5910-840-6570	CAPACITOR, FIXED, PAPER DIELECTRIC CP09A1EC682K1 (81349)	EA	1				*	*	2	8	3	3-9	1A3A3C5
PH	5910-926-9786	CAPACITOR, FIXED, ELECTROLYTIC CS12BB157K (81349)	EA	REF				REF	REF	REF	REF	REF	3-9	1A3A3C6
PH	5910-894-4546	CAPACITOR, FIXED, PAPER DIELECTRIC CP09A1EC472K1 (81349)	EA	1				*	*	2	8	3	3-9	1A3A3C7
PH	5910-105-5476	CAPACITOR, FIXED, ELECTROLYTIC CL64CH080MP3 (81349)	EA	REF				REF	REF	REF	REF	REF	3-9	1A3A3C8
PH		CAPACITOR, FIXED, ELECTROLYTIC CS12BB157K (81349)	EA	REF				REF	REF	REF	REF	REF	3-9	1A3A3C9
PH		CAPACITOR, FIXED, ELECTROLYTIC CS13BD686M (81349)	EA	1				REF	REF	REF	REF	REF	3-9	1A3A3C10
PH		CONNECTOR, RECEPTICAL, ELECTRICAL 212263 (02230)	EA	1				REF	REF	REF	REF	REF	3-9	1A3A3P1
X2H		NUT, PLAIN, HEXAGON MS35649-42 (96906)	EA	2										1A3A3P1MP1H2
X2H		SCREW MACHINE MS35223-18 (96906)	EA	2										1A3A3P1MP1H4
X2H		WASHER, FLAT MS27183-3 (96906)	EA	2										1A3A3P1MP1H6

SECTION II REPAIR PARTS FOR DIREST SUPPORT, GENERAL SUPPORT, AND DEPOT MAINTENANCE (CONTINUED)

(1) SMR CODE	(2) FEDERAL STOCK NUMBER	(3) DESCRIPTION USABLE ON CODE REFER. NO. & MFR. CODE	(4) UNIT OF MEAS	(5) QTY INC IN UNIT	(6) 30-DAY DS MAINT ALLOWANCE			(7) 30-DAY GS MAINT ALLOWANCE			(8) 1 YR ALW PER EQUIP CNTGCT	(9) DEPOT MAINT ALW PER 100 EQUIP	(10) ILLUSTRATIONS	
					(a)	(b)	©	(a)	(b)	©			(a)	(b)
					1-20	21-50	51-100	1-20	21-50	51-100			FIG. NO.	ITEM NO. OR REFERENCE DESIGNATION
X2H		WASHER, LOCK MS35335-5 (96906)	EA	2										1A3A3PMH8
PH		PRINTED WIRING BOARD 002652 (02230)	EA	1				*	*	2	8	3	3-9	1A3A3E1
PH	5905-993-2263	RESISTOR FIXED, FILM RN65B4221F (81349)	EA	2				*	2	2	13	3	3-9	1A3A3R1
PH	5905-553-3779	RESISTOR, FIXED, FILM RN65B1002F (81349)	EA	1				*	*	2	8	3	3-9	1A3A3R2
PH	5905-577-1869	RESISTOR, FIXED, FILM RN65B1001F (81349)	EA	1				*	*	2	8	3	3-9	1A3A3R3
PH	5905-192-3972	RESISTOR, FIXED, COMPOSITION RC20GF391K (81349)	EA	1				*	*	2	8	3	3-9	1A3A3R4
PH	5905-577-6765	RESISTOR, FIXED, FILM RN65B5110F (81349)	EA	1				*	*	2	8	3	3-9	1A3A3R5
PH	5905-988-2319	RESISTOR, FIXED, FILM RN65B1502F (81349)	EA	1				*	*	2	8	3	3-9	1A3A3R6
PH	5905-577-2829	RESISTOR, FIXED, FILM RN65B5622F (81349)	EA	1				*	*	2	8	3	3-9	1A3A3R7
PH	5905-615-7730	RESISTOR FIXED, FILM RN65B4641F (81349)	EA	1				*	*	2	8	3	3-9	1A3A3R8
PH	5905-855-5306	RESISTOR, FIXED FILM RN65B1501F (81349)	EA	1				*	*	2	8	3	3-9	1A3A3R9
PH	5905-542-7826	RESISTOR, FIXED, FILM RN65B4642F (81349)	EA	1				*	*	2	8	3	3-9	1A3A3R10
PH	5905-993-2263	RESISTOR, FIXED, FILM RN65B4221F (81349)	EA	REF				REF	REF	REF	REF	REF	3-9	1A3A3R11
PH		RESISTOR, FIXED COMPOSITION RC20GF153K (81349)	EA	1				*	*	2	8	3	3-9	1A3A3R12
PH	5905-192-3988	RESISTOR, FIXED, COMPOSITION RC20GF563K (81349)	EA	1				REF	REF	REF	REF	REF	3-9	1A3A3R13
PH	5905-195-6451	RESISTOR, FIXED, COMPOSITION RC20GF472K (81349)	EA	1				REF	REF	REF	REF	REF	3-9	1A3A3R14
PH	5905-195-5514	RESISTOR, FIXED, COMPOSITION RC20GF152K (81349)	EA	1				*	*	2	8	3	3-9	1A3A3R15
PH	5961-577-3022	TRANSISTOR JAN 2N220 (81349)	EA	3				*	2	2	18	3	3-9	1A3A3Q1
PH	5961-577-3022	TRANSISTOR JAN 2N220 (81349)	EA	REF				REF	REF	REF	REF	REF	3-9	1A3A3Q2
PH	5961-577-3022	TRANSISTOR JAN 2N220 (81349)	EA	REF				REF	REF	REF	REF	REF	3-9	1A3A3Q3
PHS	6625-931-6815	POSITIVE POWER SUPPLY ASSEMBLY SMC380231 (80063)	EA	1				1	1	1	5	2	3-2	1A3A5
X2H	5950-470-1432	PIN LOCK 002272 (02230)	EA	1									3-11	1A3A5MP1
X2H		NUT, PLAIN, HEXAGON MS35649 (96906)	EA	2										1A3A5MP1H2
X2H		SCREW MACHINE MS35223-17 (96906)	EA	2										1A3A5MP1H4
X2H		WASHER, FLAT MS27183-3 (96906)	EA	2										1A3A5MP1H6

SECTION II REPAIR PARTS FOR DIRECT SUPPORT, GENERAL SUPPORT, AND DEPOT MAINTENANCE (CONTINUED)

(1) SMR CODE	(2) FEDERAL STOCK NUMBER	(3) DESCRIPTION USABLE ON CODE REFER. NO. & MFR. CODE	(4) UNIT OF MEAS	(5) QTY INC IN UNIT	(6) 30-DAY DS MAINT ALLOWANCE			(7) 30-DAY GS MAINT ALLOWANCE			(8) 1 YR ALW PER EQUIP CNTGCT	(9) DEPOT MAINT ALW PER 100 EQUIP	(10) ILLUSTRATIONS	
					(a)	(b)	©	(a)	(b)	©			(a)	(b)
					1-20	21-50	51-100	1-20	21-50	51-100			FIG. NO.	ITEM NO. OR REFERENCE DESIGNATION
X2H		WASHER, LOCK MS35335-15 (96906)	EA	2										1A3A5MP1H8
PH	5910-113-0260	CAPACITOR, FIXED, ELECTROLYTIC CL64CK500MP3 (81349)	EA	2				REF	REF	REF	REF	REF	3-11	1A3A5C1
PH	5910-113-0260	CAPACITOR, FIXED ELECTROLYTIC CL64CK500MP3 (81349)	EA	REF				REF	REF	REF	REF	REF	3-11	1A3A5C2
PH	5910-105-5478	CAPACITOR, FIXED, ELECTROLYTIC CL64CJ600MP3 (81349)	EA	1				REF	REF	REF	REF	REF	3-11	1A3A5C3
PH	5910-113-0280	CAPACITOR, FIXED, ELECTROLYTIC CL44BG181TP3 (81349)	EA	1				*	*	2	8	3	3-11	1A3A5C4
PH	5910-827-3577	CAPACITOR FIXED, ELECTROLYTIC CL35BQ200MP3 (81349)	EA	1				*	*	2	8	3	3-11	1A3A5C5
PH		CONNECTOR, RECEPTICAL, ELECTRICAL 212263 (02230)	EA	1				REF	REF	REF	REF	REF	3-11	1A3A5P1
X2H		NUT, PLAN, HEXAGON MS35649-42 (96906)	EA	2										1A3A5P1MP1H2
X2H		SCREW MACHINE MS35223-18 (96906)	EA	2										1A3A5P1MP1H4
X2H		WASHER, FLAT MS27183-3 (96906)	EA	2										1A3A5P1MP1H6
X2H		WASHER, LOCK MS35335-15 (96906)	EA	2										1A3A5P1MP1H8
PH		PRINTED WIRING BOARD 003272 (02230)	EA	1				*	*	2	8	3	3-11	1A3A5E1
PH		RESISTOR, FIXED, WIRE WOUND RW7V500 (81349)	EA	1				*	*	2	8	3	3-11	1A3A5R1
MD		HEAT SINK, ELECTRONIC COMPONENT 003382 (02230)	EA	1										1A3A5R1MP1
X2H		NUT, PLAIN, HEXAGON MS35649-22 (96906)	EA	2										1A3A5R1MP1H2
X2H		WASHER, FLAT MS27183-2 (96906)	EA	2										1A3A5R1MP1H4
X2H		WASHER, LOCK MS35337-39 (96906)	EA	2										1A3A5R1MP1H6
X2H		CLIP, SPRING TENSION 013382 (02230)	EA	1										1A3A5R1MP1MP1
X2H		NUT, PLAIN, HEXAGON MS35649-22 (96906)	EA	2										1A3A5R1MP1MP3
X2H		SCREW MACHNE MS35239-15 (96906)	EA	2										1A3A5R1MP1MP5
X2H		SPACER, PLATE 033342 (02230)	EA	3										1A3A5R1MP1MP6
X2H		SPACER, PLATE 003342 (02230)	EA	REF										1A3A5R1MP1MP7
X2H		SPACER, PLATE 003342 (02230)	EA	REF										1A3A5R1MP1MP8
X2H		WASHER, FLAT MS27183-2 (96906)	EA	4										1A3A5R1MP1MP12
X2H		INSULATION, SLEEVING, ELECTRICAL PVC-105/15 (92194)	EA	2										1A3A5R1E1

SECTION II REPAIR PARTS FOR DIRECT SUPPORT, GENERAL SUPPORT, AND DEPOT MAINTENANCE (CONTINUED)

(1) SMR CODE	(2) FEDERAL STOCK NUMBER	(3) DESCRIPTION USABLE ON CODE REFER. NO. & MFR. CODE	(4) UNIT OF MEAS	(5) QTY INC IN UNIT	(6) 30-DAY DS MAINT			(7) 30-DAY GS MAINT			(8) 1 YR ALW PER EQUIP CNTGCTY	(9) DEPOT MAINT ALW PER 100 EQUIP	(10) ILLUSTRATIONS	
					ALLOWANCE			ALLOWANCE					(a) FIG. NO.	(b) ITEM NO. OR REFERENCE DESIGNATION
					(a) 1-20	(b) 21-50	© 51-100	(a) 1-20	(b) 21-50	© 51-100				
X2H		INSULATION, SLEEVING, ELECTRICAL PVC-105/15 (92194)	EA	REF										1A3A5R1E2
PH		RESISTOR, FIXED WIRE WOUND RW57V400 (81349)	EA	1				*	*	2	8	3	3-11	1A3A5R2
MD		HEAT SINK, ELECTRONIC COMPONENT 003382 (02230)	EA	1										1A3A5R2MP1
X2H		NUT, PLAIN, HEXAGON MS35649-22 (96906)	EA	2										1A3A5R2MP1H2
X2H		WASHER, FLAT MS27183-2 (96906)	EA	2										1A3A5R2MP1H4
X2H		WASHER, LOCK MS35337-39 (96906)	EA	2										1A3A5R2MP1H6
X2H		CLIP, SPRING TENSION 013382 (02230)	EA	1										1A3A5R2MP1MP1
X2H		NUT, PLAIN, HEXAGON MS35649-22 (96906)	EA	2										1A3A5R2MP1MP3
X2H		SCREW MACHINE MS35239-15 (96906)	EA	2										1A3A5R2MP1MP5
X2H		SPACER, PLATE 003342 (02230)	EA	3										1A3A5R2MP1MP6
X2H		SPACER, PLATE 003342 (02230)	EA	REF										1A3A5R2MP1MP7
X2H		SPACER, PLATE 003342 (02230)	EA	REF										1A3A5R2MP1MP8
X2H		WASHER, FLAT MS27183-2 (96906)	EA	4										1A3A5R2MP1MP12
X2H		INSULATION, SLEEVING, ELECTRICAL PVC-105/15 (92194)	EA	2										1A3A5R2E1
XZH		INSULATION, SLEEVING, ELECTRICAL PVC-105/15 (92194)	EA	REF										1A3A5R2E2
PH	5905-583-6005	RESISTOR, FIXED WIRE WOUND RW59V251 (81349)	EA	1				*	*	2	8	3	3-11	1A3A5R3
MD		HEAT SINK, ELECTRONIC COMPONENT 003392 (02230)	EA	1										1A3A5R3MP1
X2H		NUT, PLAIN, HEXAGON MS35649-22 (96906)	EA	2										1A3A5R3MP1H2
X2H		WASHER, FLAT MS27183-2 (96906)	EA	2										1A3A5R3MP1H4
X2H		WASHER, LOCK MS35337-39 (96906)	EA	2										1A3A5R3MP1H6
X2H		CLIP, SPRING TENSION 003392 (02230)	EA	1										1A3A5R3MP1MP1
X2H		NUT, PLAIN, HEXAGON MS35649-22 (96906)	EA	2										1A3A5R3MP1MP3
X2H		SCREW MACHINE MS35239-15 (96906)	EA	2										1A3A5R3MP1MP5
MD		SPACER, PLATE 003352 (02230)	EA	3										1A3A5R3MP1MP6
MD		SPACER PLATE 003352 (02230)	EA	REF										1A3A5R3MP1MP7

SECTION II REPAIR PARTS FOR DIRECT SUPPORT, GENERAL SUPPORT, AND DEPOT MAINTENANCE (CONTINUED)

(1) SMR CODE	(2) FEDERAL STOCK NUMBER	(3) DESCRIPTION USABLE ON CODE REFER. NO. & MFR. CODE	(4) UNIT OF MEAS	(5) QTY INC IN UNIT	(6) 30-DAY DS MAINT ALLOWANCE			(7) 30-DAY GS MAINT ALLOWANCE			(8) 1 YR ALW PER EQUIP CNTGCT	(9) DEPOT MAINT ALW PER 100 EQUIP	(10) ILLUSTRATIONS	
					(a) 1-20	(b) 21-50	© 51-100	(a) 1-20	(b) 21-50	© 51-100			(a) FIG. NO.	(b) ITEM NO. OR REFERENCE DESIGNATION
					MD		SPACER, PLATE 003352 (02230)	EA	REF					
X2H		WASHER FLAT MS27183-2 (96906)	EA	4										1A3A5R3MP1MP12
X2H		INSULATION, SLEEVING, ELECTRICAL PVC-105/15 (92194)	EA	2										1A3A5R3E1
X2H		INSULATION, SLEEVING, ELECTRICAL PVC-105/15 (92194)	EA	REF										1A3A5R3E2
PH	5905-195-6817	RESISTOR, FIXED COMPOSITION RC20GF102K (81349)	EA	1				REF	REF	REF	REF	REF	3-11	1A3A5R4
PH	5905-185-8521	RESISTOR, FIXED COMPOSITION RC42GF103K (81349)	EA	1				*	*	2	8	3	3-11	1A3A5R5
MD		HEAT SINK, ELECTRONIC COMPONENT 003392 (02230)	EA	1										1A3A5R5MP1
X2H		NUT, PLAIN, HEXAGON MS35649-22 (96906)	EA	2										1A3A5R5MP1H2
X2H		WASHER, FLAT MS27183-2 (96906)	EA	2										1A3A5R5MP1H4
X2H		WASHER, LOCK MS35337-39 (96906)	EA	2										1A3A5R5MP1H6
X2H		CLIP, SPRING TENSION 013392 (02230)	EA	1										1A3A5R5MP1MP1
X2H		NUT, PLAIN, HEXAGON MS35649-22 (96906)	EA	2										1A3A5R5MP1MP3
X2H		SCREW MACHINE MS35239-15 (96906)	EA	2										1A3A5R5MP1MP5
MD		SPACER, PLATE 003352 (02230)	EA	3										1A3A5R5MP1MP6
MD		SPACER, PLATE 003352 (02230)	EA	REF										1A3A5R5MP1MP7
MD		SPACER, PLATE 003352 (02230)	EA	REF										1A3A5R5MP1MP8
X2H		WASHER, FLAT MS27183-2 (96906)	EA	4										1A3A5R5MP1MP12
X2H		INSULATION, SLEEVING, ELECTRICAL PVC-105/15 (92194)	EA	2										1A3A5R5E1
X2H		INSULATION SLEEVING, ELECTRICAL PVC-105/15 (92194)	EA	REF										1A3A5R5E2
PH	5961-577-6214	SEMICONDUCTO, DEVICE DIODE IN538 (81349)	EA	2				*	*2	2	13	16	3-11	1A3A5CR1
PH	5961-577-6214	SEMICONDUCTOR IN538 (81349)	EA	REF				REF	REF	REF	REF	REF	3-11	1A3A5CR2
PH		SEMICONDUCTOR, DEVICE DIODE JAN IN540 (81349)	EA	2				*	2	2	13	16	3-11	1A3A5CR3
PH		SEMICONDUCTOR JAN IN540 (81349)	EA	REF				REF	REF	REF	REF	REF	3-11	1A3A5CR4
PHS	6625-931-6809	PREAMPLIFIER ASSEMBLY SMC380226 (80063)	EA	1				1	1	1	5	2	3-2	1A3A1
X2H	5950-470-1432	PIN LOCK 002272 (02230)	EA	1									3-7	1A3A1MP1

SECTION II REPAIR PARTS FOR DIRECT SUPPORT, GENERAL SUPPORT, AND DEPOT MAINTENANCE (CONTINUED)

(1) SMR CODE	(2) FEDERAL STOCK NUMBER	(3) DESCRIPTION USABLE ON CODE REFER. NO. & MFR. CODE	(4) UNIT OF MEAS	(5) QTY INC IN UNIT	(6) 30-DAY DS MAINT ALLOWANCE			(7) 30-DAY GS MAINT ALLOWANCE			(8) 1 YR ALW PER EQUIP CNTGCT	(9) DEPOT MAINT ALW PER 100 EQUIP	(10) ILLUSTRATIONS	
					(a)	(b)	©	(a)	(b)	©			(a)	(b)
					1-20	21-50	51-100	1-20	21-50	51-100			FIG. NO.	ITEM NO. OR REFERENCE DESIGNATION
X2H		NUT, PLAIN, HEXAGON MS35649-42 (96906)	EA	2										1A3A1MP1H2
X2H		SCREW, MACHINE MS35223-17 (96906)	EA	2										1A3A1MP1H4
X2H		WASHER, FLAT MS27183-3 (96906)	EA	2										1A3A1MP1H6
X2H		WASHER, LOCK MS35335-15 (96906)	EA	2										1A3A1MP1H8
PH		CAPACITOR FIXED, ELECTROLYTIC CS13AE106M (81349)	EA	2				REF	REF	REF	REF	REF	3-7	1A3A1C1
PH	5910-018-1944	CAPACITOR FIXED, ELECTROLYTIC CS12AC336M (81349)	EA	2				*	2	2	13	3	3-7	1A3A1C2
PH		CAPACITOR FIXED, ELECTROLYTIC CS13BD686M (81349)	EA	2				REF	REF	REF	REF	REF	3-7	1A3A1C3
PH		CAPACITOR FIXED, ELECTROLYTIC CS13AE106M (81349)	EA	REF				REF	REF	REF	REF	REF	3-7	1A3A1C4
PH	5910-823-1538	CAPACITOR FIXED, PAPER DIELECTRIC CP05A1KC223K3 (81349)	EA	1				*	*	2	8	3	3-7	1A3A1C5
PH	5910-018-1944	CAPACITOR FIXED, ELECTROLYTIC CS12AC336M (81349)	EA	REF				REF	REF	REF	REF	REF	3-7	1A3A1C6
PH		CAPACITOR FIXED, ELECTROLYTIC CS13BD686M (81349)	EA	REF				REF	REF	REF	REF	REF	3-7	1A3A1C7
PH	5910-781-8983	CAPACITOR, FIXED, ELECTROLYTIC CS13BE156K (81349)	EA	1				*	*	2	8	3	3-7	1A3A1C8
PH	5910-926-0064	CAPACITOR FIXED, ELECTROLYTIC CS13BE225M (81349)	EA	1				*	*	2	8	3	3-7	1A3A1C9
PH		CONNECTOR PLUG, ELECTRICAL 212263 (02230)	EA	REF				REF	REF	REF	REF	REF	3-7	1A3A1P1
X2H		NUT, PLAIN, HEXAGON MS35649-42 (96906)	EA	2										1A3A1P1MP1H2
X2H		SCREW, MACHINE MS35223-18 (96906)	EA	2										1A3A1P1MP1H4
X2H		WASHER, FLAT MS27183-3 (96906)	EA	2										1A3A1P1MP1H6
X2H		WASHER, LOCK MS35335-15 (96906)	EA	2										1A3A1P1MP1H8
PH		PRINTED WIRING BOARD 003242 (02230)	EA	1				*	*	2	8	3	3-7	1A3A1E1
PH	5905-198-4568	RESISTOR, FIXED, COMPOSITION RC20GF683K (81349)	EA	2				REF	REF	REF	REF	REF	3-7	1A3A1R1
PH	5905-171-1985	RESISTOR, FIXED, COMPOSITION RC20GF822K (81349)	EA	2				*	2	2	13	3	3-7	1A3A1R2
PH	5905-171-1985	RESISTOR, FIXED, COMPOSITION RC20GF822K (81349)	EA	REF				REF	REF	REF	REF	REF	3-7	1A3A1R3
PH	5905-195-5514	RESISTOR, FIXED, COMPOSITION RC20GF152K (81349)	EA	2				REF	REF	REF	REF	REF	3-7	1A3A1R4
PH	5905-978-7113	RESISTOR, FIXED FILM RN65B10ROF (81349)	EA	2				*	2	2	13	3	3-7	1A3A1R5
PH	5905-256-0387	RESISTOR, FIXED COMPOSITION RC20GF681K (81349)	EA	2				*	2	2	13	3	3-7	1A3A1R6

SECTION II REPAIR PARTS FOR DIRECT SUPPORT, GENERAL SUPPORT, AND DEPOT MAINTENANCE (CONTINUED)

(1) SMR CODE	(2) FEDERAL STOCK NUMBER	(3) DESCRIPTION USABLE ON CODE REFER. NO. & MFR. CODE	(4) UNIT OF MEAS	(5) QTY INC IN UNIT	(6) 30-DAY DS MAINT ALLOWANCE			(7) 30-DAY GS MAINT ALLOWANCE			(8) 1 YR ALW PER EQUIP CNTGCT	(9) DEPOT MAINT ALW PER 100 EQUIP	(10) ILLUSTRATIONS	
					(a)	(b)	©	(a)	(b)	©			(a)	(b)
					1-20	21-50	51-100	1-20	21-50	51-100			FIG. NO.	ITEM NO. OR REFERENCE DESIGNATION
PH	5905-198-4565	RESISTOR, FIXED, COMPOSITION RC20GF683K (81349)	EA	REF				REF	REF	REF	REF	REF	3-7	1A3A1R7
PH	5905-185-5810	RESISTOR, FIXED, COMPOSITION RC20GF103J (81349)	EA	1				*	*	2	8	3	3-7	1A3A1R8
PH	5905-914-5532	RESISTOR, FIXED, FILM RN60B8873F (81349)	EA	1				*	*	2	8	3	3-7	1A3A1R9
PH	5905-245-0023	RESISTOR, FIXED, COMPOSITION RC20GF682K (81349)	EA	1				REF	REF	REF	REF	REF	3-7	1A3A1R10
PH	5905-279-2672	RESISTOR, FIXED, COMPOSITION RC20GF182K (81349)	EA	1				REF	REF	REF	REF	REF	3-7	1A3A1R11
PH	5905-069-3913	RESISTOR, FIXED, FILM RN60B2740E (81349)	EA	1				*	*	2	8	3	3-7	1A3A1R12
PH	5905-256-0387	RESISTOR, FIXED, COMPOSITION RC20GF681K (81349)	EA	REF				REF	REF	REF	REF	REF	3-7	1A3A1R13
PH	5905-195-5514	RESISTOR, FXED, COMPOSITION RC20GF152K (81349)	EA	REF				REF	REF	REF	REF	REF	3-7	1A3A1R14
PH	5905-195-6451	RESISTOR, FIXED, COMPOSITION RC20GF472K (81349)	EA	1				REF	REF	REF	REF	REF	3-7	1A3A1R15
PH	5905-978-7113	RESISTOR, FIXED, FILM RN65B10R0F (81349)	EA	REF				REF	REF	REF	REF	REF	3-7	1A3A1R16
PH	5905-984-7685	RESISTOR, FIXED, FILM RN60B1500F (81349)	EA	1				*	*	2	8	3	3-7	1A3A1R17
PH	5905-833-3872	RESISTOR, FIXED, FILM RN60B1151F (81349)	EA	2				*	2	2	13	3	3-7	1A3A1R18
PH	5905-892-7005	RESISTOR, FIXED, FILM RN60B8250F (81349)	EA	1				*	*	2	8	3	3-7	1A3A1R19
PH		RESISTOR, FIXED, FILM RN60B1151F (81349)	EA	REF				REF	REF	REF	REF	REF	3-7	1A3A1R20
PH	5961-577-3022	TRANSISTOR JAN 2N220 (81349)	EA	3				REF	REF	REF	REF	REF	3-7	1A3A1Q1
PH	5961-577-3022	TRANSISTOR JAN 2N220 (81349)	EA	REF				REF	REF	REF	REF	REF	3-7	1A3A1Q2
PH	5961-577-3022	TRANSISTOR JAN 2N220 (81349)	EA	REF				REF	REF	REF	REF	REF	3-7	1A3A1Q3
PHS	6625-931-6814	POWER, AMPLIFIER, ASSEMBLY SMC380230 (80063)	EA	1				1	1	1	5	2	3-2	1A3A4
X2H	5950-470-1434	PIN, LOCK 002272 (02230)	EA	1										1A3A4MP1
X2H		NUT, PLAIN, HEXAGON MS35649-42 (96906)	EA	2										1A3A4MP1H2
X2H		SCREW MACHINE MS35223-17 (96906)	EA	2										1A3A4MP1H4
X2H		WASHER, FLAT MS27183-3 (96906)	EA	2										1A3A4MP1H6
X2H		WASHER, LOCK MS35335-15 (96906)	EA	2										1A3A4MP1H8
PH	5910-105-5476	CAPACITOR, FIXED, ELECTROLYTIC CL64CH080MP3 (81349)	EA	2				REF	REF	REF	REF	REF	3-10	1A3A4C1
PH	5910-105-5476	CAPACITOR, FIXED, ELECTROLYTIC CL64CH080MP3 (81349)	EA	REF				REF	REF	REF	REF	REF	3-10	1A3A4C2

SECTION II REPAIR PARTS FOR DIRECT SUPPORT, GENERAL SUPPORT, AND DEPOT MAINTENANCE (CONTINUED)

(1) SMR CODE	(2) FEDERAL STOCK NUMBER	(3) DESCRIPTION USABLE ON CODE REFER. NO. & MFR. CODE	(4) UNIT OF MEAS	(5) QTY INC IN UNIT	(6) 30-DAY DS MAINT ALLOWANCE			(7) 30-DAY GS MAINT ALLOWANCE			(8) 1 YR ALW PER EQUIP CNTGCT	(9) DEPOT MAINT ALW PER 100 EQUIP	(10) ILLUSTRATIONS	
					(a)	(b)	©	(a)	(b)	©			(a)	(b)
					1-20	21-50	51-100	1-20	21-50	51-100			FIG. NO.	ITEM NO. OR REFERENCE DESIGNATION
PH	5910-926-9786	CAPACITOR, FIXED, ELECTROLYTIC CS12BB157K (81349)	EA	REF				REF	REF	REF	REF	REF	3-10	1A3A4C3
PH	5910-104-1341	CAPACITOR, FIXED, ELECTROLYTIC CL64CH400MP3 (81349)	EA	2				REF	REF	REF	REF	REF	3-10	1A3A4C4
PH	5910-104-1341	CAPACITOR, FIXED, ELECTROLYTIC CL64CH400MP3 (81349)	EA	REF				REF	REF	REF	REF	REF	3-10	1A3A4C6
PH	5910-104-1339	CAPACITOR, FIXED, ELECTROLYTIC CL64CB300MP3 (81349)	EA	2				*	2	2	13	3	3-10	1A3A4C7
PH	5910-104-1339	CAPACITOR, FIXED, ELECTROLYTIC CL64CB300MP3 (81349)	EA	REF				REF	REF	REF	REF	REF	3-10	1A3A4C8
PH		CONNECTOR, PLUG, ELECTRICAL 212263 (02230)	EA	1				REF	REF	REF	REF	REF	3-10	1A3A4P1
X2H		NUT, PLAIN, HEXAGON MS35649-42 (96906)	EA	2										1A3A4P1MP1H2
X2H		SCREW MACHINE MS35223- 18 (96906)	EA	2										1A3A4P1MP1H4
X2H		WASHER, FLAT MS27183-3 (96906)	EA	2										1A3A4P1MP1H6
X2H		WASHER, LOCK MS35335-15 (96906)	EA	2										1A3A4P1MP1H8
PH		PRINTED, WIRING, BOARD 003062 (02230)	EA	1				*	*	2	8	3	3-10	1A3A4E1
PH	5905-188-8510	RESISTOR, FIXED, COMPOSITION RC20GF103K (81349)	EA	2				REF	REF	REF	REF	REF	3-10	1A3A4R1
PH	5905-198-4565	RESISTOR, FIXED, COMPOSITION RC20GF683K (81349)	EA	1				REF	REF	REF	REF	REF	3-10	1A3A4R2
PH	5905-195-6741	RESISTOR, FIXED, COMPOSITION RC20GF272K (81349)	EA	1				REF	REF	REF	REF	REF	3-10	1A3A4R3
PH	5905-185-8510	RESISTOR, FIXED, COMPOSITION RC20GF103K (81349)	EA	REF				REF	REF	REF	REF	REF	3-10	1A3A4R4
PH	5905-171-2006	RESISTOR, FIXED, COMPOSITION RC20GF271K (81349)	EA	1				*	*	2	8	3	3-10	1A3A4R5
PH	5901-190-8882	RESISTOR, FIXED, COMPOSITION RC20GF393K (81349)	EA	2				*	*	2	8	3	3-10	1A3A4R6
PH	5905-190-8882	RESISTOR, FIXED, COMPOSITION RC20GF393K (81349)	EA	REF				REF	REF	REF	REF	REF	3-10	1A3A4R7
PH	5905-195-6817	RESISTOR, FIXED, COMPOSITION RC20GF102K (81349)	EA	1				REF	REF	REF	REF	REF	3-10	1A3A4R8
PH	5905-279-2621	RESISTOR, FIXED, COMPOSITION RC20GF330K (81349)	EA	2				REF	REF	REF	REF	REF	3-10	1A3A4R9
PH	5909-279-2621	RESISTOR, FIXED, COMPOSITION RC20GF330K (81349)	EA	REF				REF	REF	REF	REF	REF	3-10	1A3A4R10
PH	5905-279-1876	RESISTOR, FIXED, COMPOSITION RC20GF222K (81349)	EA	1				REF	REF	REF	REF	REF	3-10	1A3A4R11
PH	5905-942-9326	RESISTOR, FIXED, COMPOSITION RC20GF561K (81349)	EA	1				*	*	2	8	3	3-10	1A3A4R12
PH	5905-190-8879	RESISTOR, FIXED, COMPOSITION RC20GF183K (81349)	EA	2				REF	REF	REF	REF	REF	3-10	1A3A4R13
PH	5905-190-8879	RESISTOR, FIXED, COMPOSITION RC20GF183K (81349)	EA	REF				REF	REF	REF	REF	REF	3-10	1A3A4R14

SECTION II REPAIR PARTS FOR DIRECT SUPPORT, GENERAL SUPPORT, AND DEPOT MAINTENANCE (CONTINUED)

(1) SMR CODE	(2) FEDERAL STOCK NUMBER	(3) DESCRIPTION USABLE ON CODE REFER. NO. & MFR. CODE	(4) UNIT OF MEAS	(5) QTY INC IN UNIT	(6) 30-DAY DS MAINT ALLOWANCE			(7) 30-DAY GS MAINT ALLOWANCE			(8) 1 YR ALW PER EQUIP CNTGCTY	(9) DEPOT MAINT ALW PER 100 EQUIP	(10) ILLUSTRATIONS	
					(a)	(b)	©	(a)	(b)	©			(a)	(b)
					1-20	21-50	51-100	1-20	21-50	51-100			FIG. NO.	ITEM NO. OR REFERENCE DESIGNATION
PH	5905-702-4397	RESISTOR, FIXED, WIRE WOUND RW59V4R0 (81349)	EA	2				*	2	2	13	3	3-10	1A3A4R15
PH	5905-702-4397	RESISTOR, FIXED, WIRE WOUND RW59V4R0 (81349)	EA	REF				REF	REF	REF	REF	REF	3-10	1A3A4R16
PH	5905-018-8887	RESISTOR, THERMAL KB22J6 (71368)	EA	3				*	2	2	18	3	3-10	1A3A4RT1
PH	5905-018-8887	RESISTOR THERMAL KB22J6 (71368)	EA	REF				REF	REF	REF	REF	REF	3-10	1A3A4RT2
PH	5905-018-8887	RESISTOR, THERMAL KB22J6 (71368)	EA	REF				REF	REF	REF	REF	REF	3-10	1A3A4RT3
PH	5950-470-1430	TRANSFORMER, AUDIO FREQUENCY 002162 (02230)	EA	1				*	*	2	8	3	3-10	1A3A4T1
PH	5950-470-1432	TRANSFORMER 002272 (02230)	EA	1				*	*	2	8	3	3-10	1A3A4T2
PH	5950-470-1431	TRANSFORMER 002282 (02230)	EA	1				*	*	2	8	3	3-10	1A3A4T3
PH	5961-752-0338	TRANSISTOR 2N43A (81349)	EA	3				REF	REF	REF	REF	REF	3-0	1A3A4Q1
PH	5961-752-0338	TRANSISTOR 2N43A (81349)	EA	REF				REF	REF	REF	REF	REF	3-10	1A3A4Q2
PH	5961-752-0338	TRANSISTOR 2N43A (81349)	EA	REF				REF	REF	REF	REF	REF	3-10	1A3A4Q3
PHS	6625-931-6805	RING, GENERATOR, ASSEMBLY SMC380234 (80063)	EA	1				1	1	1	5	2	3-2	1A3A8
X2H	5950-470-1432	PIN, LOCK 002272 (02230)	EA	1										1A3A8MP1
X2H		NUT, PLAIN, HEXAGON MS35649-42 (96906)	EA	2										1A3A8MP1H2
X2H		SCREW MACHINE MS35223-17 (96906)	EA	2										1A3A8MP1H4
X2H		WASHER, FLAT MS27183-3 (96906)	EA	2										1A3A8MP1H6
X2H		WASHER, LOCK MS35335-15 (96906)	EA	2										1A3A8MP1H8
PH		CONNECTOR, PLUG, ELECTRICAL 222343 (02230)	EA	1				*	*	2	8	3	3-14	1A3A8P1
X2H		NUT, PLAIN, HEXAGON MS35649-42 (96906)	EA	2										1A3A8P1MP1H2
X2H		SCREW MACHINE MS35223-18 (96906)	EA	2										1A3A8P1MP1H4
X2H		WASHER, FLAT MS2713-3 (96906)	EA	2										1A3A8P1MP1H6
X2H		WASHER, LOCK MS35335-15 (96906)	EA	2										1A3A8P1MP1H8
PH		PRINTED, WIRING, BOARD 003322 (02230)	EA	1				*	*	2	8	3	3-14	1A3A8E1
PH	5905-539-3982	RESISTOR FIXED, FILM RN65B1003F (81349)	EA	1				*	*	2	8	3	3-14	1A3A8R1
PH		RESISTOR, FIXED, WIRE WOUND RW57V122 (81349)	EA	1				*	*	2	8	3	3-14	1A3A8R2

SECTION II REPAIR PARTS FOR DIRECT SUPPORT, GENERAL SUPPORT, AND DEPOT MAINTENANCE (CONTINUED)

(1) SMR CODE	(2) FEDERAL STOCK NUMBER	(3) DESCRIPTION USABLE ON CODE REFER. NO. & MFR. CODE	(4) UNIT OF MEAS	(5) QTY INC IN UNIT	(6) 30-DAY DS MAINT ALLOWANCE			(7) 30-DAY GS MAINT ALLOWANCE			(8) 1 YR ALW PER EQUIP CNTGCT	(9) DEPOT MAINT ALW PER 100 EQUIP	(10) ILLUSTRATIONS	
					(a)	(b)	©	(a)	(b)	©			(a)	(b)
					1-20	21-50	51-100	1-20	21-50	51-100			FIG. NO.	ITEM NO. OR REFERENCE DESIGNATION
PH		RESISTOR, FIXED, WIRE WOUND RW57V282 (81349)	EA	1				*	*	2	8	3	3-14	1A3A8R3
PH	5905-681-8757	RESISTOR, FIXED, FILM RN60B3320F (81349)	EA	1				*	*	2	8	3	3-14	1A3A8R4
PH	5905-984-1463	RESISTOR, FIXED, FILM RN60B2210F (81349)	EA	1				*	*	2	8	3	3-14	11A3A8R5
PH	5905-050-1126	RESISTOR, FIXED, FILM RN70B3572F (81349)	EA	1				*	*	2	8	3	3-14	1A3A8R6
PH	5905-844-2258	RESISTOR, FIXED, WIRE WOUND RW57V152 (81349)	EA	1				*	*	2	8	3	3-14	1A3A8R7
PH	5905-978-9113	RESISTOR, FIXED, FILM RN65B10R0F (81349)	EA	1				*	*	2	8	3	3-14	1A3A8R8
PH	5905-963-5949	RESISTOR, FIXED, FILM RN60B9091F (81349)	EA	1				*	*	2	8	3	3-14	1A3A8R9
PH	5905-195-5534	RESISTOR, FIXED, COMPOSITION RC42GF182K (81349)	EA	1				*	*	2	8	3	3-14	1A3A8R10
PH	5905-646-5678	RESISTOR, FIXED, FILM RN60B1004F (81349)	EA	1				*	*	2	8	3	3-14	1A3A8R11
PH	5905-299-2037	RESISTOR, FIXED, COMPOSITION RC32GF472K (81349)	EA	1				*	*	2	8	3	3-14	1A3A8R12
PH	5905-577-6736	RESISTOR, FIXED, FILM RN60B1002F (81349)	EA	1				*	*	2	8	3	3-14	1A3A8R14
PH	5905-816-7484	RESISTOR, FIXED FILM RN60B4222F (81349)	EA	1				*	*	2	8	3	3-14	1A3A8R15
PH	5905-577-6735	RESISTOR, FIXED, FILM RN60B1212F (81349)	EA	1				*	*	2	8	3	3-14	1A3A8R16
PH	5905-951-9520	RESISTOR, FIXED, FILM RN65B6043F (81349)	EA	1				*	*	2	8	3	3-14	1A3A8R17
PH	5905-763-5280	RESISTOR, FIXED, FILM RN60B6040F (81349)	EA	1				*	*	2	8	3	3-14	1A3A8R18
PH	5905-552-7195	RESISTOR, FIXED, FILM RN70B2372F (81349)	EA	1				*	*	2	8	3	3-14	1A3A8R19
PH	5961-669-6884	SEMICONDUCTOR JAN IN277 (81349)	EA	4				REF	REF	REF	REF	REF	3-14	1A3A8CR1
PH	5961-669-6884	SEMICONDUCTOR JAN IN277 (81349)	EA	REF				REF	REF	REF	REF	REF	3-14	1A3APCR2
PH	5961-669-6884	SEMICONDUCTOR JAN IN277 (81349)	EA	REF				REF	REF	REF	REF	REF	3-14	1A3A8CR3
PH	5961-669-6884	SEMICONDUCTOR JAN IN277 (81349)	EA	REF				REF	REF	REF	REF	REF	3-14	1A3A8CR4
PHS	6625-931-6808	TRANSMISSION EFFICIENCY ASSEMBLY SMC380233 (80063)	EA	1				1	1	1	5	2	3-2	1A3A7
X2H	5950-470-1432	PIN, LOCK 002272 (02230)	EA	1									3-13	1A3A7MP1
X2H		NUT, PLAIN, HEXAGON MS35649-42 (96906)	EA	2										1A3A7MP1H2
X2H		SCREW MACHINE MS35223-17 (96906)	EA	2										1A3A7MP1H4
X2H		WASHER, FLAT MS27183-3 (96906)	EA	2										1A3A7MP1H6

SECTION II REPAIR PARTS FOR DIRECT SUPPORT, GENERAL SUPPORT, AND DEPOT MAINTENANCE (CONTINUED)

(1) SMR CODE	(2) FEDERAL STOCK NUMBER	(3) DESCRIPTION USABLE ON CODE REFER. NO. & MFR. CODE	(4) UNIT OF MEAS	(5) QTY INC IN UNIT	(6) 30-DAY DS MAINT ALLOWANCE			(7) 30-DAY GS MAINT ALLOWANCE			(8) 1 YR ALW PER EQUIP CNTGCT	(9) DEPOT MAINT ALW PER 100 EQUIP	(10) ILLUSTRATIONS	
					(a)	(b)	©	(a)	(b)	©			(a)	(b)
					1-20	21-50	51-100	1-20	21-50	51-100			FIG. NO.	ITEM NO. OR REFERENCE DESIGNATION
X2H		WASHER, LOCK MS35335-15 (96906)	EA	2										1A3A7MP1H8
PH	5910-823-1148	CAPACITOR, FIXED, PAPER DIELECTRIC CP04A1EB474K1 (81349)	EA	1				*	*	2	8	3	3-13	1A3A7C1
PH	5910-104-1341	CAPACITOR, FIXED, ELECTROLYTIC CL64CH400MP3 (81349)	EA	1				REF	REF	REF	REF	REF	3-13	1A3A7C2
PH		CONNECTOR, PLUG, ELECTRICAL 222343 (02230)	EA	1				REF	REF	REF	REF	REF	3-13	1A3A7P1
X2H		NUT, PLAIN, HEXAGON MS35649-42 (96906)	EA	2										1A3A7P1MP1H2
X2H		SCREW MACHINE MS35223-18 (96906)	EA	2										1A3A7P1MP1H4
X2H		WASHER, FLAT MS27183-3 (96906)	EA	2										1A3A7P1MP1H6
X2H		WASHER, LOCK MS35335-15 (96906)	EA	2										1A3A7P1MP1H8
PH		PRINTED WIRING BOARD 003072 (02230)	EA	1				*	*	2	8	3	3-13	1A3A7E1
PH	5905-552-6140	RESISTOR, FIXED, FILM RN70B60R4F (81349)	EA	1				*	*	2	8	3	3-13	1A3A7R1
PH	5905-722-1770	RESISTOR, FIXED, FILM RN60B5620F (81349)	EA	1				*	*	2	8	3	3-13	1A3A7R2
PH	5905-952-1755	RESISTOR, FIXED, FILM RN60B6190F (81349)	EA	2				*	2	2	13	3	3-13	1A3A7R3
PH	5905-061-3779	RESISTOR FIXED, FILM RN60B7150F (81349)	EA	2				*	2	2	13	3	3-13	1A3A7R4
PH	5905-078-7447	RESISTOR, FIXED, FILM RN60B3401F (81349)	EA	1				*	*	2	8	3	3-13	1A3A7R5
PH	5905-067-3779	RESISTOR FIXED, FILM RN60B7150F (81349)	EA	REF				REF	REF	REF	REF	REF	3-13	1A3A7R6
PH	5905-982-3337	RESISTOR FIXED, WIRE WOUND RW59V201 (81349)	EA	1				*	*	2	8	3	3-13	1A3A7R7
PH	5905-552-2438	RESISTOR FIXED, FILM RN75B1001F (81349)	EA	1				*	*	2	8	3	3-14	1A3A7R8
PH	5905-258-6558	RESISTOR, FIXED, COMPOSITION RC32GF470K (81349)	EA	1				*	*	*	5	3	3-13	1A3A7R9
PH	5905-089-2121	RESISTOR, FIXED, FILM RN60B1131F (81349)	EA	1				*	*	2	8	3	3-13	1A3A7R10
PH	5905-763-3615	RESISTOR, FIXED, FILM RN60B1620F (81349)	EA	1				*	*	2	8	3	3-13	1A3A7R11
PH	5905-681-8755	RESISTOR, FIXED, FILM RN60B8251F (81349)	EA	1				*	*	2	8	3	3-13	1A3A7R12
PH	5905-728-4810	RESISTOR, FIXED, FILM RN60B1102K (81349)	EA	1				*	*	2	8	3	3-13	1A3A7R13
PH		RESISTOR, FIXED, FILM RN60B6190F (81349)	EA	REF				REF	REF	REF	REF	REF	3-13	1A3A7R14
PH		RESISTOR, FIXED, FILM RN70C3000F (81349)	EA	1				*	*	2	8	3	3-13	1A3A7R15
PH	5950-470-1433	TRANSFORMER 002532 (02230)	EA	1				*	*	2	8	3	3-13	1A3A7T1

SECTION II REPAIR PARTS FOR DIRECT SUPPORT, GENERAL SUPPORT, AND DEPOT MAINTENANCE (CONTINUED)

(1) SMR CODE	(2) FEDERAL STOCK NUMBER	(3) DESCRIPTION USABLE ON CODE REFER. NO. & MFR. CODE	(4) UNIT OF MEAS	(5) QTY INC IN UNIT	(6) 30-DAY DS MAINT ALLOWANCE			(7) 30-DAY GS MAINT ALLOWANCE			(8) 1 YR ALW PER EQUIP CNTGCTY	(9) DEPOT MAINT ALW PER 100 EQUIP	(10) ILLUSTRATIONS	
					(a)	(b)	©	(a)	(b)	©			(a)	(b)
					1-20	21-50	51-100	1-20	21-50	51-100			FIG. NO.	ITEM NO. OR REFERENCE DESIGNATION
X2H		CHASSIS, ELECTRICAL, EQUIPMENT 001834 (02230)	EA	1								1-1	1A3	
X2H		CLAMP LOOP 161774 (02230)	EA	2									1A3MP1	
X2H		NUT, PLAIN, HEXAGON MS35649-62 (96906)	EA	1									1A3MP1H1	
X2H		SCREW MACHINE MS35225-31 (96906)	EA	1									1A3MP1H2	
X2H		WASHER, FLAT MS27183-6 (96906)	EA	1									1A3MP1H3	
X2H		WASHER, LOCK MS35338-41 (96906)	EA	1									1A3MP1H4	
X2H		CLAMP LOOP 161774 (02230)	EA	REF									1A3MP2	
X2H		NUT, PLAIN, HEXAGON MS35649-62 (96906)	EA	1									1A3MP2H1	
X2H		SCREW MACHINE MS35225-31 (96906)	EA	1									1A3MP2H2	
X2H		WASHER, FLAT MS27183-6 (96906)	EA	1									1A3MP2H3	
X2H		WASHER, LOCK MS35338-41 (96906)	EA	1									1A3MP2H4	
X2H		CLAMP LOOP 171774 (02230)	EA	2									1A3MP3	
X2H		NUT, PLAIN, HEXAGON MS35649-62 (96906)	EA	1									1A3MP3H1	
X2H		SCREW MACHINE MS35225-31 (96906)	EA	1									1A3MP3H2	
X2H		WASHER, FLAT MS27183-6 (96906)	EA	1									1A3MP3H3	
X2H		WASHER, LOCK MS35338-41 (96906)	EA	1									1A3MP3H4	
X2H		CLAMP LOOP 171774 (02230)	EA	REF									1A3MP4	
X2H		NUT, PLAIN, HEXAGON MS35649-62 (96906)	EA	1									1A3MP4H1	
X2H		SCREW MACHINE MS35225-31 (96906)	EA	1									1A3MP4H2	
X2H		WASHER, FLAT MS27183-6 (96906)	EA	1									1A3MP4H3	
X2H		WASHER, LOCK MS35338-41 (96906)	EA	1									1A3MP4H4	
X2H		CLAMP LOOP 201774 (02230)	EA	2									1A3MP5	
X2H		NUT, PLAIN, HEXAGON MS35649-62 (9696)	EA	1									1A3MP5H1	
X2H		SCREW MACHINE MS35225-31 (96906)	EA	1									1A3MP5H2	
X2H		WASHER, FLAT MS27183-6 (96906)	EA	1									1A3MP5H3	

SECTION II REPAIR PARTS FOR DIRECT SUPPORT, GENERAL SUPPORT, AND DEPOT MAINTENANCE (CONTINUED)

(1) SMR CODE	(2) FEDERAL STOCK NUMBER	(3) DESCRIPTION USABLE ON CODE REFER. NO. & MFR. CODE	(4) UNIT OF MEAS	(5) QTY INC IN UNIT	(6) 30-DAY DS MAINT ALLOWANCE			(7) 30-DAY GS MAINT ALLOWANCE			(8) 1 YR ALW PER EQUIP CNTGCT	(9) DEPOT MAINT ALW PER 100 EQUIP	(10) ILLUSTRATIONS	
					(a)	(b)	©	(a)	(b)	©			(a)	(b)
					1-20	21-50	51-100	1-20	21-50	51-100			FIG. NO.	ITEM NO. OR REFERENCE DESIGNATION
X2H		WASHER, LOCK MS35338-41 (96906)	EA	1										1A3MP5H4
X2H		CLAMP LOOP 201774 (02230)	EA	REF										1A3MP6
X2H		NUT, PLAIN, HEXAGON MS35649-62 (96906)	EA	1										1A3MP6H1
X2H	5305-754-4343	SCREW MACHINE MS35239-34 (96906)	EA	1										1A3MP6H2
X2H		WASHER, FLAT MS27183-6 (96906)	EA	1										1A3MP6H3
X2H		WASHER, LOCK MS35338-41 (96906)	EA	1										1A3MP6H4
X2H		CLAMP LOOP 201774 (02230)	EA	2										1A3MP7
X2H		NUT, PLAIN, HEXAGON MS35649-62 (96906)	EA	1										1A3MP7H1
X2H		SCREW MACHINE MS35239-34 (96906)	EA	1										1A3MP7H2
X2H		WASHER, FLAT MS27183-6 (96906)	EA	1										1A3MP7H3
X2H		WASHER, LOCK MS35338-41 (96906)	EA	1										1A3MP7H4
X2H		CLAMP LOOP 201774 (02230)	EA	REF										1A3MP8
X2H		NUT, PLAIN, HEXAGON MS35649-62 (96906)	EA	1										1A3MP8H1
X2H		SCREW MACHINE MS35239-34 (96906)	EA	1										1A3MP8H2
X2H		WASHER, FLAT MS27183-6 (96906)	EA	1										1A3MP8H3
X2H		WASHER, LOCK MS35338-41 (96906)	EA	1										1A3MP8H4
PH		CONNECTOR, RECEPTICAL, ELECTRICAL 091774 (02230)	EA	8				*	2	2	27	3	3-3	1A3J1
X2H		CLAMP LOOP 161774 (02230)	EA	1										1A3J1MP1
X2H		NUT, PLAIN, HEXAGON MS35649-62 (96906)	EA	2										1A3J1MP1H2
X2H		SCREW MACHINE MS35225-31 (96906)	EA	2										1A3J1MP1H4
X2H		WASHER, FLAT MS27183-6 (96906)	EA	2										1A3J1MP1H6
X2H		WASHER, LOCK MS35338-41 (96906)	EA	2										1A3J1MP1H8
PH		CONNECTOR, RECEPTICAL, ELECTRICAL 091774 (02230)	EA	REF				REF	REF	REF	REF	REF	3-3	1A3J2
X2H		NUT, PLAIN, HEXAGON MS35649-62 (96906)	EA	2										1A3J2MP1H2
X2H		SCREW MACHINE MS35225-31 (96906)	EA	2										1A3J2MP1H4

SECTION II REPAIR PARTS FOR DIRECT SUPPORT, GENERAL SUPPORT, AND DEPOT MAINTENANCE (CONTINUED)

(1) SMR CODE	(2) FEDERAL STOCK NUMBER	(3) DESCRIPTION USABLE ON CODE REFER. NO. & MFR. CODE	(4) UNIT OF MEAS	(5) QTY INC IN UNIT	(6) 30-DAY DS MAINT ALLOWANCE			(7) 30-DAY GS MAINT ALLOWANCE			(8) 1 YR ALW PER EQUIP CNTGCTY	(9) DEPOT MAINT ALW PER 100 EQUIP	(10) ILLUSTRATIONS	
					(a)	(b)	©	(a)	(b)	©			(a)	(b)
					1-20	21-50	51-100	1-20	21-50	51-100			FIG. NO.	ITEM NO. OR REFERENCE DESIGNATION
X2H		WASHER, FLAT MS27183-6 (96906)	EA	2										1A3J2MP1H6
X2H		WASHER, LOCK MS35338-41 (96906)	EA	2										1A3J2MP1H8
PH		CONNECTOR, RECEPTICAL, ELECTRICAL 091774 (02230)	EA	REF				REF	REF	REF	REF	REF	3-3	1A3J3
X2H		NUT, PLAIN, HEXAGON MS35649-62 (96906)	EA	2										1A3J3MP1H2
X2H		SCREW MACHINE MS35225-31 (96906)	EA	2										1A3J3MP1H4
X2H		WASHER, FLAT MS27183-6 (96906)	EA	2										1A3J3MP1H6
X2H		WASHER, LOCK MS35338-41 (96906)	EA	2										1A3J3MP1H8
PH		CONNECTOR, RECEPTICAL, ELECTRICAL 091774 (02230)	EA	REF				REF	REF	REF	REF	REF	3-3	1A3J4
X2H		NUT, PLAIN, HEXAGON MS35649-62 (96906)	EA	2										1A3J4MP1H2
X2H		SCREW MACHINE MS35225-31 (96906)	EA	2										1A3J4MP1H4
X2H		WASHER, FLAT MS27183-6 (96906)	EA	2										1A3J4MP1H6
X2H		WASHER, LOCK MS35338-41 (96906)	EA	2										1A3J4MP1H8
PH		CONNECTOR, RECEPTICAL, ELECTRICAL 091774 (02230)	EA	REF				REF	REF	REF	REF	REF	3-3	1A3J5
X2H		CLAMP LOOP 161774 (02230)	EA	1										1A3J5MP1
X2H		NUT, PLAIN, HEXAGON MS35649-62 (96906)	EA	2										1A3J5MP1H2
X2H		SCREW MACHINE MS35225-31 (96906)	EA	2										1A3J5MP1H4
X2H		WASHER, FLAT MS27183-6 (96906)	EA	2										1A3J5MP1H6
X2H		WASHER, LOCK MS35338-41 (96906)	EA	2										1A3J5MP1H8
PH		CONNECTOR, RECEPTICAL, ELECTRICAL 091774 (02230)	EA	REF				REF	REF	REF	REF	REF	3-3	1A3J6
X2H		NUT, PLAIN, HEXAGON MS35649-62 (96906)	EA	2										1A3J6MP1H2
X2H		SCREW MACHINE MS35225-31 (96906)	EA	2										1A3J6MP1H4
X2H		WASHER, FLAT MS27183-6 (96906)	EA	2										1A3J6MP1H6
X2H		WASHER, LOCK MS35338-41 (96906)	EA	2										1A3J6MP1H8
PH		CONNECTOR RECEPTICAL ELECTRICAL 081774 (02230)	EA	2				*	*	2	13	3	3-3	1A3J7
X2H		CLAMP LOOP 161774 (02230)	EA	1										1A37MP1

SECTION II REPAIR PARTS FOR DIRECT SUPPORT, GENERAL SUPPORT, AND DEPOT MAINTENANCE (CONTINUED)

(1) SMR CODE	(2) FEDERAL STOCK NUMBER	(3) DESCRIPTION USABLE ON CODE REFER. NO. & MFR. CODE	(4) UNIT OF MEAS	(5) QTY INC IN UNIT	(6) 30-DAY DS MAINT ALLOWANCE			(7) 30-DAY GS MAINT ALLOWANCE			(8) 1 YR ALW PER EQUIP CNTGCT	(9) DEPOT MAINT ALW PER 100 EQUIP	(10) ILLUSTRATIONS	
					(a)	(b)	©	(a)	(b)	©			(a)	(b)
					1-20	21-50	51-100	1-20	21-50	51-100			FIG. NO.	ITEM NO. OR REFERENCE DESIGNATION
X2H		NUT, PLAIN, HEXAGON MS35649-62 (96906)	EA	2										1A3J7MP1H2
X2H		SCREW MACHINE MS35225-31 (96906)	EA	2										1A3J7MP1H4
X2H		WASHER, FLAT MS27183-6 (96906)	EA	2										1A3J7MP1H6
X2H		WASHER, LOCK MS35338-41 (96906)	EA	2										1A3J7MP1H8
PH		CONNECTOR, RECEPTAL, ELECTRICAL (02230)	EA	REF				REF	REF	REF	REF	REF	3-3	1A3J8
X2H		NUT, PLAIN, HEXAGON MS35649-62 (96906)	EA	2										1A3J8MP1H2
X2H		SCREW MACHINE MS35225-31 (96906)	EA	2										1A3J8MP1H4
X2H		WASHER, FLAT MS27183-6 (96906)	EA	2										1A3J8MP1H6
X2H		WASHER, LOCK MS35338-41 (96906)	EA	1										1A3J8MP1H8
PH		CONNECTOR, RECEPTAL, ELECTRICAL (02230)	EA	REF				REF	REF	REF	REF	REF	3-3	1A3J9
X2H		CLAMP LOOP (02230)	EA	1										1A3J9MP1
X2H		NUT, PLAIN, HEXAGON MS35649-62 (96906)	EA	2										1A3J9MP1H2
X2H		SCREW MACHINE MS35225-31 (96906)	EA	2										1A3J9MP1H4
X2H		WASHER, FLAT MS27183-6 (96906)	EA	2										1A3J9MP1H6
X2H		WASHER, LOCK MS35338-41 (96906)	EA	2										1A3J9MP1H8
PH		CONNECTOR, RECEPTAL, ELECTRICAL (02230)	EA	REF				REF	REF	REF	REF	REF	3-3	1A3J10
X2H		NUT, PLAIN, HEXAGON MS35649-62 (96906)	EA	2										1A3J10MP1H2
X2H		SCREW MACHINE MS35225-31 (96906)	EA	2										1A3J10MP1H4
X2H		WASHER, FLAT MS27183-6 (96906)	EA	2										1A3J10MP1H6
X2H		WASHER, LOCK MS35338-41 (96906)	EA	2										1A3J10MP1H8
PH	5915-931-6832	FILTER, BAND PASS SMB380193 (80063)	EA	1				*	*	*	5	3	3-2	1A3FL1
X2H	5305-043-6664	SCREW MACHINE MS35225-29 (96906)	EA	4										1A3FL1MP1H4
X2H		WASHER, LOCK MS35338-41 (96906)	EA	4										1A3FL1MP1H8
PH	5915-931-6835	FILTER, BAND PASS SMB380194 (80063)	EA	1				*	*	*	5	3	3-2	1A3FL2
X2H		SCREW MACHINE MS35225-29 (96906)	EA	4										1A3FL2MP1H4

SECTION II REPAIR PARTS FOR DIRECT SUPPORT, GENERAL SUPPORT, AND DEPOT MAINTENANCE (CONTINUED)

(1) SMR CODE	(2) FEDERAL STOCK NUMBER	(3) DESCRIPTION USABLE ON CODE REFER. NO. & MFR. CODE	(4) UNIT OF MEAS	(5) QTY INC IN UNIT	(6) 30-DAY DS MAINT ALLOWANCE			(7) 30-DAY GS MAINT ALLOWANCE			(8) 1 YR ALW PER EQUIP CNTGCTY	(9) DEPOT MAINT ALW PER 100 EQUIP	(10) ILLUSTRATIONS	
					(a)	(b)	©	(a)	(b)	©			(a)	(b)
					1-20	21-50	51-100	1-20	21-50	51-100			FIG. NO.	ITEM NO. OR REFERENCE DESIGNATION
X2H		WASHER, LOCK MS35338-41 (96906)	EA	4										1A3FL2MP1H8
PH	5915-931-6834	FILTER, BAND PASS SMB380195 (80063)	EA	1				*	*	*	5	3	3-2	1A3FL3
X2H		SCREW MACHINE MS35225-29 (96906)	EA	4										1A3FL3MP1H4
X2H		WASHER, LOCK MS35338-41 (96906)	EA	4										1A3FL3MP1H8
PH	5915-931-6833	FILTER, BAND PASS SMB380196 (80063)	EA	1				*	*	*	5	3	3-2	1A3FL4
X2H		SCREW MACHINE MS35225-29 (96906)	EA	4										1A3FL4MP1H4
X2H		WASHER, LOCK MS35338-41 (96906)	EA	4										1A3FL4MP1H8
PC		FUSE, CARTRIDGE 101774 (02230)	EA	1				2	2	3	130	50	3-3	1A3F1
PH		FUSEHOLDER 111774 (02230)	EA	1				*	*	2	8	3		1A3XF1
X2H		NUT, PLAIN, HEXAGON MS35649-62 (96906)	EA	2										1A3XF1MP1H2
X2H		SCREW MACHINE MS35225-29 (96906)	EA	2										1A3XF1MP1H4
X2H		WASHER, LOCK MS35338-41 (96906)	EA	2										1A3XF1MP1H6
PH	5325-174-5317	GROMMET, RUBBER MS35489-4 (96906)	EA	2				2	2	2	33	8		1A3MP1
PH	5325-276-6228	GROMMET, RUBBER MS35489-9 (96906)	EA	1				*	2	2	19	4		1A3MP2
PH	5325-185-0017	GROMMET, RUBBER MS35489-33 (96906)	EA	1				*	2	2	19	4		1A3MP3
PH	5325-285-8363	GROMMET, RUBBER MS35489-45 (96906)	EA	1				*	2	2	19	4		1A3MP4
PH	5325-174-5351	GROMMET, RUBBER MS35489-4 (96906)	EA	REF				REF	REF	REF	REF	REF		1A3MP5
PH	5325-276-5954	GROMMET, RUBBER MS35489-49 (96906)	EA	1				*	2	2	19	4		1A3MP6
X2H		INSULATOR, STANDOFF SMD380177 (02230)	EA	5										1A3E1
X2H		SCREW MACHINE MS35225-13 (96906)	EA	1										1A3E1MP1H1
X2H		INSULATOR, STANDOFF 071774 (02230)	EA	REF										1A3E2
X2H		SCREW MACHINE MS35225-13 (96906)	EA	1										1A3E2MP1H1
X2H		INSULATOR, STANDOFF 071774 (02230)	EA	REF										1A3E3
X2H		SCREW MACHINE MS35225-13 (96906)	EA	1										1A3E3MP1H1
X2H		INSULATOR, STANDOFF 071774 (02230)	EA	REF										1A3E4

SECTION II REPAIR PARTS FOR DIRECT SUPPORT, GENERAL SUPPORT, AND DEPOT MAINTENANCE (CONTINUED)

(1) SMR CODE	(2) FEDERAL STOCK NUMBER	(3) DESCRIPTION USABLE ON CODE REFER. NO. & MFR. CODE	(4) UNIT OF MEAS	(5) QTY INC IN UNIT	(6) 30-DAY DS MAINT ALLOWANCE			(7) 30-DAY GS MAINT ALLOWANCE			(8) 1 YR ALW PER EQUIP CNTGCTY	(9) DEPOT MAINT ALW PER 100 EQUIP	(10) ILLUSTRATIONS	
					(a)	(b)	©	(a)	(b)	©			(a)	(b)
					1-20	21-50	51-100	1-20	21-50	51-100			FIG. NO.	ITEM NO. OR REFERENCE DESIGNATION
X2H		SCREW MACHINE MS35225-13 (96906)	EA	1										1A3E4MP1H1
X2H		INSULATOR, STANDOFF 071774 (02230)	EA	REF										1A3E5
X2H		SCREW MACHINE MS35225-13 (96906)	EA	1										1A3E5MP1H1
PC	5805-244-1915	GENERATOR, RINGING, STATIC SC-DL-98460 (80063)	EA	1				*	*	2	5	3	3-2	1A3A11
PH		GROMMET, RUBBER 003222 (02230)	EA	4				2	2	2	59	12		1A3A11MP1
PH		GROMMET, RUBBER 003222 (02230)	EA	REF				REF	REF	REF	REF	REF		1A3A11MP2
PH		GROMMET, RUBBER 003222 (02230)	EA	REF				REF	REF	REF	REF	REF		1A3A11MP3
PH		GROMMET, RUBBER 003222 (02230)	EA	REF				REF	REF	REF	REF	REF		1A3A11MP4
PH	5325-582-3601	GROMMET, RUBBER MS35489-38 (96906)	EA	4				2	2	2	59	12		1A3A11MP8
X2H	5305-043-6639	SCREW MACHINE MS35225-14 (96906)	EA	4										1A3A11MP1H4
MD		SPACER, SLEEVE 002462 (02230)	EA	4										1A3A11MP9
MD		SPACER, SLEEVE 002462 (02230)	EA	REF										1A3A11MP10
MD		SPACER, SLEEVE 002462 (02230)	EA	REF										1A3A11MP11
MD		SPACER, SLEEVE 002462 (02230)	EA	REF										1A3A11MP12
X2H		WASHER, FLAT 003362 (02230)	EA	4										1A3A11MP13
X2H		WASHER, FLAT 003362 (02230)	EA	REF										1A3A11MP14
X2H		WASHER, FLAT 003362 (02230)	EA	REF										1A3A11MP15
X2H		WASHER, FLAT 003362 (02230)	EA	REF										1A3A11MP16
X2H		WASHER, FLAT 003372 (02230)	EA	4										1A3A11MP17I
X2H		WASHER, FLAT 003372 (02230)	EA	REF										1A3A11MP18
X2H		WASHER, FLAT 003372 (02230)	EA	REF										1A3A11MP19
X2H		WASHER, FLAT 003372 (02230)	EA	REF										1A3A11MP20
X2H	5310-950-1310	WASHER, FLAT MS27183-4 (96906)	EA	4										1A3A11MP1H8
X2H		WASHER, LOCK MS35338-40 (96906)	EA	4										1A3A11MP1H12
X2H		PIN, LOCK 002962 (02230)	EA	2										1A3MP1

SECTION II REPAIR PARTS FOR DIRECT SUPPORT, GENERAL SUPPORT, AND DEPOT MAINTENANCE (CONTINUED)

(1) SMR CODE	(2) FEDERAL STOCK NUMBER	(3) DESCRIPTION USABLE ON CODE REFER. NO. & MFR. CODE	(4) UNIT OF MEAS	(5) QTY INC IN UNIT	(6) 30-DAY DS MAINT ALLOWANCE			(7) 30-DAY GS MAINT ALLOWANCE			(8) 1 YR ALW PER EQUIP CNTGCT	(9) DEPOT MAINT ALW PER 100 EQUIP	(10) ILLUSTRATIONS	
					(a)	(b)	©	(a)	(b)	©			(a)	(b)
					1-20	21-50	51-100	1-20	21-50	51-100			FIG. NO.	ITEM NO. OR REFERENCE DESIGNATION
X2H	5305-043-6637	SCREW MACHINE MS35225-12 (96906)	EA	1										1A3MP1H1
X2H		WASHER, FLAT MS27183-4 (96906)	EA	1										1A3MP1H2
X2H		WASHER, LOCK MS35338-40 (96906)	EA	1										1A3MP1H3
X2H		PIN, LOCK 002962 (02230)	EA	REF										1A3MP2
X2H		SCREW MACHINE MS35225-12 (96906)	EA	1										1A3MP2H1
X2H		WASHER, FLAT MS27183-4 (96906)	EA	1										1A3MP2H2
X2H		WASHER, LOCK MS35338-40 (96906)	EA	1										1A3MP2H3
PH	5950-470-1435	REACTOR 003462 (02230)	EA	1				*	*	2	8	2	3-2	1A3L1
X2H		NUT, PLAIN HEXAGON MS35649-62 (96906)	EA	2										1A3AL1MP1H2
X2H		WASHER, LOCK MS35338-41 (96906)	EA	2										1A3AL1MP1H4
PH	5961-951-6301	SEMICONDUCTOR, DEVICE DIODE IN2989RB (81349)	EA	1				*	*	2	8	3	3-2	1A3CR1
PH	5961-843-5177	SEMICONDUCTOR, DEVICE DIODE IN2986B (81349)	EA	1				*	*	2	8	8	3-2	1A3CR2
PH	5950-470-1434	TRANSFORMER ,POWER, STEP-UP 003433 (02230)	EA	1				*	*	2	8	3	3-2	1A3T1
X2H	5310-012-0622	NUT, PLAIN, HEXAGON MS35649-82 (96906)	EA	4										1A3T1MP1H4
MD		PLATE, MOUNTING, TRANSFORMER 002192 (02230)	EA	1										1A3T1MP1
X2H		WASHER, LOCK MS35338-42 (96906)	EA	4										1A3T1MP1H8
PH	5961-821-8976	TRANSISTOR 2N297A (81349)	EA	1				*	*	2	8	3	3-2	1A3Q1
PH	5905-702-6278	RESISTOR, VARIABLE RA20LASB500A (81349)	EA	2				*	2	2	12	6	3-2	1A3R11
PH		RESISTOR, VARIABLE RA20LASB203A (81349)	EA	1				*	2	2	12	3	3-2	1A3R15
PH	5905-814-4987	RESISTOR, VARIABLE RA20LASB501A (81349)	EA	1				*	2	2	12	3	3-2	1A3R16
PH	5905-702-6278	RESISTOR, VARIABLE RA20LASB500A (81349)	EA	REF				REF	REF	REF	REF	REF	3-2	1A3R9
AHR		PANEL CHASSS ASSEMBLY 002424 (02230)	EA	1									1-1	1A4
PH	5340-469-8367	CATCH, CLAMPING 162424 (02230)	EA	3				*	*	2	18	9		1A4MP1
X2H		FASTENER S-632-2 (46384)	EA	2										1A4MP1H2
X2H		SCREW MACHINE MS-35225-29 (96906)	EA	2										1A4MP1H4

SECTION II REPAIR PARTS FOR DIRECT SUPPORT, GENERAL SUPPORT, AND DEPOT MAINTENANCE (CONTINUED)

(1) SMR CODE	(2) FEDERAL STOCK NUMBER	(3) DESCRIPTION USABLE ON CODE REFER. NO. & MFR. CODE	(4) UNIT OF MEAS	(5) QTY INC IN UNIT	(6) 30-DAY DS MAINT ALLOWANCE			(7) 30-DAY GS MAINT ALLOWANCE			(8) 1 YR ALW PER EQUIP CNTGCT	(9) DEPOT MAINT ALW PER 100 EQUIP	(10) ILLUSTRATIONS	
					(a)	(b)	©	(a)	(b)	©			(a)	(b)
					1-20	21-50	51-100	1-20	21-50	51-100			FIG. NO.	ITEM NO. OR REFERENCE DESIGNATION
X2H		WASHER, LOCK MS35338-41 (96906)	EA	2										1A4MP1H6
PH	5340-469-8367	CATCH, CLAMPING 162424 (02230)	EA	REF				REF	REF	REF	REF	REF		1A4MP2
X2H		FASTENER S-632-2 (46384)	EA	2										1A4MP2H2
X2H		SCREW MACHINE MS35225-29 (96906)	EA	2										1A4MP2H4
X2H		WASHER, LOCK MS35338-41 (96906)	EA	2										1A4MP2H6
PH	5340-469-8367	CATCH, CLAMPING 162424 (02230)	EA	REF				REF	REF	REF	REF	REF		1A4MP3
X2H		FASTENER S-632-2 (46384)	EA	2										1A4MP3H2
X2H		SCREW MACHINE MS35225-29 (96906)	EA	2										1A4MP3H4
X2H		WASHER, LOCK MS35338-41 (96906)	EA	2										1A4MP3H6
PH		HINGE, BUTT 002153 (02230)	EA	1				*	*	2	8	3	13	1A4MP4
X2H	5310-012-0614	NUT, PLAIN, HEXAGON MS35650-102 (96906)	EA	6										1A4MP4H6
X2H	5305-043-6746	SCREW MACHINE MS35226-59 (96906)	EA	6										1A4MP4H12
X2H		WASHER, LOCK MS35338-41 (96906)	EA	6										1A4MP4H18
PH	5305-409-6886	SCREW, CAPTIVE 002472 (02230)	EA	6				*	2	2	33	12		1A4MP5
PH		ATTENUATOR, VARIABLE 222424 (02230)	EA	1				*	*	2	8	5	3-5	1A4AT1
X2H	5305-754-4343	SCREW MACHINE MS35239-34 (96906)	EA	4										1A4AT3MP1H4
PH		ATTENUATOR, VARIABLE 232424 (02230)	EA	1				*	*	2	8	5	3-5	1A4AT2
X2H		SCREW MACHINE MS35239-34 (96906)	EA	4										1A4AT2MP1H4
PH		ATTENUATOR, VARIABLE 232424 (02230)	EA	1				*	*	2	8	5	3-5	1A4AT3
X2H		SCREW MACHINE MS35239-34 (96906)	EA	4										1A4AT3MP1H4
PH		ATTENUATOR, VARIABLE 242424 (02230)	EA	1				*	*	2	8	5	3-5	1A4AT4
X2H		SCREW MACHINE MS35239-34 (96906)	EA	4										1A4AT4MP1H4
MD		BRACE, CORNER 002972 (02230)	EA	1										1A4MP6
X2H		NUT, PLAIN, HEXAGON MS35649-82 (96906)	EA	8										1A4MP6H8
X2H	5305-290-2066	SCREW MACHINE MS35241-52 (96906)	EA	4										1A4MP6H12

SECTION II REPAIR PARTS FOR DIRECT SUPPORT, GENERAL SUPPORT, AND DEPOT MAINTENANCE (CONTINUED)

(1) SMR CODE	(2) FEDERAL STOCK NUMBER	(3) DESCRIPTION USABLE ON CODE REFER. NO. & MFR. CODE	(4) UNIT OF MEAS	(5) QTY INC IN UNIT	(6) 30-DAY DS MAINT ALLOWANCE			(7) 30-DAY GS MAINT ALLOWANCE			(8) 1 YR ALW PER EQUIP CNTGCTY	(9) DEPOT MAINT ALW PER 100 EQUIP	(10) ILLUSTRATIONS	
					(a)	(b)	©	(a)	(b)	©			(a)	(b)
					1-20	21-50	51-100	1-20	21-50	51-100			FIG. NO.	ITEM NO. OR REFERENCE DESIGNATION
X2H		SCREW MACHINE MS35225-30 (96906)	EA	4										1A4MP6H16
MD		BRACKET 002602 (02230)	EA	2										1A4MP6MP1
MD		BRACKET 002602 (02230)	EA	REF										1A4MP6MP2
X2H		WASHER, LOCK MS35338-42 (96906)	EA	4										1A4MP6H20
PH		BUSHING, STRAIN, RELIEF 102424 (02230)	EA	2				*	*	*	5	3		1A4MP7
PH		BUSHING, STRAIN, RELIEF 102424 (02230)	EA	REF				REF	REF	REF	REF	REF		1A4MP8
PH		BUSHING, STRAIN, RELIEF 112424 (02230)	EA	1				*	*	*	4	2		1A4MP9
PH		CABLE, SPECIAL PURPOSE ELECTRICAL 082424 (02230)	EA	2				*	2	2	13	20	1-1	1A4W1
PHR		CABLE, AUDIO, SPECIAL PURPOSE ELECTRICAL 082424 (02230)	EA	REF				REF	REF	REF	REF	REF	1-1	1A4W2
PH		CABLE, ASSEMBLY, POWER ELECTRICAL 003492 (02230)	EA	1				*	*	2	8	4	1-1	1A4W3
X2H		CONNECTOR, PLUG, ELECTRICAL 023492 (02230)	EA	1				*	*	2	8	4	1-1	1A4W3P1
X2H		CLAMP, LOOP 322424 (02230)	EA	1										1A4MP10
X2H		NUT, PLAIN, HEXAGON MS3649-62 (96906)	EA	1										1A4MP10H1
X2H		SCREW MACHINE MS35239-34 (96906)	EA	1										1A4MP10H2
X2H		WASHER, FLAT MS27183-6 (96906)	EA	1										1A4MP10H3
X2H		WASHER, LOCK MS35338-41 (96906)	EA	1										1A4MP10H4
X2H		CLAMP, LOOP 312424 (02230)	EA	1										1A4MP11
X2H		NUT, PLAIN, HEXAGON MS35649-62 (96906)	EA	1										1A4MP11H1
X2H		SCREW MACHINE MS35239-34 (96906)	EA	1										1A4MP11H2
X2H		WASHER, FLAT MS27183-6 (96906)	EA	1										1A4MP11H3
X2H		WASHER, LOCK MS35338-41 (96906)	EA	1										1A4MP11H4
X2H		CLAMP, LOOP 322424 (02230)	EA	2										1A4MP12
X2H		NUT, PLAIN, HEXAGON MS35649-62 (96906)	EA	1										1A4MP12H1
X2H	5305-013-3436	SCREW MACHINE MS35241-38 (96906)	EA	1										1A4MP12H2
X2H		WASHER, FLAT MS27183-6 (96906)	EA	1										1A4MP12H3

SECTION II REPAIR PARTS FOR DIRECT SUPPORT, GENERAL SUPPORT, AND DEPOT MAINTENANCE (CONTINUED)

(1) SMR CODE	(2) FEDERAL STOCK NUMBER	(3) DESCRIPTION USABLE ON CODE REFER. NO. & MFR. CODE	(4) UNIT OF MEAS	(5) QTY INC IN UNIT	(6) 30-DAY DS MAINT ALLOWANCE			(7) 30-DAY GS MAINT ALLOWANCE			(8) 1 YR ALW PER EQUIP CNTGCTY	(9) DEPOT MAINT ALW PER 100 EQUIP	(10) ILLUSTRATIONS	
					(a)	(b)	©	(a)	(b)	©			(a)	(b)
					1-20	21-50	51-100	1-20	21-50	51-100			FIG. NO.	ITEM NO. OR REFERENCE DESIGNATION
X2H		WASHER, LOCK MS35338-41 (96906)	EA	1									1A4MP12H4	
X2H		CLAMP, LOOP 312424 (02230)	EA	REF									1A4MP13	
X2H		NUT, PLAIN, HEXAGON MS35649-6 (96906)	EA	1									1A4MP13H1	
X2H		SCREW MACHINE MS35241-38 (96906)	EA	1									1A4MP13H2	
X2H		WASHER, FLAT MS27183-6 (96906)	EA	1									1A4MP13H3	
X2H		WASHER, LOCK MS35338-41 (96906)	EA	1									1A4MP13H4	
X2H		CLAMP, LOOP 322424 (02230)	EA	2									1A4MP14	
X2H		NUT, PLAIN, HEXAGON MS35649-62 (96906)	EA	1									1A4MP14H1	
X2H		SCREW MACHINE MS35241-38 (96906)	EA	1									1A4MP14H2	
X2H		WASHER, FLAT MS27183-6 (96906)	EA	1									1A4MP14H3	
X2H		WASHER, LOCK MS35338-41 (96906)	EA	1									1A4MP14H4	
X2H		CLAMP, LOOP 312424 (02230)	EA	REF									1A4MP15	
X2H		NUT, PLAIN, HEXAGON MS35649-62 (96906)	EA	1									1A4MP15H1	
X2H		SCREW MACHINE MS35241-38 (96906)	EA	1									1A4MP15H2	
X2H		WASHER, FLAT MS27183-6 (96906)	EA	1									1A4MP15H3	
X2H		WASHER, LOCK MS35338-4 (96906)	EA	1									1A4MP15H4	
X2H		CLAMP LOOP 312424 (02230)	EA	REF									1A4MP16	
X2H		NUT, PLAIN, HEXAGON MS35649-62 (96906)	EA	1									1A4MP16H1	
X2H		SCREW MACHINE MS35241-38 (96906)	EA	1									1A4MP16H2	
X2H		WASHER, FLAT MS27183-6 (96906)	EA	1									1A4MP16H3	
X2H		WASHER, LOCK MS35338-41 (96906)	EA	1									1A4MP16H4	
PO	5355-933-7313	DIAL, CONTROL SMB380205-1 (80063)	EA	1				*	*	*	4	2	3-4 1A4MP17	
PO	5355-933-7314	DIAL, CONTROL SMB380205-2 (80063)	EA	1				*	*	*	4	2	3-4 1A4MP18	
PO	5355-933-7315	DIAL, CONTROL SMB380205-3 (80063)	EA	1				*	*	*	4	2	3-4 1A4MP19	
PO	5355-933-7316	DIAL, CONTROL SMB380205-4 (80063)	EA	1				*	*	*	4	2	3-4 1A4MP20	

SECTION II REPAIR PARTS FOR DIRECT SUPPORT, GENERAL SUPPORT, AND DEPOT MAINTENANCE (CONTINUED)

(1) SMR CODE	(2) FEDERAL STOCK NUMBER	(3) DESCRIPTION USABLE ON CODE REFER. NO. & MFR. CODE	(4) UNIT OF MEAS	(5) QTY INC IN UNIT	(6) 30-DAY DS MAINT ALLOWANCE			(7) 30-DAY GS MAINT ALLOWANCE			(8) 1 YR ALW PER EQUIP CNTGCT	(9) DEPOT MAINT ALW PER 100 EQUIP	(10) ILLUSTRATIONS	
					(a)	(b)	©	(a)	(b)	©			(a)	(b)
					1-20	21-50	51-100	1-20	21-50	51-100			FIG. NO.	ITEM NO. OR REFERENCE DESIGNATION
AHR		FLTR CCHK ASSY 002432 (02230)	EA	1									3-5	1A4A1
X2H		SCREW MACHINE MS35225-12 (96906)	EA	2										1A4A1MP1H2
X2H		WASHER, LOCK MS35338-40 (96906)	EA	2										1A4A1MP1H4
MD		TERMINAL BOARD 002502 (02230)	EA	1										1A4A1MP1
PH	6350-260-9224	BUZZER SMB380243 (80063)	EA	1				*	*	*	4	2		1A4A1DS1
X2H		NUT PLAIN, HEXAGON MS35649-42 (96906)	EA	2										1A4A1DS1MP1H2
X2H	5305-889-3116	SCREW MACHINE MS35206-213 (96906)	EA	2										1A4A1DS1MP1H4
X2H		WASHER, LOCK MS35338-40 (96906)	EA	2										1A4A1DS1MP1H6
PH		CAPACITOR, FIXED, ELECTROLYTIC CL24BH111UP3 (81349)	EA	1				REF	REF	REF	REF	REF		1A4A1C1
PH	5905-256-0411	RESISTOR, FIXED, COMPOSITION RC42GF181J (81349)	EA	1				*	*	2	8	3		1A4A1R1
PH	5961-577-6214	SEMICONDUCTOR IN538 (81349)	EA	2				REF	REF	REF	REF	REF	13	1A4A1CR1
PH	5961-577-6214	SEMICONDUCTOR IN538 (81349)	EA	REF				REF	REF	REF	REF	REF	13	1A4A1CR2
PC	5920-280-3167	FUSE CARTRIDGE 3131187 (75915)	EA	2				2	3	5	242	100	3-4	1A4F2
PH		FUSEHOLDER 292424 (02230)	EA	4				*	2	2	19	12	3-5	1A4XF2
PC	5920-280-3167	FUSE CARTRIDGE 313.187 (75915)	EA	REF				REF	REF	REF	REF	REF	3-4	1A4F3
PH		FUSEHOLDER 292424 (02230)	EA	REF				REF	REF	REF	REF	REF	3-5	1A4XF3
PC	5920-280-1367	FUSE CARTRIDGE SMD380242 (80063)	EA	2				2	3	5	242	100	3-4	1A4F4
PH		FUSEHOLDER 292424 (02230)	EA	REF				REF	REF	REF	REF	REF	3-5	1A4XF4
PC	5920-280-3167	FUSE CARTRIDGE SMD380242 (80063)	EA	REF				REF	REF	REF	REF	REF	3-4	1A4F5
PH		FUSEHOLDER 262424 (02230)	EA	REF				REF	REF	REF	REF	REF	3-5	1A4XF5
MD		GUARD SWITCH 002112 (02230)	EA	1										1A4MP21
X2H		FASTENER 122424 (02230)	EA	2										1A4MP21H2
X2H		SCREW MACHINE MS35225-17 (96906)	EA	2										1A4MP21H4
X2H		WASHER, FLAT MS27183-4 (96906)	EA	2										1A4MP21H6
X2H		WASHER, LOCK MS35338-40 (96906)	EA	2										1A4MP21H8

SECTION II REPAIR PARTS FOR DIRECT SUPPORT, GENERAL SUPPORT, AND DEPOT MAINTENANCE (CONTINUED)

(1) SMR CODE	(2) FEDERAL STOCK NUMBER	(3) DESCRIPTION USABLE ON CODE REFER. NO. & MFR. CODE	(4) UNIT OF MEAS	(5) QTY INC IN UNIT	(6) 30-DAY DS MAINT ALLOWANCE			(7) 30-DAY GS MAINT ALLOWANCE			(8) 1 YR ALW PER EQUIP CNTGCTY	(9) DEPOT MAINT ALW PER 100 EQUIP	(10) ILLUSTRATIONS	
					(a)	(b)	©	(a)	(b)	©			(a)	(b)
					1-20	21-50	51-100	1-20	21-50	51-100			FIG. NO.	ITEM NO. OR REFERENCE DESIGNATION
MD		HANDLE, BOW 002072 (02230)	EA	2										1A4MP22
X2H	5305-064-6751	SCREW MACHINE MS35226-64 (96906)	EA	2										1A4MP22H2
X2H	5310-045-3296	WASHER, LOCK MS35338-43 (96906)	EA	2										1A4MP22H4
MD		HANDLE, BOW 002072 (02230)	EA	REF										1A4MP23
X2H		SCREW MACHINE MS35226-64 (96906)	EA	2										1A4MP23H2
X2H		WASHER, LOCK MS35338-43 (96906)	EA	2										1A4MP23H4
PO	5355-160-5910	KNOB MS90120-2B01 (96906)	EA	5				*	2	2	19	15	3-4	1A4MP24
PO	5355-160-5910	KNOB MS90120-2B01 (96906)	EA	REF				REF	REF	REF	REF	REF	3-4	1A4MP25
PO	5355-160-5910	KNOB MS90120-2B01 (69906)	EA	REF				REF	REF	REF	REF	REF	3-4	1A4MP26
PO	5355-160-5910	KNOB MS90120-2B01 (96906)	EA	REF				REF	REF	REF	REF	REF	3-4	1A4MP27
PO	5355-160-5910	KNOB MS90120-2B01 (96906)	EA	REF				REF	REF	REF	REF	REF	3-4	1A4MP28
PO	5355-081-4572	KNOB MS90120-2G01 (96906)	EA	1				*	*	*	4	3	3-4	1A4MP29
PO	5355-753-5281	KNOB MS91528-1N2G (96906)	EA	5				*	2	2	19	15	3-4	1A4MP30
PO	5355-753-5281	KNOB MS91528-1N2G (96906)	EA	REF				REF	REF	REF	REF	REF	3-4	1A4MP31
PO	5355-753-5281	KNOB MS91528-1N2G (96906)	EA	REF				REF	REF	REF	REF	REF	3-4	1A4MP32
PO	5355-753-5281	KNOB MS91528-1N2G (96906)	EA	REF				REF	REF	REF	REF	REF	3-4	1A4MP33
PO	5355-753-5281	KNOB MS91528-1N2G (96906)	EA	REF				REF	REF	REF	REF	REF	3-4	1A4MP34
PC	6240-057-2887	LAMP MS15571-1 (81349)	EA	1				*	2	2	19	50	1	1A4DS1
PC	6240-223-9100	LAMP, NEON, NE-51 SMD380242 (02230)	EA	1				*	2	2	19	50	1	1A4DS2
PH	6625-971-6203	METER SMB-380249 (80063)	EA	1				*	2	2	16	2	1	1A4M1
X2H		PANEL 001804 (02230)	EA	1										1A4MP35
X2H		FASTENER 122424 (02230)	EA	4										1A4MP35H4
X2H		SCREW MACHINE MS35225-43 (96906)	EA	4										1A4MP35H8

SECTION II REPAIR PARTS FOR DIRECT SUPPORT, GENERAL SUPPORT, AND DEPOT MAINTENANCE (CONTINUED)

(1) SMR CODE	(2) FEDERAL STOCK NUMBER	(3) DESCRIPTION USABLE ON CODE REFER. NO. & MFR. CODE	(4) UNIT OF MEAS	(5) QTY INC IN UNIT	(6) 30-DAY DS MAINT ALLOWANCE			(7) 30-DAY GS MAINT ALLOWANCE			(8) 1 YR ALW PER EQUIP CNTGCTY	(9) DEPOT MAINT ALW PER 100 EQUIP	(10) ILLUSTRATIONS	
					(a)	(b)	©	(a)	(b)	©			(a)	(b)
					1-20	21-50	51-100	1-20	21-50	51-100			FIG. NO.	ITEM NO. OR REFERENCE DESIGNATION
X2H	5310-809-8544	WASHER, FLAT MS27183-7 (96906)	EA	4										1A4MP35H12
X2H		WASHER, LOCK MS35338-42 (96906)	EA	4										1A4MP35H16
MD		POINTER, DIAL 002062 (02230)	EA	4										1A4MP36
MD		SPACER, SLEEVE 002482 (02230)	EA	1										1A4MP36MP1
X2H		FASTENER 122424 (02230)	EA	1										1A4MP36MP1H2
X2H	5305-013-3384	SCREW MACHINE MS35241-25 (96906)	EA	2										1A4MP36MP1H4
X2H		POINTER, DIAL 002062 (02230)	EA	REF										1A4MP37
MD		SPACER, SLEEVE 002482 (02230)	EA	1										1A4MP37MP1
X2H		FASTENER 122424 (02230)	EA	1										1A4MP37MP1H2
X2H		SCREW MACHINE MS35241-25 (96906)	EA	2										1A4MP37MP1H4
X2H		POINTER, DIAL 002062 (02230)	EA	REF										1A4MP38
MD		SPACER.SLEEVE 002482 (02230)	EA	1										1A4MP38MP1
X2H		FASTENER 122424 (02230)	EA	1										1A4MP38MP1H2
X2H		SCREW MACHINE MS35241-25 (96906)	EA	2										1A4MP38MP1H4
X2H		POINTER, DIAL 002062 (02230)	EA	REF										1A4MP39
MD		SPACER, SLEEVE 002482 (02230)	EA	1										1A4MP39MP1
X2H		FASTENER 122424 (02230)	EA	2										1A4MP39MP1H2
X2H		SCREW MACHINE MS35241-25 (96906)	EA	2										1A4MP39MP1H4
PH		POST, BINDING 022424 (02230)	EA	13				*	2	2	59	13	3-4	1A4E1
PH		POST, BINDING 032424 (02230)	EA	REF				REF	REF	REF	REF	REF	3-4	1A4E2
PH		POST, BINDING 032424 (02230)	EA	REF				REF	REF	REF	REF	REF	3-4	1A4E3
PH		POST, BINDING 032424 (02230)	EA	REF				REF	REF	REF	REF	REF	3-4	1A4E4
PH		POST BINDING 032424 (02230)	EA	REF				REF	REF	REF	REF	REF	3-4	1A4E5
PH		POST, BINDING 032424 (02230)	EA	REF				REF	REF	REF	REF	REF	3-4	1A4E6
PH		POST, BINDING 032424 (02230)	EA	REF				REF	REF	REF	REF	REF		1A4E7

SECTION II REPAIR PARTS FOR DIRECT SUPPORT, GENERAL SUPPORT, AND DEPOT MAINTENANCE (CONTINUED)

(1) SMR CODE	(2) FEDERAL STOCK NUMBER	(3) DESCRIPTION USABLE ON CODE REFER. NO. & MFR. CODE	(4) UNIT OF MEAS	(5) QTY INC IN UNIT	(6) 30-DAY DS MAINT ALLOWANCE			(7) 30-DAY GS MAINT ALLOWANCE			(8) 1 YR ALW PER EQUIP CNTGCT	(9) DEPOT MAINT ALW PER 100 EQUIP	(10) ILLUSTRATIONS	
					(a)	(b)	©	(a)	(b)	©			(a)	(b)
					1-20	21-50	51-100	1-20	21-50	51-100			FIG. NO.	ITEM NO. OR REFERENCE DESIGNATION
PH		POST, BINDING 032424 (02230)	EA	REF				REF	REF	REF	REF	REF	3-4	1A4E8
PH		POST, BINDING 032424 (02230)	EA	REF				REF	REF	REF	REF	REF	3-4	1A4E9
PH		POST, BINDING 032424 (02230)	EA	REF				REF	REF	REF	REF	REF	3-4	1A4E10
PH		POST, BINDING 032424 (02230)	EA	REF				REF	REF	REF	REF	REF	3-4	1A4E11
PH		POST, BINDING 032424 (02230)	EA	REF				REF	REF	REF	REF	REF	3-4	1A4E12
PH		POST, BINDING 032424 (02230)	EA	REF				REF	REF	REF	REF	REF	3-4	1A4E13
PH		POST, BINDING 042424 (80063)	EA	2				*	2	2	13	2	3-4	1A4E14
PH		POST, BINDING 042424 (80063)	EA	REF				REF	REF	REF	REF	REF	3-4	1A4E15
PH		RESISTOR POWER RP102RD202KK (81349)	EA	1				*	*	2	8	3	3-5	1A4R1
MD		SUPPORT SMB381326 (80063)	EA	1										1A4MP40
MD		SUPPORT SMB380182 (80063)	EA	1										1A4MP41
PH	5930-449-2719	SWITCH, PUSHBUTTON 001883 (02230)	EA	1				*	*	2	8	5	3-5	1A4S5
MD		GASKET 003212 (02230)	EA	1										1A4S5MP1
X2H		NUT, PLAIN, HEXAGON MS35649-62 (96906)	EA	2										1A4S5MP1H2
X2H		SCREW MACHINE MS35225-31 (96906)	EA	2										1A4S5MP1H4
X2H		WASHER, FLAT MS27183-6 (96906)	EA	2										1A4S5MP1H6
X2H		WASHER LOCK MS35338-41 (96906)	EA	2										1A4S5MP1H8
PH	5930-448-2724	SWITCH, PUSHBUTTON, ASSEMBLY 002413 (02230)	EA	1				*	*	2	8	5	3-5	1A4S6
MD		GASKET 003282 (02230)	EA	2										1A4S6MP1
MD		GASKET 003282 (02230)	EA	REF										1A4S6MP2
X2H	5305-984-6194	SCREW MACHINE MS35206-246 (96906)	EA	2										1A4S6MP2H2
X2H		WASHER, FLAT MS27183-7 (96906)	EA	2										1A4S6MP2H4
X2H		WASHER, LOCK MS35338-42 (96906)	EA	2										1A4S6MP2H6
PH	5930-448-2725	SWITCH, PUSHBUTTON, ASSEMBLY 002992 (02230)	EA	1				*	*	2	8	5	3-5	1A4S7
MD		GASKET 003292 (02230)	EA	1										1A4S7MP1

SECTION II REPAIR PARTS FOR DIRECT SUPPORT, GENERAL SUPPORT, AND DEPOT MAINTENANCE (CONTINUED)

(1) SMR CODE	(2) FEDERAL STOCK NUMBER	(3) DESCRIPTION USABLE ON CODE REFER. NO. & MFR. CODE	(4) UNIT OF MEAS	(5) QTY INC IN UNIT	(6) 30-DAY DS MAINT ALLOWANCE			(7) 30-DAY GS MAINT ALLOWANCE			(8) 1 YR ALW PER EQUIP CNTGCTY	(9) DEPOT MAINT ALW PER 100 EQUIP	(10) ILLUSTRATIONS	
					(a)	(b)	©	(a)	(b)	©			(a)	(b)
					1-20	21-50	51-100	1-20	21-50	51-100			FIG. NO.	ITEM NO. OR REFERENCE DESIGNATION
X2H		NUT, PLAIN, HEXAGON MS35649-62 (96906)	EA	2										1A4S7MP1H2
X2H		SCREW MACHINE MS35225-31 (96906)	EA	2										1A4S7MP1H4
X2H		WASHER, FLAT MS27183-6 (96906)	EA	2										1A4S7MP1H6
X2H		WASHER, LOCK MS35338-41 (96906)	EA	2										1A4S7MP1H8
PH	5930-937-3912	SWITCH, ROTARY SMA380189 (80063)	EA	1				*	*	2	8	3	3-5	1A4S1
PH	5930-937-3913	SWITCH ROTARY SMA380190 (80063)	EA	1				*	*	2	8	3	3-5	1A4S2
PH	5930-937-1191	SWITCH, ROTARY SMA381305 (80063)	EA	1				*	*	2	8	3	3-5	1A4S3
PH	5930-982-9690	SWITCH, ROTARY SMA380191 (80063)	EA	1				*	*	2	8	3	3-5	1A4S4
PH	5930-982-9692	SWITCH, ROTARY SMA380192 (80063)	EA	1				*	*	2	8	3	3-5	1A4S9
PH	5930-615-9376	SWITCH, TOGGLE MS35059-21 (96906)	EA	1				*	*	2	8	3	3-5	1A4S8
X2H		TERMINAL LUG 1961 (73734)	EA	9										1A4E16
X2H		INSULATOR, STANDOFF 052424 (02230)	EA	1				REF	REF	REF	REF	REF		1A4E16E1
X2H		SCREW MACHINE MS35225-13 (96906)	EA	1										1A4E16MP1H1
X2H		TERMINAL LUG 1961 (73734)	EA	REF										1A4E17
X2H		INSULATOR, STANDOFF 052424 (02230)	EA	1										1A4E17E1
X2H		SCREW MACHINE MS35225-13 (96906)	EA	1										1A4E17MP1H1
X2H		TERMINAL LUG 1961 (73734)	EA	REF										1A4E18
X2H		INSULATOR, STANDOFF 052424 (02230)	EA	1										1A4E18E1
X2H		SCREW MACHINE MS35225-13 (96906)	EA	1										1A4E18MP1H1
X2H		TERMINAL LUG 1961 (73734)	EA	REF										1A4E19
X2H		INSULATOR, STANDOFF 052424 (02230)	EA	1										1A4E19E1
X2H		SCREW MACHINE MS35225-13 (96906)	EA	1										1A4E19MP1H1
X2H		TERMINAL LUG 1961 (73734)	EA	REF										1A4E20
X2H		INSULATOR, STANDOFF 052424 (02230)	EA	1										1A4E20E1
X2H		SCREW MACHINE MS35225-13 (96906)	EA	1										1A4E20MP1H1

SECTION II REPAIR PARTS FOR DIRECT SUPPORT, GENERAL SUPPORT, AND DEPOT MAINTENANCE (CONTINUED)

(1) SMR CODE	(2) FEDERAL STOCK NUMBER	(3) DESCRIPTION USABLE ON CODE REFER. NO. & MFR. CODE	(4) UNIT OF MEAS	(5) QTY INC IN UNIT	(6) 30-DAY DS MAINT ALLOWANCE			(7) 30-DAY GS MAINT ALLOWANCE			(8) 1 YR ALW PER EQUIP CNTGCTY	(9) DEPOT MAINT ALW PER 100 EQUIP	(10) ILLUSTRATIONS	
					(a)	(b)	©	(a)	(b)	©			(a)	(b)
					1-20	21-50	51-100	1-20	21-50	51-100			FIG. NO.	ITEM NO. OR REFERENCE DESIGNATION
X2H		TERMINAL LUG 1961 (73734)	EA	REF									1A4E21	
X2H		INSULATOR, STANDOFF 052424 (02230)	EA	1									1A4E21E1	
X2H		SCREW MACHINE MS35225-13 (96906)	EA	1									1A4E21MP1H1	
X2H		TERMINAL LUG 1961 (73734)	EA	REF									1A4E22	
X2H		INSULATOR, STANDOFF 052424 (02230)	EA	1									1A4E22E1	
X2H		SCREW MACHINE MS35225-13 (96906)	EA	1									1A4E22MP1H1	
X2H		TERMINAL LUG 1961 (73734)	EA	REF									1A4E23	
X2H		INSULATOR, STANDOFF 052424 (02230)	EA	1									1A4E23E1	
X2H		SCREW MACHINE MS35225-13 (96906)	EA	1									1A4E23MP1H1	
X2H		TERMINAL LUG 1961 (73734)	EA	REF									1A4E24	
X2H		INSULATOR, STANDOFF 052424 (02230)	EA	1									1A4E24E1	
X2H		SCREW MACHINE MS35225-13 (96906)	EA	1									1A4E24MP1H1	
X2H		TERMINAL LUG 121000 (73734)	EA	15									1A4E25	
X2H		TERMINAL LUG 121000 (73734)	EA	REF									1A4E26	
X2H		TERMINAL LUG 121000 (73734)	EA	REF									1A4E27	
X2H		TERMINAL LUG 121000 (73734)	EA	REF									1A4E28	
X2H		TERMINAL LUG 121000 (73734)	EA	REF									1A4E29	
X2H		TERMINAL LUG 121000 (73734)	EA	REF									1A4E30	
X2H		TERMINAL LUG 121000 (73734)	EA	REF									1A4E31	
X2H		TERMINAL LUG 121000 (73734)	EA	REF									1A4E32	
X2H		TERMINAL LUG 121000 (73734)	EA	REF									1A4E33	
X2H		TERMINAL LUG 121000 (73734)	EA	REF									1A4E34	
X2H		TERMINAL LUG 121000 (73734)	EA	REF									1A4E35	
X2H		TERMINAL LUG 121000 (73734)	EA	REF									1A4E36	
X2H		TERMINAL LUG 121000 (73734)	EA	REF									1A4E37	

SECTION II REPAIR PARTS FOR DIRECT SUPPORT, GENERAL SUPPORT, AND DEPOT MAINTENANCE (CONTINUED)

(1) SMR CODE	(2) FEDERAL STOCK NUMBER	(3) DESCRIPTION USABLE ON CODE REFER. NO. & MFR. CODE	(4) UNIT OF MEAS	(5) QTY INC IN UNIT	(6) 30-DAY DS MAINT ALLOWANCE			(7) 30-DAY GS MAINT ALLOWANCE			(8) 1 YR ALW PER EQUIP CNTGCT	(9) DEPOT MAINT ALW PER 100 EQUIP	(10) ILLUSTRATIONS	
					(a)	(b)	©	(a)	(b)	©			(a)	(b)
					1-20	21-50	51-100	1-20	21-50	51-100			FIG. NO.	ITEM NO. OR REFERENCE DESIGNATION
X2H		TERMINAL LUG 121000 (73734)	EA	REF									1A4E38	
X2H		TERMINAL LUG 121000 (73734)	EA	REF									1A4E39	
MD		SUPPORT 001813 (02230)	EA	1									1A4MP41	
PH	5950-470-1429	FIXED AUTO TRANSFORMER 002083 (02230)	EA	1				*	*	2	8	3	3-5 1A4T2	
X2H		SCREW MACHINE MS35225-17 (96906)	EA	4									1A4T2MP1H4	
X2H		WASHER, FLAT MS27183-4 (96906)	EA	4									1A4T2MP1H8	
X2H		WASHER, LOCK MS35338-40 (96906)	EA	4									1A4T2MP1H12	
PH	5905-552-3486	RESISTOR, VARIABLE RV4NAYSD103C (81349)	EA	1				*	*	2	8	3	3-5 1A4R12	
PH	5905-552-2265	RESISTOR, VARIABLE RV4NAYSD105A (81349)	EA	1				*	*	2	8	3	3-5 1A4R13	
PH	5905-556-6638	RESISTOR, VARIABLE RV4NAYSD502C (81349)	EA	1				*	*	2	8	3	3-5 1A4R14	
PH	5905-552-2859	RESISTOR, VARIABLE RV4NAYSD501A (81349)	EA	1				*	*	2	8	3	3-5 1A4R17	
PH	5905-581-1860	RESISTOR, VARIABLE RV4NAYSD500A (81349)	EA	1				*	*	2	8	3	3-5 1A4R18	

SECTION III.1. INDEX FEDERAL STOCK NUMBER CROSS REFERENCE

TO FIGURE AND ITEM NUMBER OR REFERENCE DESIGNATION

FEDERAL STOCK NUMBER	FIGURE NUMBER	ITEM NUMBER OR REF. DESIGNATION	FEDERAL STOCK NUMBER	FIGURE NUMBER	ITEM NUMBER OR REF. DESIGNATION
5305-013-3384	3-2	1A4MP36MP1H4	5310-013-4530		1A2A14C1MP1
5305-013-3436		1A4MP12H2	5310-013-4530		1A2A14MP1H2
5305-043-6637		1A3MP1H1	5310-013-4530		1A2A14MP2H2
5305-043-6638		1A2A14MP7H4	5310-013-4530		1A2A14MP3H2
5305-043-6639		1A3A11MP1H4	5310-013-4530		1A2A14MP12H1
5305-043-6664		1A3FL1MP1H4	5310-013-4530		1A2A14MP12H1
5305-043-6665		1A2MP1H4	5310-013-4530		1A2A14MP13H1
5305-043-6665		1A2A14MP1H4	5310-045-3296		1A4MP22H4
5305-043-6665		1A2A14MP2H4	5310-045-3299		1A2A14J2H6
5305-043-6665		1A2A14MP3H4	5310-045-4007		1A1A2MP1H15
5305-043-6666		1A2A2MP1H6	5310-045-4007		1A1A3MP1H15
5305-043-6666		1A2A2MP2H4	5310-045-4007		1A1A4MP1H15
5305-043-6746		1A4MP4H12	5310-045-4007		1A1A5MP1H15
5305-064-6751		1A4MP22H2	5310-045-4007		1A1A6MP1H15
5305-290-2066		1A4MP6H12	5310-045-4007		1A1A7MP1H15
5305-469-6886		1A4MP5	5310-045-4007		1A2MP1H8
5305-543-2188		1A1A2MP1H10	5310-045-4007		1A2A2MP1H12
5305-543-2188		1A1A3MP1H10	5310-045-4007		1A2A2MP2H8
5305-543-2188		1A1A4MP1H10	5310-045-4007		1A2AJ4C1MP1H4
5305-543-2188		1A1A5MP1H1	5310-045-4007		1A2A14MP1H8
5305-543-2188		1A1A6MP1H10	5310-045-4007		1A2A14MP2H8
5305-543-2188		1A1A7MP1H10	5310-045-4007		1A2A14MP3H8
5305-558-3671		1A2A14J5H3	5310-045-4007		1A2A14MP11H4
5305-638-1716		1A3A9MPH4	5310-045-4007		1A2A12MP12H4
5305-638-3286		1A3A9P1MP1H4	5310-045-4007		1A2A14MP13H4
5305-754-4343		1A3M6H2	5310-045-4007		1A2A2MP2H7
5305-754-4343		1A4AT11MP1H4	5310-080-6004		1A2A14C1MP1H3
5305-816-9242		1A3A6R1MP1MP5	5310-082-1404		1A2A14MP6H6
5305-889-2997		1A2A14J4H8	5310-082-1404		1A2A14MP6H6
5305-889-2997		1A2A14J11H6	5310-082-1404		1A2A14MP11H3
5305-889-3116		1A4A1DS1MP1H4	5310-082-1404		1A2A14MP12H3
5305-933-8220		1A2A4A3MP1	5310-082-1404		1A2A14MP13H3
5305-958-5453		1A2A4MP1H4	5310-087-0057		1A3A6R1MP1H4
5305-958-5473		1A2A41MP2H1	5310-515-8000		1A3A6R1MP1H2
5305-984-4982		1A2A14J2J1H1	5310-543-2410		1A2A14MP7H12
5305-984-4988		1A2A14C1MP1H2	5310-543-2628		1A2A2MP2H3
5305-984-6189		1A2A14J2H3	5310-687-6293		1A3A6R1MP1H2
5305-984-6194		1A4S6MP2H2	5310-753-5089		1A1A2MP3
5305-989-7434		1A2MP2H4	5310-753-5089		1A1A3MP2
5310-012-0614		1A4MP4H6	5310-753-5089		1A1A4MP2
5310-012-0622	1A3T1	5310-753-5089	1A1A5MP2		
5310-013-4530	1A1A2MP1H5	5310-753-5089	1A1A6MP2		
5310-013-4530	1A1A3MP1H5	5310-753-5089	1A1A7MP2		
5310-013-4530	1A1A4MP1H5	5310-761-6882	1A2A2MP2H1		
5310-013-4530	1A1A5MP1H5	5310-809-4058	1A2A2MP2H6		
5310-013-4530	1A1A6MP1H5	5310-809-8546	1A2MP2H8		
5310-013-4530	1A1A7MP1H5	5310-934-9739	1A2A14J4H4		
5310-013-4530	1A2MP1H2	5310-950-1310	1A3A11MP1H8		
5310-013-4530	1A2A2MP1H3	5310-951-4670	1A2A14MP7H8		
5310-013-4530	1A2A2MP2H2	5325-174-5317	1A3MP1		
		5325-174-5317	1A3MP5		

SECTION III.1. INDEX FEDERAL STOCK NUMBER CROSS REFERENCE

TO FIGURE AND ITEM NUMBER OR REFERENCE DESIGNATION

FEDERAL STOCK NUMBER	FIGURE NUMBER	ITEM NUMBER OR REF. DESIGNATION	FEDERAL STOCK NUMBER	FIGURE NUMBER	ITEM NUMBER OR REF. DESIGNATION
5325-185-0017		1A3MP3	5905-185-8510	3-10	1A3A4R4
5325-276-5954		1A3MP6	5905-185-8510	3-16	1A3A10R4
5325-276-6228		1A3MP2	5905-185-8521	3-11	1A3A5R5
5325-285-8363		1A3MP4	5905-186-3000	3-16	1A3A10R10
5325-291-9366		1A2A4A3MP2	5905-186-3000	3-16	1A3A10R11
5325-582-3601		1A3A11MP8	5905-190-8876	3-8	1A3A2R2
5330-584-1840		1A2A4A1MP1	5905-190-8879	3-8	1A3A2R19
5330-584-1840		1A2A4A2MP1	5905-190-8879	3-10	1A3A4R13
5340-469-8367		1A4MP1	5905-190-8879	3-10	1A3A4R14
5340-469-8367		1A4MP2	5905-190-8882	3-10	1A3A4R6
5340-469-8367		1A4MP3	5905-190-8882	3-10	1A3A4R7
5340-839-9050		1A2A14MP1H9	5905-190-8884	3-8	1A3A2R17
5340-839-9050		1A2A14MP2H9	5905-192-3787	3-16	1A3A10R3
5340-839-9050		1A2A14MP3H9	5905-192-3972	3-9	1A3A3R4
5355-081-4572	3-4	1A4MP29	5905-192-3981	3-8	1A3A2R1
5355-160-5910	3-4	1A4MP24	5905-192-3982	3-16	1A3A10R1
5355-160-5910	3-4	1A4MP25	5905-192-3987	3-8	1A3A2R18
5355-160-5910	3-4	1A4MP26	5905-192-3987	3-16	1A3A10R2
5355-160-5910	3-4	1A4MP27	5905-192-3988	3-9	1A3A3R13
5355-160-5910	3-4	1A4MP28	5905-192-3988	3-16	1A3A10R6
5355-753-5281	3-4	1A4MP30	5905-195-5514	3-7	1A3A1R4
5355-753-5281	3-4	1A4MP31	5905-195-5514	3-7	1A3A1R14
5355-752-5281	3-4	1A4MP32	5905-195-5514	3-9	1A3A3R15
5355-753-5281	3-4	1A4MP33	5905-195-5524	3-14	1A3A8R10
5355-753-5281	3-4	1A4MP34	5905-195-5571	3-8	1A3A2R22
5355-933-7313	3-4	1A4MP17	5905-195-6451	3-7	1A3A1R15
5355-933-7314	3-4	1A4MP18	5905-195-6451	3-8	1A3A2R9
5355-933-7315	3-4	1A4MP19	5905-195-6451	3-8	1A3A2R16
5355-933-7316	3-4	1A4MP20	5905-195-6451	3-8	1A3A2R20
5805-244-1915	3-2	1A3A11	5905-195-6451	3-9	1A3A3R14
5905-018-8887	3-10	1A3A4RT1	5905-195-6451	3-16	1A3A10R15
5905-018-8887	3-10	1A3A4RT2	5905-195-6741	3-10	1A3A4R3
5905-018-8887	3-10	1A3A4RT3	5905-195-6741	3-15	1A3A9R9
5905-050-1126	3-14	1A3A8R6	5905-195-6809	3-12	1A3A6R4
5905-067-3779	3-13	1A3A7R4	5905-195-6809	3-16	1A3A10R7
5905-067-3779	3-13	1A3A7R6	5905-195-6817	3-10	1A3A4R8
5905-069-2121	3-13	1A3A7R10	5905-195-6817	3-11	1A3A5R4
5905-069-3913	3-7	1A3A1R12	5905-195-6817	3-12	1A3A6R3
5905-171-1985	3-7	1A3A1R2	5905-195-6817	3-15	1A3A9R2
5905-171-1985	3-7	1A3A1R3	5905-195-6817	3-15	1A3A9R4
5905-171-2005	3-16	1A3A10R12	5905-198-4565	3-7	1A3A1R1
5905-171-2006	3-10	1A3A4R5	5905-198-4565	3-7	1A3A1R7
5905-185-6575	3-12	1A3A6R2	5905-198-4565	3-8	1A3A2R8
5905-185-8510	3-7	1A3A1R8	5905-198-4565	3-8	1A3A2R12
5905-185-8510	3-8	1A3A2R4	5905-198-4565	3-10	1A3A4R2
5905-185-8510	3-8	1A3A2R6	5905-245-0023	3-7	1A3A1R10
5905-185-8510	3-8	1A3A2R13	5905-245-0023	3-8	1A3A2R10
5905-185-8510	3-10	1A3A4R1	5905-245-0023	3-16	1A3A10R5

SECTION III.1. INDEX FEDERAL STOCK NUMBER CROSS REFERENCE

TO FIGURE AND ITEM NUMBER OR REFERENCE DESIGNATION

FEDERAL STOCK NUMBER	FIGURE NUMBER	ITEM NUMBER OR REF. DESIGNATION	FEDERAL STOCK NUMBER	FIGURE NUMBER	ITEM NUMBER OR REF. DESIGNATION
5905-252-4018	3-8	1A3A2R24	5905-728-4810	3-13	1A3A7R13
5905-256-0387	3-7	1A3A1R6	5905-752-3707	3-6	1A2A14R1
5905-256-0387	3-7	1A3A1R13	5905-752-7319	3-6	1A2A14R2
5905-256-0411		1A4A1R1	5905-763-3605	3-13	1A3A7R11
5905-257-2631	3-16	1A3A10R14	5905-763-5280	3-14	1A3A8R18
5905-257-4018	3-8	1A3A2R23	5905-799-8512	3-15	1A3A9R3
5905-258-6558	3-13	1A3A7R9	5905-814-4987	3-2	1A3R16
5905-279-1876	3-10	1A3A4R11	5905-816-7484	3-14	1A3A8R15
5905-279-1876	3-16	1A3A10R9	5905-833-3872	3-7	1A3A1R18
5905-279-2621	3-8	1A3A2R11	5905-844-2258	3-14	1A3A8R7
5905-279-2621	3-10	1A3A4R9	5905-855-5306	3-9	1A3A3R9
5905-279-2621	3-10	1A3A4R10	5905-882-0438	3-8	1A3A2R5
5905-279-2658	3-8	1A3A2R21	5905-883-4840	3-8	1A3A2R15
5905-279-2672	3-7	1A3A1R11	5905-892-7005	3-7	1A3A1R19
5905-279-2672	3-16	1A3A10R13	5905-914-5532	3-7	1A3A1R9
5905-279-3506	3-8	1A3A2R14	5905-942-9326	3-10	1A3A4R12
5905-299-2037	3-14	1A3A8R12	5905-951-8520	3-14	1A3A8R17
5905-401-6628	3-15	1A3A9R7	5905-952-1755	3-13	1A3A7R3
5905-471-6217	3-15	1A3A9R6	5905-969-5852	3-8	1A3A2R7
5905-471-6218	3-15	1A3A9R5	5905-978-7113	3-7	1A3A1R5
5905-471-6219	3-15	1A3A9R8	5905-978-7113	3-7	1A3A1R16
5905-539-3982	3-14	1A3A8R1	5905-978-7113	3-14	1A3A8R8
5905-542-7826	3-9	1A3A3R10	5905-982-3337	3-13	1A3A7R7
5905-552-2265	3-5	1A4R13	5905-983-5949	3-14	1A3A8R9
5905-552-2438	3-13	1A3A7R8	5905-984-1464	3-15	1A3A9R1
5905-552-2859	3-5	1A4R17	5905-584-7685	3-7	1A3A1R17
5905-552-3486	3-5	1A4R12	5905-988-2319	3-9	1A3A3R6
5905-552-6140	3-13	1A3A7R1	5905-993-2263	3-9	1A3A3R1
5905-552-7195	3-14	1A3A8R19	5905-993-2263	3-9	1A3AR11
5905-556-3779	3-9	1A3A3R2	5910-018-1944	3-7	1A3A1C2
5905-556-6638	3-5	1A4R14	5910-018-1944	3-7	1A3A1C6
5905-577-1869	3-9	1A3A3R3	5910-045-0603	3-16	1A3A10C5
5905-577-2704	3-16	1A3A10R8	5910-056-8633	3-15	1A3A9C3
5905-577-2829	3-9	1A3A3R7	5910-070-7654	3-8	1A3A2C8
5905-577-s735	3-14	1A3A8R16	5910-070-7654	3-8	1A3A2C11
5905-577-6736	3-14	1A3A8R14	5910-085-1230	3-16	1A3A10C1
5905-577-6765	3-9	1A3A3R5	5910-104-1339	3-10	1A3A4C7
5905-581-1054	3-8	1A3A2R3	5910-104-1339	3-10	1A3A4C8
5905-581-1860	3-5	1A4R18	5910-104-1341	3-10	1A3A4C4
5905-583-6005	3-11	1A3A5R3	5910-104-1341	3-10	1A3A4C6
5905-615-7730	3-9	1A3A3R8	5910-104-1341	3-13	1A3A7C2
5905-646-5678	3-14	1A3A8R11	5910-104-1341	3-16	1A3A10C4
5905-681-8755	3-13	1A3A7R12	5910-105-5476	3-9	1A3A3C1
5905-681-8757	3-14	1A3A8R4	5910-105-5476	3-9	1A3A3C8
5905-702-4397	3-10	1A3A4R15	5910-105-5476	3-10	1A3A4C1
5905-702-4397	3-10	1A3A4R16	5910-105-5476	3-10	1A3A4C2
5905-702-6278	3-2	1A3R9	5910-105-5478	3-11	1A3A5C3
5905-702-6278	3-2	1A3R11	5910-105-5748	3-12	1A3A6C3
5905-722-1770	3-13	1A3A7R2	5910-105-5478	3-12	1A3A6C4
			5910-113-0260	3-11	1A3A5C1
			5910-113-0260	3-11	1A3A5C2

SECTION III.1. INDEX FEDERAL STOCK NUMBER CROSS REFERENCE

TO FIGURE AND ITEM NUMBER OR REFERENCE DESIGNATION

FEDERAL STOCK NUMBER	FIGURE NUMBER	ITEM NUMBER OR REF. DESIGNATION	FEDERAL STOCK NUMBER	FIGURE NUMBER	ITEM NUMBER OR REF. DESIGNATION
5910-113-0260	3-12	1A3A6C1	5950-470-1432	3-7	1A3A1MP1
5910-113-0260	3-12	1A3A6C2	5950-470-1432		1A3A2MP1
5910-113-0280	3- 11	A3A5C4	5950-470-1432	3-9	1A3A3MP1
5910-781-8983	3-7	1A31C8	5950-470-1432		1A3A4MP1
5910-782-1973	3-8	A3A2C1	5950-470-1432	3-10	1A3A4T2
5910.823-1148	3-13	1A3A7C1	5950-470-1432	3-11	113A5MP1
5910-823-1538	3-7	1A3A1C5	5950-470-1432	3-13	1A3A7MP1
5910-826-8911	3-8	1A3A2C2	5950-470-1432		1A3A8MP1
5910-827-3571	3-11	1A3A5C5	5950-470-1432	3-15	1A3A9MP1
5910-835-2175	3-9	1A3A3C4	5950-470-1432	3-16	1A3A10MP1
5910-840-6570	3-9	1A3A3C5	5950-470-1433	3-13	1A3A7T1
5910-883-3286	3-12	1A3A6C5	5950-470-1434	3-2	1A3T1
5910-894-4546	3-9	1A3A3C7	5950-470-1435	3-2	1A3L1
5910-899-9129	3-8	1A3A2C5	5961-577-3022	3-7	1A3A101
5910-901-9467	3-6	1A2A14C1	5961-577-3022	3-7	1A3A1Q2
5910-913-3064	3-15	1A3A9C2	5961-577-3022	3-7	1A3A103
5910-926-0064	3-7	1A3A1C9	5961-577-3022	3-9	1A3A3Q1
5910-926-9784	3-15	1A3A9C4	5961-577-3022	3-9	1A3A3Q2
5910-926-9785	3-8	1A3AZC7	5961-577-3022	3-9	1A3A3Q3
5910-926-9786	3-9	1A3A3C2	5961-577-6214	3-11	113A5CR1
5910-926-9786	3-9	1A3A3C6	5961-577-6214	3-11	1A3A5CR2
5910-926-9786	3-9	1A3A3C9	5961-577-6214	13	1A4A1CR1
5910-926-9786	3-10	1A3A4C3	5961-577-6214	13	1A4A1CR2
5910-934-2920	3-8	1A3A2C9	5961-669-6884	3-8	1A3A2CR1
5910-934-2921	3-8	1A3A2C10	5961-669-6884	3-8	1A3A2CR2
5910-936-1334	3-16	1A3A10C3	5961-669-6884	3-8	1A3A2CR3
5910-936-4820	3-8	1A3A2C4	5961-669-6884	3-14	1A3A8CR1
5910-936-4820	3-8	1A3A2C6	5961-669-6884	3-14	1A3A8CR2
5910-959-4596	3-16	1A3A10C2	5961-669-6884	3-14	1A3A8CR3
5910-978-9338	3-15	1A3A9C1	5961-669-6884	3-14	1A3A8CR4
5915-931-6832	3-2	1A3FL1	5961-752-0338	3-8	1A3A2Q1
5915-931-6833	3-2	1A3FL4	5961-752-0338	3-8	1A3A2Q2
5915-931-6834	3-2	1A3FL3	5961-752-0338	3-8	1A3A2Q3
5915-931-6835	3-2	1A3FL2	5961-752-0338	3-8	1A3A2Q4
5920-229-1317	3-4	1A4F4	5961-752-0338	3-8	1A3A2Q5
5920-280-3167	3-4	1A4F2	5961-752-0338	3-10	1A3A4Q1
5920-280-3167	3-4	1A4F3	5961-752-0338	3-10	1A3A4Q2
5920-280-3167	3-4	1A4F5	5961-752-0338	3-10	1A3A4Q3
5930-448-2719	3-5	1A4S5	5961-752-5229	3-15	1A3A901
5930-448-2724	3-5	1A4S6	5961-752-5229	3-15	1A3A9Q2
5930-448-2723	3-5	1A4S7	5961-752-5229	3-16	1A3A10Q1
5930-615-9376	3-5	1A4S8	5961-752-5229	3-16	1A3A10Q2
5930-937-1191	3-5	1A4S3	5961-785-3219	3-8	1A3A2CR4
5930-937-3912	3-5	1A4S1	5961-809-9047	3-8	1A3A2Q6
5930-937-3913	3-5	1A4S2	5961-821-8976	3-2	1A3Q1
5930-982-9690	3-5	1A4S4	5961-842-9564	3-15	1A3A9CR2
5930-982-9692	3-5	1A4S9			
5950-476-1340	3-10	A3A4T1	5961-842-9864	3-15	1A3A9CR1
5950-470-1429	3-5	1A4T2	5961-842-9864	3-15	1A3A9CR3
5950-470-1431	3-10	1A3A4T3	5961-842-9864	3-16	1A3A10CR1

SECTION III.1. INDEX FEDERAL STOCK NUMBER CROSS REFERENCE

TO FIGURE AND ITEM NUMBER OR REFERENCE DESIGNATION

FEDERAL STOCK NUMBER	FIGURE NUMBER	ITEM NUMBER OR REF. DESIGNATION		FEDERAL STOCK NUMBER	FIGURE NUMBER	ITEM NUMBER OR REF. DESIGNATION
5961-842-9864	3-16	1A3A10CR2				
5961-842-9864	3-16	1A3A10CR3				
5961-842-9864	3-16	1A3A10CR4				
5961-843-5177	3-2	1A3CR2				
5961-951-6301	3-2	1A3CR1				
5965-448-2744	3-1	1A2A4A4				
5965-448-2745	3-1	1A2A2				
5985-984-1463	3-14	1A3A8R5				
6240-057-2887	1	1A4DS1				
6240-223-9100	1	1A4DS2				
6350-261-9224		1A4A1MP1				
6625-931-6804	3-2	1A3A10				
6625-931-6805	3-2	1A3A8				
6625-931-6806	3-2	1A3A9				
6625-931-6808	3-2	1A3A7				
6625-931-6809	3-2	1A3A1				
6625-931-6810	3-2	1A3A2				
6625-931-6814	3-2	1A3A4				
6625-931-6815	3-2	1A3A5				
6625-931-6816	3-2	1A3A6				
6625-938-6813	3-2	1A3A3				
6625-965-1433	1-1	1				
6625-971-6203	1	1A4M1				

SECTION III.2. INDEX FEDERAL STOCK NUMBER CROSS REFERENCE

TO FIGURE NUMBER REFERENCE DESIGNATION OR ITEM NUMBER

REFERENCE NO.	MFGRS CODE	FIG. NO.	REF. DESIGNATION OR ITEM NO.	REFERENCE NO.	MFGRS CODE	FIG. NO.	REF. DESIGNATION OR ITEM NO.
001764	02230	1-1	1A2	002602	02230		1A4MP6MP1
001774	02230	1-1	1A3	002602	02230		1A4MP6MP2
001792	02230		1A2A14MP1	002642	02230		1A2A14J13MP1
001792	02230		1A2A14MP2	002692	02230	3-1	1A2A4A2
001792	02230		1A2A14MP3	002712	02230	3-1	1A2A4A1
001804	02230		1A4MP35	002722	02230		1A2A4MP3
001813	02230		1A4MP41	002743	02230		1A2A4
001834	02230	1-1	1A3	002853	02230		1A2A3MP1
001872	02230		1A1A2MP1	002872	02230		1A2MP2MP1
001872	02230		1A1A3MP1	002882	02230		1A2MP2MP2
001872	02230		1A1A4MP1	002892	02230		1A2A4A1MP2
001872	02330		1A1A4MP3	002912	02230		1A2A4A3MP4
001872	02230		1A1A5MP1	002922	02230		1A2A4A3MP3
001872	02230		1A1A6MP1	002932	02230	3-1	1A2A4A3
001872	02230		1A1A6MP8	002942	02230		1A2A4A3MP6
001872	02230		1A1A7MP1	002952	02230		1A2A4A3MP5
001974-B	02230		1A2A1	002962	02230		1A3MP1
001982	02230		1A1A4	002962	02230		1A3MP2
001992	02230		1A1A2	002972	02230		1A4MP6
001992	02230		1A1A7	002982	02230		1A1A3MP1
002012	02230	3-1	12A14J2	003002	02230		1A2A2MP1
002042	02230		1A2A4A4MP2	003032	02230		1A2A2MP2
002062	02230		1A4MP36	003042	02230		1A1A2MP2
002062	02230		1A4MP37	003042	02230		1A1A4MP1
002062	02230		1A4MP38	003042	02230		1A1A5MP1
002062	02230		1A4MP39	003042	02230		1A1A6MP1
002072	02230		1A4MP22	003042	02230		1A17MP1
002072	02230		1A4MP23	003062	02230	3-10	1A3A4E1
002102	02230		1A2A4A3MP7	003072	02230	3-13	1A3A7E1
002112	02230		1A4M21	003082	02230		1A1A2MP4
002123	02230		1A2A3MP2	003082	02230		1A1A3MP3
002123	02230		1A2A3MP2H2	003082	02230		1A1A5MP3
002132	02230		1A2MP2	003082	02230		1A1A7MP3
002142	02230		1A2MP2MP3	003132	02230	3-8	1A3A2E1
002153	02230	13	1A4MP4	003142	02230		1A2MP1
002172	02230		1A2A4MP2	003182	02230		1A2A3MP2MP1
002197	02230	3-12	1A3AT1MP1	003193	02230	1-1	1A1
002272	02230	1-1	1A4	003202	02230	3-1	1A2A3
002432	02230	3-5	1A4A1	003212	02230		1A4S5MP1
002444	02230	3-1	1A2A14	003222	02230		1A3A11MP1
002462	02230		1A3A11MP9	003222	02230		1A3A11MP2
002462	02230		1A3A11MP10	003222	02230		1A3A11MP3
002462	02230		1A3A11MP11	003222	02230		1A3A11MP4
002462	02230		1A3A11MP12	003232	02230		1A1A3
002482	02230		1A4MP36MP1	003232	02230		1A1A5
002482	02230		1A4MP37MP1	003232	02230		1A1A6
002482	02230		1A4MP38MP1	003242	02230	3-7	1A3A1E1
002482	02230		1A4MP39MP1	003252	02230		1A2A14J2MP1
002502	02230		1A4A1MP1	003272	02230	3-11	1A3A5E1
002583	02230		1A2A14MP14	003282	02230		1A4S6MP1
002592	02230		1A2A4MP3MP1	003282	02230		1A4S6MP2

SECTION III.2. INDEX FEDERAL STOCK NUMBER CROSS REFERENCE

TO FIGURE NUMBER REFERENCE DESIGNATION OR ITEM NUMBER

REFERENCE NO.	MFGRS CODE	FIG. NO.	REF. DESIGNATION OR ITEM NO.	REFERENCE NO.	MFGRS CODE	FIG. NO.	REF. DESIGNATION OR ITEM NO.
003292	02230		1A4S7MP1	032424	02230	3-4	1A4E3
003302	02230	3-12	1A3A6E1	032424	02230	3-4	1A4E4
003312	02230	3-15	1A3A9E1	032424	02230	3-4	1A4E5
003322	02230	3-14	1A3A8E1	032424	02230	3-4	1A4E6
003342	02230		1A3A5R1MP1MP6	032424	02230	3-4	1A4E7
003342	02230		1A3A5R1MP1MP7	032424	02230	3-4	1A4E8
003342	02230		1A3A5R1MP1MP8	032424	02230	3-4	1A4E9
003342	02230		1A3A5R2MP1MP6	032424	02230	3-4	1A4E10
003342	02230		1A3A5R2MP1MP7	032424	02230	3-4	1A4E11
003342	02230		1A3A5R2MP1MP8	032424	02230	3-4	1A4E12
003342	02230		1A3A6R1MP1MP6	032424	02230	3-4	1A4E13
003342	02230		1A3A6R1MP1MP7	033202	02230		1A2A3MP1H2H2
003342	02230		1A3A6R1MP1MP8	042424	80063	3-4	1A4E14
003352	02230		1A3A5R3MP1MP6	042424	80063	3-4	1A4E15
003352	02230		1A3A5R3MP1MP7	043202	02230		1A2A3MP1X20H1
003352	02230		1A3A5R3MP1MP8	043202	02230		1A2A3MP2X10H1
003352	02230		1A3A5R5MP1MP6	052424	02230		1A4E16E1
003352	02230		1A3A5RSMP1MP7	052424	02230		1A4E17E1
003352	02230		1A3A5R5MPLMP8	052424	02230		1A4E18E1
003362	02230		1A3A11MP13	052424	02230		1A4E20E1
003362	02230		1A3A11MP14	052424	02230		1A4E21E1
003362	02230		1A3A11MP15	052424	02230		1A4E22E1
003362	02230		1A3A11MP16	052424	02230		1A4E23E1
003372	02230		1A3A11MP17	052424	02230		1A4E24E1
003372	02230		1A3A11MP18	052444	02230		1A2A14J5
003372	02230		1A3A11MP19	052444	02230	3-1	1A2A14J9
003372	02230		1A3A11MP20	062444	02230	3-1	1A2A14J11
003382	02230	3-11	1A3A5R1MP1	062444	02230	3-1	1A2A14J13
003382	02230		1A3A5R2MP1	071774	02230		1A3E2
003382	02230		1A3A6R1MP1	071774	02230		1A3E3
003392	02230		1A3A5R3MP1	071774	02230		1A3E4
003392	02230		1A3A5R5MP1	071774	02230		1A3E5
003442	02230		1A2A14MP4	072444	02230	3-1	1A2A14J8
003442	02230		1A2A14MP5	081774	02230	3-3	1A3J7
003442	02230		1A2A14MP6	081774	02230	3-3	1A3J8
003452	02230		1A2A14MP7	082424	02230	1-1	1A4W1
003492	02230	1-1	1A4W3	082424	02230	1-1	1A4W2
012012	02230		1A2A14J2J2	082444	02230	3-1	1A2A14J12
012122	02230		1A2A3MP2MP1MP2	091774	02230	3-3	1A3J1
012444	02230	3-1	1A2A14J1	091774	02230	3-3	1A3J2
013202	02230		1A2A3MP1X20	091774	02230	3-3	1A3J3
013202	02230		1A2A3MP2X10	091774	02230	3-3	1A3J4
013382	02230		1A3A5R1MP1MP1	091774	02230	3-3	1A3J5
013382	02230		1A3A5R2MP1MP1	091774	02230	3-3	1A3J6
013382	02230		1A3A6R1MP1MP1	091774	02230	3-3	1A3J9
013392	02230		1A3A5R3MP1MP1	091774	02230	3-3	1A3J10
013392	02230		1A3A5R5MP1MP1	092444	02230		1A2A14J4
022012	02230		1A2A14J2J1	101774	02230	3-3	1A3F1
022444	02230	3-1	1A2A14J3	101974-A	02230		1A1A1
				102424	02230		1A4MP7
				102424	02230		1A4MP8
023202	02230		1A2A3MP1H2				
023492	02230	1-1	1A4W3P1				
032424	02230	3-4	1A4E2				

SECTION III.2. INDEX FEDERAL STOCK NUMBER CROSS REFERENCE

TO FIGURE NUMBER REFERENCE DESIGNATION OR ITEM NUMBER

REFERENCE NO.	MFGRS CODE	FIG. NO.	REF. DESIGNATION OR ITEM NO.	REFERENCE NO.	MFGRS CODE	FIG. NO.	REF. DESIGNATION OR ITEM NO.
111774	02230		1A3XF1	212263	02230	3-7	1A3A1P1
112424	02230		1A4MP9	212263	02230	3-8	1A2A2P1
121000	73734		1A4E25	212263	02230	3-9	1A3A3P1
121000	73734		1A4E26	212263	02230	3-10	1A3A4P1
121000	73734		1A4E27	212263	02230	3-11	1A3A5P1
121000	73734		1A4E28	212263	02230	3-12	1A3A6P1
121000	73734		1A4E29	212263	02230	3-15	1A3A9P1
121000	73734		1A4E30	212263	02230	3-16	1A3A10P1
121000	73734		1A4E31	212444	02230	3-1	1A2A14J12H12
121000	73734		1A4E32	222343	02230	3-13	1A3A7P1
121000	73734		1A4E33	222343	02230	3-14	1A3A8P1
121000	73734		1A4E34	222424	02230	3-5	1A4AT1
121000	73734		1A4E35	232424	02230	3-5	1A4AT2
121000	73734		1A4E36	232424	02230	3-5	1A4AT3
121000	73734		1A4E37	242424	02230	3-5	1A4AT4
121000	73734		1A4E38	292424	02230	3-5	1A4XF3
121000	73734		1A4E39	292424	02230	3-5	1A4XF4
122424	02230		1A4P21H2	292424	02230	3-5	1A4XF5
122424	02230		1A4P35H4	302444	02230	3-1	1A2A14J7
122424	02230		1A4MP36MP1H2	312424	02230		1A4MP11
122424	02230		1A4MP37MP1H2	312424	02230		1A4MP13
122424	022u		1A4MP38MP1H2	312424	02230		1A4MP15
122424	02230		1A4MP39MPLH2	312424	02230		1A4MP16
14244	02230		1A2A14C1MP1	322424	02230		1A4MP10
14244	02230		1A2A14MP11	322424	02230		1A4MP12
14244	02230		1A2A14MP12	322424	02230		1A4MP14
152444	02230		1A2A14MP13	802652	02230	3-9	1A3A3E1
161774	02230		1A3J1MP1	803332	02230	3-16	1A3A10E1
161774	02230		1A3J5MP1	A003012	02230		1A2A4MP1
161774	02230		1A3J7MP1	ASK-224-46	02230		1A2A14MP6H3
161774	02230		1A3J9MP1	CL24BH111UP3	81349	3-9	1A3A3C3
161774	02230		1A3MP1	CL24BH111UP3	81349		1A4A1C1
161774	02230		1A3MP2	CS13AE106M	81349	3-7	1A3A1C1
162444	02230		1A2A14MP9	CS13AE106M	81349	3-7	1A3A1C4
171774	02230		1A3MP3	CS13AE106M	81349	-8	1A3A2C3
171774	02230		1A3MP4	CS13BD686M	81349	3-7	1A3A1C3
182444	02230	3-1	1A2A14J6	CS13BD686M	81349		1A3A1C7
192444	02230		1A2A14J12H4	CS13BD686M	81349	3-9	1A3A3C10
1961	73734		1A4E16	JAN 1N540	81349	3-11	1A3A5CR3
1961	73734		1A4E17	JAN 1N540	81349	3-11	1A3A5CR4
1961	73734		1A4E18	MS24647	96906		1A1A2MP3H2
1961	73734		1A4E19	MS24647	96906		1A1A3MP2H2
1961	73734		1A4E20	MS24647	96906		1A1A4MP2H2
1961	73734		1A4E21	MS24647	96906		1A1A5MP2H2
1961	73734		1A4E22	MS24647	96906		1A1A6MP2H2
1961	73734		1A4E23	MS24647	96906		1A1A7MP2H2
1961	73734		1A4E24	MS27183-2	96906		1A3A5R1MP1H4
201774	02230		1A3MP5	MS27183-2	96906		1A3A5R1MP1MP12
201774	02230		1A3MP6	MS27183-2	96906		1A3A5R2MP1H4
201774	02230		1A3MP7	MS27183-2	96906		1A3A5R2MP1MP12
201774	02230		1A3MP8	MS27183-2	96906		1A3A5R3MP1H4
202444	02230		1A2A14J12H8	MS27183-2	96906		1A3A5R3MP1MP12

SECTION III.2. INDEX FEDERAL STOCK NUMBER CROSS REFERENCE

TO FIGURE NUMBER REFERENCE DESIGNATION OR ITEM NUMBER

REFERENCE NO.	MFGRS CODE	FIG. NO.	REF. DESIGNATION OR ITEM NO.	REFERENCE NO.	MFGRS CODE	FIG. NO.	REF. DESIGNATION OR ITEM NO.
MS27183-2	96906		1A3A5R5MPH4	MS27183-6	96906		1A3MP8H3
MS27183-2	96906		1A3A5R5MP1MP12	MS27183-6	96906		1A4MP10H3
MS27183-3	96906		1A2A14J13H6	MS27183-6	96906		1A4MP11H3
MS27183-3	96906		1A3A1MP1H6	MS27183-6	96906		1A4MP12H3
MS27183-3	96906		1A3A1P1MP1H6	MS27183-6	96096		1A4MP13H3
MS27183-3	96906		1A3A2MP1H6	MS27183-6	96096		1A4MP14H3
MS27183-3	96906		1A3A2P1MP1H6	MS27183-6	96096		1A4MP15H3
MS27183-3	96906		1A3A3MP1H6	MS27183-6	96096		1A4MP16H3
MS27183-3	96906		1A3A3P1MP1H6	MS27183-6	96906		1A4S5MP1H6
MS27183-3	96906		1A3A4MP1H6	MS27183-6	96906		1A4S7MP1H6
MS27183-3	96906		1A3A4P1MP1H6	MS27183-7	96906		1A4MP35H12
MS27183-3	96906		1A3A5MP1H6	MS27183-7	96906		1A3S6MP2H4
MS27183-3	96906		1A3A5P1MP1H6	MS35223-17	96906		1A3A1MP1H4
MS27183-3	96906		1A3A6MP1H6	MS35223-17	96906		1A3A2MP1H4
MS27183-3	96906		1A3A6P1MP1H6	MS35223-17	96906		1A3A3MP1H4
MS27183-3	96906		1A3A7MP1H6	MS35223-17	96906		1A3A4MP1H4
MS27183-3	96906		1A3A7P1MP1H6	MS35223-17	96906		1A3A5MP1H4
MS27183-3	96906		1A3A8MPH6	MS35223-17	96906		1A3A6MP1H4
MS27183-3	96906		1A3A8P1MP1H6	MS35223-17	96906		1A3A7MP1H4
MS27183-3	96906		1A3A9MP1H6	MS35223-17	96906		1A3A8MP1H4
MS27183-3	96906		1A349P1MP1H6	MS35223-17	96906		1A3A10MP1H4
MS27183-3	96906		1A3A10MP1H6	MS35223-18	96906		1A3A1P1MP1H4
MS27183-3	96906		1A3A10P1MP1H6	MS35223-18	96906		1A3A2P1MP1H4
MS27183-4	96906		1A3MP1H2	MS35223-18	96906		1A3A3P1MP1H4
MS27183-4	96906		1A3MP2H2	MS35223-18	96906		1A3A4P1MP1H4
MS27183-4	96906		1A4MP21H6	M535223-18	96906		1A3A5P1MP1H4
MS27183-4	96906		1A4T2MP1H8	MS35223-18	96906		1A3A6P1MP1H4
MS27183-5	96906		1A2MP1H6	MS35223-18	96906		1A3A7P1MP1H4
MS27183-5	96906		1A2A2MP1H9	MS35223-18	96906		1A3A8P1MP1H4
MS27183-5	96906		1A2A2MP2H6	MS35223-18	96906		1A3A10P1MP1H4
MS27183-5	96906		1A2A3MP1H6	MS35225-7	96906		1A2A14J9H3
MS27183-5	96906		1A2A14MP1H6	MS35225-7	96906		1A2A14J13M1H3
MS27183-5	96906		1A2A14MP2H6	MS35225-12	96906		1A3MP1H1
MS27183-5	96906		1A2A14MP3H6	MS35225-12	96906		1A4A1MP1H2
MS27183-6	96906		1A3J1MP1H6	M535225-13	96906		1A2A14J13H4
MS27183-6	96906		1A3J2MP1H6	MS35225-13	96906		1A3E1MP1H1
MS27183-6	96906		1A3J3MP1H6	MS35225-13	96906		1A3E2MP1H1
MS27183-6	96906		1A3J4MP1H6	MS35225-13	96906		1A3E3MP1H1
MS27183-6	96906		1A3J5MP1H6	MS35225-13	96906		1A3E4MP1H1
MS27183-6	96906		1A3J6MP1H6	MS35225-13	96906		1A3E5MP1H1
MS27183-6	96906		1A3J7MP1H6	MS35225-13	96906		1A4E16MP1H1
MS27183-6	96906		1A3J8MP1H6	MS35225-13	96906		1A4E17MP1H1
MS27183-6	96906		1A3J9MP1H4	MS35225-13	96906		1A4E18MP1H1
MS27183-6	96906		1A3J10MP1H6	MS35225-13	96906		1A4E19MP1H1
MS27183-6	96906		1A3MP1H3	MS35225-13	96906		1A4E20MP1H1
MS27183-6	96906		1A3MP2H3	MS35225-13	96906		1A4E21MP1H1
MS27183-6	96906		1A3MP3H3	MS35225-13	96906		1A4E22MP1H1
MS27183-6	96906		1A3MP4H3	MS35225-13	96906		1A4E23MP1H1
MS27183-6	96906		1A3MP5H3	MS35225-13	96906		1A4E24MP1H1
MS27183-6	96906		1A3MP6H3	MS35225-17	96906		1A4MP21H4
MS27183-6	96906		1A3MP7H3	MS35225-17	90906		1A4T2MP1H4

SECTION III.2. INDEX FEDERAL STOCK NUMBER CROSS REFERENCE

TO FIGURE NUMBER REFERENCE DESIGNATION OR ITEM NUMBER

REFERENCE NO.	MFGRS CODE	FIG. NO.	REF. DESIGNATION OR ITEM NO.	REFERENCE NO.	MFGRS CODE	FIG. NO.	REF. DESIGNATION OR ITEM NO.
MS35225-25	96906		1A2A14J2J2H1	MS35335-15	96906		1A3A1MP1H8
MS35225-28	96906		1A2A3MP2MP1H4	MS35335-15	96906		1A3A1P1MP1H8
MS35225-28	96906		1A2A14MP11H2	MS35335-15	96906		1A3A2MP1H8
MS35225-28	96906		1A2A14MP12H2	MS35335-15	96906		1A3A2P1MP1H8
MS35225-28	96906		1A2A14MP13H2	MS35335-15	96906		1A3A3MP1H8
MS35225-29	96906		1A3FL2MP1H4	MS35335-15	96906		1A3A3P1H8
MS35225-29	96906		1A3FL3MP1H4	MS35335-15	96906		1A3A4MP1H8
MS35225-29	96906		1A3FL4MP1H4	MS35335-15	96906		1A3A4P1MP1H8
MS35225-29	96906		1A3XF1MP1H4	MS35335-15	96906		1A3A5MP1H8
MS35225-29	96906		1A4MP1H4	MS35335-15	96906		1A3A5P1MP1H8
MS35225-29	96906		1A4MP2H4	MS35335-15	96906		1A3A6MP1H8
MS35225-29	96906		1A4MP3H4	MS35335-15	96906		1A3A6P1MP1H8
MS35225-30	96906		1A4MP6H16	MS35335-15	96906		1A3A7MP1H8
MS35225-31	96906		1A2A3MP1H4	MS35335-15	96906		1A3A7P1MP1H8
MS35225-31	96906		1A3J1MP1H4	MS35335-15	96906		1A3A8MP1H8
MS35225-31	96906		1A3J2MP1H4	MS35335-15	96906		1A3A8P1MP1H8
MS35225-31	96906		1A3J3MP1H4	MS35335-15	96906		1A3A9MP1H8
MS35225-31	96906		1A3J4MP1H4	MS35335-15	96906		1A3A9P1MP1H8
MS35225-31	96906		1A3J5MP1H4	MS35335-15	96906		1A3A10MP1H8
MS35225-31	96906		1A3J6MP1H4	MS35335-15	96906		1A3A10P1MP1H8
MS35225-31	96906		1A3J7MP1H4	MS35337-39	96906		1A3A5R1MP1H6
MS35225-31	96906		1A3J8MP1H4	MS35337-39	96906		1A3A5R2MP1H6
MS35225-31	96906		1A3J9MP1H4	MS35337-39	96906		1A3A5R3MP1H6
MS35225-31	96906		1A3J10MP1H4	MS35337-39	96906		1A3A5R5MP1H6
MS35225-31	96906		1A3MP1H2	MS35338-40	96906		1A2A14J4H12
MS35225-31	96906		1A3MP2H2	MS35338-40	96906		1A2A14J11H9
MS35225-31	96906		1A3MP3H2	MS35338-40	96906		1A3MP1H3
MS35225-31	96906		1A3MP4H2	MS35338-40	96906		1A3MP2H3
MS35225-31	96906		1A3MP5H2	MS35338-40	96906		1A3A11MP1H12
MS35225-31	96906		1A4S5MP1H4	MS35338-40	96906		1A4MP21H8
MS35225-31	96906		1A4S7MP1H4	MS35338-40	96906		1A4A1DS1MP1H6
MS35225-43	96906		1A4MP35H8	MS35338-40	96906		1A4A1MP1H4
MS35226-64	96906		1A4MP23H2	MS35338-40	96906		1A4T2MP1H12
MS35239-15	96906		1A3A5R1MP1MP5	MS35338-41	96906		1A2A3MP1H8
MS35239-15	96906		1A3A5R2MP1MP5	MS35338-41	96906		1A2A3MP2MP1H6
MS35239-15	96906		1A3A5R3MP1MP5	MS35338-41	96906		1A3FL1MP1H8
MS35239-15	96906		1A3A5R5MP1MP5	MS35338-41	96906		1A3FL2MP1H8
MS35239-34	96906		1A3MP7H2	MS35338-41	96906		1A3FL3MP1H8
MS35239-34	96906		1A3MP8H2	MS35338-41	96906		1A3FL4MP1H8
MS35239-34	96906		1A4AT2MP1H4	MS35338-41	96906		1A3J1MP1H8
MS35239-34	96906		1A4AT3MP1H4	MS35338-41	96906		1A3J2MP1H8
MS35239-34	96906		1A4AT4MP1H4	MS35338-41	96906		1A3J3MP1H8
MS35239-34	96906		1A4MP10H2	MS35338-41	96906		1A3J4MP1H8
MS35239-34	96906		1A4MP11H2	MS35338-41	96906		1A3J5MP1H8
MS35241-25	96906		1A4MP37MP1H4	MS35338-41	96906		1A3J6MP1H8
MS35241-25	96906		1A4MP38MP1H4	MS35338-41	96906		1A3J7MP1H8
MS35241-25	96906		1A4MP39MP1H4	MS35338-41	96906		1A3J8MP1H8
MS35241-38	96906		1A4MP13H2	MS35338-41	96906		1A3J9MP1H8
MS35241-38	96906		1A4MP14H2	MS35338-41	96906		1A3J10MP1H8
MS35241-38	96906		1A4MP15H2	MS35338-41	96906		1A3L1MP1H2
MS35241-38	96906		1A4MP16H2	MS35338-41	96906		1A3MP1H4
MS35241-50	96906		1A2A4MP3MP1H1	MS35338-41	96906		1A3MP2H4

SECTION III.2. INDEX FEDERAL STOCK NUMBER CROSS REFERENCE

TO FIGURE NUMBER REFERENCE DESIGNATION OR ITEM NUMBER

REFERENCE NO.	MFGRS CODE	FIG. NO.	REF. DESIGNATION OR ITEM NO.	REFERENCE NO.	MFGRS CODE	FIG. NO.	REF. DESIGNATION OR ITEM NO.
MS35338-41	96906		1A3MP3H4	MS35649-42	96906		1A3A9P1MP1H2
MS35338-41	96906		1A3MP4H4	MS35649-42	96906		1A3A10MP1H2
MS35338-41	96906		1A3MP5H4	MS35649-42	96906		1A3A10P1MP1H2
MS35338-41	96906		1A3MP6H4	MS35649-42	96906		1A4A1DS1MP1H2
MS35338-41	96906		1A3MP7H4	MS35649-62	96906		1A2A3MP1H2
MS35338-41	96906		1A3MP8H4	MS35649-62	96906		1A2A3MP3MP1H2
MS35338-41	96906		1A3XF1MP1H6	MS35649-62	96906		1A2A14J13H2
MS35338-41	96906		1A4MP1H6	MS35649-62	96906		1A3J2MP1H2
MS35338-41	96906		1A4MP2H6	MS35649-62	96906		1A3J3MP1H2
MS35338-41	96906		1A4MP3H6	MS35649-62	96906		1A3J4MP1H2
MS35338-41	96906		1A4MP4H18	MS35649-62	96906		1A3J5MP1H2
MS35338-41	96906		1A4MP10H4	MS35649-62	96906		1A3J6MP1H2
MS35338-41	96906		1A4MP11H4	MS35649-62	96906		1A3J7MP1H2
MS35338-41	96906		1A4MP12H4	MS35649-62	96906		1A3J8MP1H2
MS35338-41	96966		1A4MP13H4	MS35649-62	96906		1A3J9MP1H2
MS35338-41	96906		1A4MP14H4	MS35649-62	96906		1A3J10MP1H2
MS35338-41	96906		1A4MP15H4	MS35649-62	96906		1A3L1MP1H2
MS35338-41	96906		1A4MP16H4	MS35649-62	96906		1A3MP1H1
MS35338-41	96906		1A4S5MP1H8	MS35649-62	96906		1A3MP2H1
MS35338-41	96906		1A4S7MP1H8	MS35649-62	96906		1A3MP3H1
MS35338-42	96906		1A2A14J3H2	MS35649-62	96906		1A3MP4H1
MS35338-42	96906		1A3T1MP1H8	MS35649-62	96906		1A3MP5H1
MS35338-42	96906		1A4MP6H20	MS35649-62	96906		1A3MP6H1
MS35338-42	96906		1A4MP35H16	MS35649-62	96906		1A3MP7H1
MS35338-42	96906		1A4S6MP2H6	MS35649-62	96906		1A3MP8H1
MS35338-43	96906		1A4MP23H4	MS35649-62	96906		1A3XF1MP1H2
MS35649-22	96906		1A3A5R1MP1H2	MS35649-62	96906		1A4MP10H1
MS35649-22	96906		1A3A5R1MP1MP3	MS35649-62	96906		1A4MP11H1
MS35649-22	96906		1A3A5R2MP1H2	MS35649-62	96906		1A4MP12H1
MS35649-22	96906		1A3A5R2MP1MP3	MS35649-62	96906		1A4MP13H1
MS35649-22	96906		1A3A5R3MP1H2	MS35649-62	96906		1A4MP14H1
MS35649-22	96906		1A3A5R3MP1MP3	MS35649-62	96906		1A4MP15H1
MS35649-22	96906		1A3A5R5MP1H2	MS35649-62	96906		1A4MP16H1
MS35649-22	96906		1A3A5R5MP1MP3	MS35649-62	96906		1A4S5MP1H2
MS35649-22	96906		1A3A6R1MP1MP3	MS35649-62	96906		1A4S7MP1H2
MS35649-42	96906		1A2A14J11H3	MS35649-82	96906		1A4MP6H8
MS35649-42	96906		1A3A1MP1H2	PVC-105/15	92194		1A3A5R1E1
MS35649-42	96906		1A3A1P1MP1H2	PVC-105/15	92194		1A3A5R1E2
MS35649-42	96906		1A3A2MP1H2	PVC-105/15	92194		1A3A5R2E1
MS35649-42	96906		1A3A2P1MP1H2	PVC-105/15	92194		1A3ASR2E2
MS35649-42	96906		1A3A3MP1H2	PVC-105/15	92194		1A3A5R3E1
MS35649-42	96906		1A3A3P1MP1H2	PVC-105/15	92194		1A3A5R3E2
MS35649-42	96906		1A3A4P1MP1H2	PVC-105/15	92194		1A3A5R5E1
MS35649-42	96906		1A3A5MP1H2	PVC-105/15	92194		1A3A5R5E2
MS35649-42	96906		1A3A5P1MP1H2	PVC-105/15	92194		1A3A6R1E1
MS35649-42	96906		1A3A6MP1H2	PVC-105/15	92194		1A3A6R1E2
MS35649-42	96906		1A3A6P1MP1H2	RA20LASB203A	81349	3-2	1A3R15
MS35649-42	96906		1A3A7MP1H2	RB36L4	73168	3-8	1A3A2RT1
MS35649-42	96906		1A3A7P1MP1H2	RC20GF153K	81349	3-9	1A3A3R12
MS35649-42	96906		1A3A8MP1H2	RN60B1151F	81349	3-7	1A3A1R20
MS35649-42	96906		1A3A8P1MP1H2	RN60B3401F	81349	3-13	1A3A7R5
MS35649-42	96906		1A3A9MP1H2	RN60B6190F	81349	3-13	1A3A7R14
				RN70C3000F	81349	3-13	1A3A7R15

SECTION III.2. INDEX FEDERAL STOCK NUMBER CROSS REFERENCE

TO FIGURE NUMBER REFERENCE DESIGNATION OR ITEM NUMBER

REFERENCE NO.	MFGRS CODE	FIG. NO.	REF. DESIGNATION OR ITEM NO.	REFERENCE NO.	MFGRS CODE	FIG. NO.	REF. DESIGNATION OR ITEM NO.
RP102RD202KK	81349	3-5	1A4R1				
RW57V122	81349	3-14	1A3A8R2				
RW57V282	81349	3-14	1A3A8R3				
RW57V400	81349	3-11	1A3A5R2				
RW57V900	81349	3-12	1A3A6R1				
RW57V500	81349	3-11	1A3A5R1				
S-632-2	46384		1A4MP2H2				
S-632-2	46384		1A4MP3H2				
SMB380182	80063	3-5	1A4MP41				
SMB381320	02230		1A2A3MP2MP1H2				
SMB381326	80063		1A4MP40				
SMC380212	80063		1A2A3MP2P1				
SMD380177	02230		1A3E1				
SMD380242	02230	3-4	1A4E1				

**SECTION IV. INDEX-REFERENCE DESIGNATION
CROSS REFERENCE TO PAGE NUMBER**

REFERENCE DESIGNATION	PAGE NO.	REFERENCE DESIGNATION	PAGE NO.	REFERENCE DESIGNATION	PAGE NO.
1	B-4	1A1A7MP2H2	B-6	1A2A4MP1	B-11
1A1	B-4	1A1A7MP3	B-6	1A2A4MP1H4	B-11
1A1A1	B-4	1A2	B-6	1A2A4MP2	B-12
1A1A2	B-4	1A2MP1	B-6	1A2A4MP3	B-12
1A1A2MP1	B-4	1A2MP1H2	B-6	1A2A4MP3MP1	B-12
1A1A2MP1H5	B-4	1A2MP1H4	B-6	1A2A4MP3MP1H1	B-12
1A1A2MP1H10	B-4	1A2MP1H6	B-6	1A2A4A1	B-12
1A1A2MP1H15	B-4	1A2MP1H8	B-6	1A2A4A1MP1	B-12
1A1A2MP2	B-4	1A2MP2	B-10	1A2A4A1MP2	B-12
1A1A2MP3	B-4	1A2MP2H4	B-10	1A2A4A1MP2H1	B-12
1A1A2MP3H2	B-4	1A2MP2H8	B-10	1A2A4A2	B-12
1A1A2MP4	B-4	1A2MP2MP1	B-10	1A2A4A2MP1	B-12
1A1A3	B-4	1A2MP2MP2	B-10	1A2A4A3	B-12
1A1A3MP1	B-4	1A2MP2MP3	B-10	1A2A4A3MP1	B-12
1A1A3MP1H5	B-4	1A2A1	B-6	1A2A4A3MP2	B-12
1A1A3MP1H10	B-4	1A2A2	B-6	1A2A4A3MP3	B-12
1A1A3MP1H15	B-4	1A2A2MP1	B-6	1A2A4A3MP4	B-12
1A1A3MP2	B-4	1A2A2MP1H3	B-6	1A2A4A3MP5	B-12
1A1A3MP2H2	B-4	1A2A2MP1H6	B-6	1A2A4A3MP6	B-12
1A1A3MP3	B-4	1A2A2MP1H9	B-6	1A2AA43MP7	B-12
1A1A4	B-4	1A2A2MP1H12	B-6	1A2A4A4	B-12
1A1A4MP1	B-4	1A2A2MP2	B-6	1A2A4A4MP2	B-12
1A1A4MP1H5	B-4	1A2A2MP2H1	B-7	1A2A14	B-7
1A1A4MP1H10	B-4	1A2A2MP2H2	B-6	1A2A14C1	B-8
1A1A4MP1H15	B-5	1A2A2MP2H3	B-7	1A2A14C1MP1	B-8
1A1A4MP2	B-5	1A2A2MP2H4	B-6	1A2A14C1MP1H2	B-8
1A1A4MP2H2	B-5	1A2A2MP2H6	B-6	1A2A14C1MP1H3	B-8
1A1A4MP3	B-5	1A2A2MP2H7	B-7	1A2A14C1MP1H4	B-8
1A1A5	B-5	1A2A2MP2H8	B-6	1A2A14J1	B-10
1A1A5MP1	B-5	1A2A3	B-11	1A2A14J2	B-10
1A1A5MP1H5	B-5	1A2A3MP1	B-11	1A2A14J2H3	B-10
1A1A5MP1H10	B-5	1A2A3MP1H2	B-11	1A2A14J2H6	B-10
1A1A5MP1H15	B-5	1A2A3MP1H2H2	B-11	1A2A14J2J1	B-10
1A1A5MP2	B-5	1A2A3MP1H4	B-11	1A2A14J2J1H1	B-10
1A1A5MP2H2	B-5	1A2A3MP1H6	B-11	1A2A14J2J2	B-10
1A1A5MP3	B-5	1A2A3MP1H8	B-11	1A2A14J2J2H1	B-10
1A1A6	B-5	1A2A3MP1X20	B-11	1A2A14J2MP1	B-10
1A1A6MP1	B-5	1A2A3MP1X20H1	B-11	1A2A14J3	B-10
1A1A6MP1H5	B-5	1A2A3MP2	B-11	1A2A14J3H2	B-10
1A1A6MP1H10	B-5	1A2A3MP2H2	B-11	1A2A14J4	B-9
1A1A6MP1H15	B-5	1A2A3MP2MP1	B-11	1A2A14J4H4	B-9
1A1A6MP2	B-5	1A2A3MP2MP1H2	B-11	1A2A14J4H8	B-9
1A1A6MP2H2	B-5	1A2A3MP2MP1H4	B-11	1A2A14J4H12	B-9
1A1A6MP8	B-5	1A2A3MP2MP1H6	B-11	1A2A14J5	B-9
1A1A7	B-5	1A2A3MP2MP1MP2	B-11	1A2A14J5H3	B-9
1A1A7MP1	B-5	1A2A3MP2P1	B-11	1A2A14J6	B-9
1A1A7MP1H5	B-6	1A2A3MP2X10	B-11	1A2A14J7	B-9
1A1A7MP1H10	B-6	1A2A3MP2X10H1	B-11	1A2A14J8	B-10
1A1A7MP1H15	B-6	1A2A3MP3MP1H2	B-11	1A2A14J9	B-9
1A1A7MP2	B-6	1A2A4	B-11	1A2A14J9H3	B-9

**SECTION IV. INDEX-REFERENCE DESIGNATION
CROSS REFERENCE TO PAGE NUMBER**

REFERENCE DESIGNATION	PAGE NO.	REFERENCE DESIGNATION	PAGE NO.	REFERENCE DESIGNATION	PAGE NO.
1A2A14J11	B-9	1A2A14MP12H4	B-8	1A3J3MP1H8	B-32
1A2A14J11H3	B-9	1A2A14MP13	B-8	1A3J4	B-32
1A2A14J11H6	B-9	1A2A14MP13H1	B-9	1A3J4MP1H2	B-32
1A2A14J12	B-9	1A2A14MP13H2	B-9	1A3J4MP1H4	B-32
1A2A14J12H4	B-9	1A2A14MP13H3	B-9	1A3J4MP1H8	B-32
1A2A14J12H8	B-9	1A2A14MP14	B-10	1A3J5	B-32
1A2A14J12H12	B-9	1A2A14R1	B-10	1A3J5MP1	B-32
1A2A14J13	B-9	1A2A14R2	B-10	1A3J5MP1H2	B-32
1A2A14J13H2	B-10			1A3J5MP1H4	B-32
1A2A14J13H4	B-10	1A3	B-12	1A3J5MP1H6	B-32
1A2A14J13H6	B-10	1A3CR1	B-36	1A3J5MP1H8	B-32
1A2A14J13MP1	B-9	1A3CR2	B-36	1A3J6	B-32
1A2A14J13MP1H3	B-9	1A3E1	B-34	1A3J6MP1H2	B-32
1A2A14MP1	B-7	1A3E1MP1H1	B-34	1A3J6MP1H4	B-32
1A2A14MP1H2	B-7	1A3E2	B-34	1A3J6MP1H6	B-32
1A2A14MP1H4	B-7	1A3E2MP1H1	B-34	1A3J6MP1H8	B-32
1A2A14MP1H6	B-7	1A3E3	B-34	1A3J7	B-32
1A2A14MP1H8	B-7	1A3E3MP1H1	B-34	1A3J7MP1	B-32
1A2A14MP1H9	B-7	1A3E4	B-34	1A3J7MP1H2	B-33
1A2A14MP2	B-7	1A3E4MP1H1	B-35	1A3J7MP1H4	B-33
1A2A14MP2H2	B-7	1A3E5	B-35	1A3J7MP1H6	B-33
1A2A14MP2H4	B-7	1A3E5MP1H1	B-35	1A3J7MP1H8	B-33
1A2A14MP2H6	B-7	1A3F1	B-34	1A3J8	B-33
1A2A14MP2H8	B-7	1A3FL1	B-33	1A3J8MP1H2	B-33
1A2A14MP2H9	B-7	1A3FL1MP1H4	B-33	1A3J8MP1H4	B-33
1A2A14MP3	B-7	1A3FL1MP1H8	B-33	1A3J8MP1H6	B-33
1A2A14MP3H2	B-7	1A3FL2	B-33	1A3J8MP1H8	B-33
1A2A14MP3H6	B-7	1A3FL2MP1H4	B-33	1A3J9	B-33
1A2A14MP3H8	B-7	1A3FL2MP1H8	B-34	1A3J9MP1	B-33
1A2A14MP3H9	B-7	1A3FL3	B-34	1A3J9MP1H2	B-33
1A2A14MP4	B-7	1A3FL3MP1H4	B-34	1A3J9MP1H4	B-33
1A2A14MP5	B-7	1A3FL3MP1H8	B-34	1A3J9MP1H8	B-33
1A2A14MP6	B-8	1A3FL4	B-34	1A3J10	B-33
1A2A14MP6H3	B-8	1A3FL4MP1H4	B-34	1A3J10MP1H2	B-33
1A2A14MP6H6	B-8	1A3FL4MP1H8	B-34	1A3J10MP1H4	B-33
1A2A14MP7	B-8	1A3J1	B-31	1A3J10MP1H6	B-33
1A2A14MP7H4	B-8	1A3J1MP1	B-31	1A3J10MP1H8	B-33
1A2A14MP7H8	B-8	1A3J1MP1H4	B-31	1A3L1	B-36
1A2A14MP7H12	B-8	1A3J1MP1H6	B-31	1A3L1MP1H2	B-36
1A2A14MP9	B-8	1A3J1MP1H8	B-31	1A3MP1	B-30
1A2A14MP11	B-8	1A3J2	B-31	1A3MP1H1	B-30
1A2A14MP11H1	B-8	1A3J2MP1H2	B-31	1A3MP1H2	B-30
1A2A14MP11H2	B-8	1A3J2MP1H4	B-31	1A3MP1H3	B-30
1A2A14MP11H3	B-8	1A3J2MP1H6	B-32	1A3MP1H4	B-30
1A2A14MP11H4	B-8	1A3J2MP1H8	B-32	1A3MP2	B-30
1A2A14MP12	B-8	1A3J3	B-32	1A3MP2H1	B-30
1A2A14MP12H1	B-8	1A3J3MP1H2	B-32	1A3MP2H2	B-30
1A2A14MP12H2	B-8	1A3J3MP1H4	B-32	1A3MP2H3	B-30
1A2A14MP12H3	B-8	1A3J3MP1H6	B-32	1A3MP2H4	B-30

**SECTION IV. INDEX-REFERENCE DESIGNATION
CROSS REFERENCE TO PAGE NUMBER**

REFERENCE DESIGNATION	PAGE NO.	REFERENCE DESIGNATION	PAGE NO.	REFERENCE DESIGNATION	PAGE NO.
1A3MP3	B-30	1A3A1C9	B-24	1A3A2CR4	B-17
1A3MP3H1	B-30	1A3A1E1	B-24	1A3A2E1	B-16
1A3MP3H2	B-30	1A3A1MP1	B-23	1A3A2MP1	B-15
1A3MP3H3	B-30	1A3A1MP1H2	B-24	1A3A2MP1H2	B-15
1A3MP3H4	B-30	1A3A1MP1H4	B-24	1A3A2MP1H4	B-15
1A3MP4	B-30	1A3A1MP1H6	B-24	1A3A2MP1H6	B-15
1A3MP4H1	B-30	1A3A1MP1H8	B-24	1A3A2MP1H8	B-15
1A3MP4H2	B-30	1A3A1P1	B-24	1A3A2P1	B-16
1A3MP4H3	B-30	1A3A1P1MP1H2	B-24	1A3A2P1MP1H2	B-16
1A3MP4H4	B-30	1A3A1P1MP1H4	B-24	1A3A2P1MP1H4	B-16
1A3MP5	B-30	1A3A1P1MP1H6	B-24	1A3A2P1MP1H6	B-16
1A3MP5H1	B-30	1A3A1P1MP1H8	B-24	1A3A2P1MP1H8	B-16
1A3MP5H2	B-30	1A3A1Q1	B-25	1A3A2Q1	B-17
1A3MP5H3	B-30	1A3A1Q2	B-25	1A3A2Q2	B-17
1A3MP5H4	B-31	1A3A1Q3	B-25	1A3A2Q3	B-17
1A3MP6	B-31	1A3A1R1	B-24	1A3A2Q4	B-17
1A3MP6H1	B-31	1A3A1R2	B-24	1A3A2Q5	B-17
1A3MP6H2	B-31	1A3A1R3	B-24	1A3A2Q6	B-17
1A3MP6H3	B-31	1A3A1R4	B-24	1A3A2R1	B-16
1A3MP6H4	B-31	1A3A1R5	B-24	1A3A2R2	B-16
1A3MP7	B-31	1A3A1R6	B-24	1A3A2R3	B-16
1A3MP7H1	B-31	1A3A1R7	B-25	1A3A2R4	B-16
1A3MP7H2	B-31	1A3A1R8	B-25	1A3A2R5	B-16
1A3MP7H3	B-31	1A3A1R9	B-25	1A3A2R6	B-16
1A3MP7H4	B-31	1A3A1R10	B-25	1A3A2R7	B-16
1A3MP8	B-31	1A3A1R11	B-25	1A3A2R8	B-16
1A3MP8H1	B-31	1A3A1R12	B-25	1A3A2R9	B-16
1A3MP8H2	B-31	1A3A1R13	B-25	1A3A2R10	B-16
1A3MP8H3	B-31	1A3A1R14	B-25	1A3A2R11	B-16
1A3MP8H4	B-31	1A3A1R15	B-25	1A3A2R12	B-16
1A3Q1	B-36	1A3A1R16	B-25	1A3A2R13	B-16
1A3R9	B-36	1A3A1R17	B-25	1A3A2R14	B-16
1A3R11	B-36	1A3A1R18	B-25	1A3A2R15	B-17
1A3R15	B-36	1A3A1R19	B-25	1A3A2R16	B-17
1A3R16	B-36	1A3A1R20	B-25	1A3A2R17	B-17
1A3T1	B-36	1A3A2	B-15	1A3A2R18	B-17
1A3T1MP1	B-36	1A3A2C1	B-15	1A3A2R19	B-17
1A3XF1	B-34	1A3A2C2	B-15	1A3A2R20	B-17
1A3XF1MP1H2	B-34	1A3A2C3	B-15	1A3A2R21	B-17
1A3XF1MP1H4	B-34	1A3A2C4	B-15	1A3A2R22	B-17
1A3XF1MP1H6	B-34	1A3A2C5	B-15	1A3A2R23	B-17
1A3A1	B-23	1A3A2C6	B-15	1A3A2R24	B-17
1A3A1C1	B-24	1A3A2C7	B-16	1A3A2RT1	B-17
1A3A1C2	B-24	1A3A2C8	B-16	1A3A3C1	B-19
1A3A1C3	B-24	1A3A2C9	B-16	1A3A3C2	B-19
1A3A1C4	B-24	1A3A2C10	B-16	1A3A3C3	B-19
1A3A1C5	B-24	1A3A2C11	B-16	1A3A3C4	B-19
1A3A1C6	B-24	1A3A2CR1	B-17	1A3A3C5	B-19
1A3A1C7	B-24	1A3A2CR2	B-17	1A3A3C6	B-19
1A3A1C8	B-24	1A3A2CR3	B-17	1A3A3C7	B-19

**SECTION IV. INDEX-REFERENCE DESIGNATION
CROSS REFERENCE TO PAGE NUMBER**

REFERENCE DESIGNATION	PAGE NO.	REFERENCE DESIGNATION	PAGE NO.	REFERENCE DESIGNATION	PAGE NO.
1A3A3C8	B-19	1A3A4Q1	B-27	1A3A5R1MP1H2	B-21
1A3A3C9	B-19	1A3A4Q2	B-27	1A3A5R1MP1H4	B-21
1A3A3C10	B-19	1A3A4Q3	B-27	1A3A5R1MP1H6	B-21
1A3A3E1	B-20	1A3A4R1	B-26	1A3A5R1MP1MP1	B-21
1A3A3MP1	B-19	1A3A4R2	B-26	1A3A5R1MP1MP3	B-21
1A3A3MP1H2	B-19	1A3A4R3	B-26	1A3A5R1MP1MP5	B-21
1A3A3MP1H4	B-19	1A3A4R4	B-26	1A3A5R1MP1MP6	B-21
1A3A3MP1H6	B-19	1A3A4R5	B-26	1A3A5R1MP1MP7	B-21
1A3A3MP1H8	B-19	1A3A4R6	B-26	1A3A5R1MP1MP8	B-21
1A3A3P1	B-19	1A3A4R7	B-26	1A3A5R1MP1MP12	B-21
1A3A3P1H8	B-19	1A3A4R8	B-26	1A3A5R2	B-22
1A3A3P1MP1H2	B-19	1A3A4R9	B-26	1A3A5R2E1	B-22
1A3A3P1MP1H4	B-19	1A3A4R10	B-26	1A3A5R2E2	B-22
1A3A3P1MP1H6	B-20	1A3A4R11	B-26	1A3A5R2MP1	B-22
1A3A3Q1	B-20	1A3A4R12	B-26	1A3A5R2MP1H2	B-22
1A3A3Q2	B-20	1A3A4R13	B-26	1A3A5R2MP1H4	B-22
1A3A3Q3	B-20	1A3A4R14	B-26	1A3A5R2MP1H6	B-22
1A3A3R1	B-20	1A3A4R15	B-27	1A3A5R2MP1MP1	B-22
1A3A3R2	B-20	1A3A4R16	B-27	1A3A5R2MP1MP3	B-22
1A3A3R3	B-20	1A3A4RT1	B-27	1A3A5R2MP1MP5	B-22
1A3A3R4	B-20	1A3A4RT2	B-27	1A3A5R2MP1MP6	B-22
1A3A3R5	B-20	1A3A4RT3	B-27	1A3A5R2MP1MP7	B-22
1A3A3R6	B-20	1A3A4T1	B-27	1A3A5R2MP1MP8	B-22
1A3A3R7	B-20	1A3A4T2	B-27	1A3A5R2MP1MP12	B-22
1A3A3R8	B-20	1A3A4T3	B-27	1A3A5R3	B-22
1A3A3R9	B-20	1A3A5	B-20	1A3A5R3E1	B-23
1A3A3R10	B-20	1A3A5C1	B-21	1A3A5R3E2	B-23
1A3A3R11	B-20	1A3A5C2	B-21	1A3A5R3MP1	B-22
1A3A3R12	B-20	1A3A5C3	B-21	1A3A5R3MP1H2	B-22
1A3A3R13	B-20	1A3A5C4	B-21	1A3A5R3MP1H4	B-22
1A3A3R14	B-20	1A3A5C5	B-21	1A3A5R3MP1H6	B-22
1A3A3R15	B-20	1A3A5CR1	B-23	1A3A5R3MP1MP1	B-22
1A3A4	B-25	1A3A5CR2	B-23	1A3A5R3MP1MP3	B-22
1A3A4C1	B-25	1A3A5CR3	B-23	1A3A5R3MP1MP5	B-22
1A3A4C2	B-25	1A3A5CR4	B-23	1A3A5R3MP1MP6	B-22
1A3A4C3	B-26	1A3A5E1	B-21	1A3A5R3MP1MP7	B-22
1A3A4C4	B-26	1A3A5MP1	B-20	1A3A5R3MP1MP8	B-23
1A3A4C6	B-26	1A3A5MP1H2	B-20	1A3A5R3MP1MP12	B-23
1A3A4C7	B-26	1A3A5MP1H4	B-20	1A3A5R4	B-23
1A3A4C8	B-26	1A3A5MP1H6	B-20	1A3A5R5	B-23
1A3A4E1	B-26	1A3A5MP1H8	B-21	1A3A5R5E1	B-23
1A3A4MP1	B-25	1A3A5P1	B-21	1A3A5R5E2	B-23
1A3A4MP1H4	B-25	1A3A5P1MP1H2	B-21	1A3A5R5MP1	B-23
1A3A4MP1H6	B-25	1A3A5P1MP1H4	B-21	1A3A5R5MP1H2	B-23
1A3A4MP1H8	B-25	1A3A5P1MP1H6	B-21	1A3A5R5MP1H4	B-23
1A3A4P1	B-26	1A3A5P1MP1H8	B-21	1A3A5R5MP1H6	B-23
1A3A4P1MP1H2	B-26	1A3A5R1	B-21	1A3A5R5MP1MP1	B-23
1A3A4P1MP1H4	B-26	1A3A5R1E1	B-21	1A3A5R5MP1MP3	B-23
1A3A4P1MP1H6	B-26	1A3A5R1E2	B-22	1A3A5R5MP1MP5	B-23
1A3A4P1MP1H8	B-26	1A3A5R1MP1	B-21	1A3A5R5MP1MP6	B-23

**SECTION IV. INDEX-REFERENCE DESIGNATION
CROSS REFERENCE TO PAGE NUMBER**

REFERENCE DESIGNATION	PAGE NO.	REFERENCE DESIGNATION	PAGE NO.	REFERENCE DESIGNATION	PAGE NO.
1A3A5R5MP1MP7	B-23	1A3A7R1	B-29	1A3A9	B-12
1A3A5R5MP1MP8	B-23	1A3A7R2	B-29	1A3A9C1	B-13
1A3A5R5MP1MP12	B-23	1A3A7R3	B-29	1A3A9C2	B-13
1A3A6	B-17	1A3A7R4	B-29	1A3A9C3	B-13
1A3A6C1	B-18	1A3A7R5	B-29	1A3A9C4	B-13
1A3A6C2	B-18	1A3A7R6	B-29	1A3A9CR1	B-13
1A3A6C3	B-18	1A3A7R7	B-29	1A3A9CR2	B-13
1A3A6C4	B-18	1A3A7R8	B-29	1A3A9CR3	B-13
1A3A6C5	B-18	1A3A7R9	B-29	1A3A9E1	B-13
1A3A6E1	B-18	1A37AR10	B-29	1A3A9P1	B-12
1A3A6MP1	B-17	1A37AR11	B-29	1A3A9MP1H2	B-12
1A3A6MP1H2	B-17	1A3A7R12	B-29	1A3A9MP1H4	B-12
1A3A6MP1H4	B-17	1A3A7R13	B-29	1A3A9MP1H6	B-12
1A3A6MP1H6	B-18	1A3A7R14	B-29	1A3A9MP1H8	B-13
1A3A6MP1H8	B-18	1A3A7R15	B-29	1A3A9P1	B-13
1A3A6P1	B-18	1A3A7T1	B-29	1A3A9P1MP1H2	B-13
1A3A6P1MP1H2	B-18	1A3A8	B-27	1A3A9P1MP1H4	B-13
1A3A6P1MP1H4	B-18	1A3A8CR1	B-28	1A3A9P1MP1H6	B-13
1A3A6P1MP1H6	B-18	1A3A8CR2	B-28	1A3A9P1MP1H8	B-13
1A3A6P1MP1H8	B-18	1A3A8CR3	B-28	1A3A9Q1	B-13
1A3A6R1	B-18	1A3A8CR4	B-28	1A3A9Q2	B-13
1A3A6R1E1	B-19	1A3A8E1	B-27	1A3A9R1	B-13
1A3A6R1E2	B-19	1A3A8MP1	B-27	1A3A9R2	B-13
1A3A6R1MP1	B-18	1A3A8MP1H2	B-27	1A3A9R3	B-13
1A3A6R1MP1H2	B-18	1A3A8MP1H4	B-27	1A3A9R4	B-13
1A3A6R1MP1H4	B-18	1A3A8MP1H6	B-27	1A3A9R5	B-13
1A3A6R1MP1H6	B-18	1A3A8MO1H8	B-27	1A3A9R6	B-13
1A3A6R1MP1MP1	B-18	1A3A8P1	B-27	1A3A9R7	B-13
1A3A6R1MP1MP3	B-18	1A3A8P1MP1H2	B-27	1A3A9R8	B-13
1A3A6R1MP1MP5	B-18	1A3A8P1MP1H4	B-27	1A3A9R9	B-13
1A3A6R1MP1MP6	B-18	1A3A8P1MP1H6	B-27	1A3A10	B-14
1A3A6R1MP1MP7	B-18	1A3A8P1MP1H8	B-27	1A3A10C1	B-14
1A3A6R1MP1MP8	B-18	1A3A8R1	B-27	1A3A10C2	B-14
1A3A6R2	B-18	1A3A8R2	B-27	1A3A10C3	B-14
1A3A6R3	B-19	1A3A8R3	B-28	1A3A10C4	B-14
1A3A6R4	B-19	1A3A8R4	B-28	1A3A10C5	B-14
1A3A7	B-28	1A3A8R5	B-28	1A3A10CR1	B-15
1A3A7C1	B-29	1A3A8R6	B-28	1A3A10CR2	B-15
1A3A7C2	B-29	1A3A8R7	B-28	1A3A10CR3	B-15
1A3A7E1	B-29	1A3A8R8	B-28	1A3A10CR4	B-15
1A3A7MP1	B-28	1A3A8R9	B-28	1A3A10E1	B-14
1A3A7MP1H2	B-28	1A3A8R10	B-28	1A3A10MP1	B-14
1A3A7MP1H4	B-28	1A3A8R11	B-28	1A3A10MP1H2	B-14
1A3A7MP1H6	B-28	1A3A8R12	B-28	1A3A10MP1H4	B-14
1A3A7MP1H8	B-29	1A3A8R14	B-28	1A3A10MP1H6	B-14
1A3A7P1	B-29	1A3A8R15	B-28	1A3A10MP1H8	B-14
1A3A7P1MP1H2	B-29	1A3A8R16	B-28	1A3A10P1	B-14
1A3A7P1MP1H4	B-29	1A3A8R17	B-28	1A3A10P1MP1H2	B-14
1A3A7P1MP1H6	B-29	1A3A8R18	B-28	1A3A10P1MP1H4	B-14
1A3A7P1MP1H8	B-29	1A3A8R19	B-28	1A3A10P1MP1H6	B-14

**SECTION IV. INDEX-REFERENCE DESIGNATION
CROSS REFERENCE TO PAGE NUMBER**

REFERENCE DESIGNATION	PAGE NO.	REFERENCE DESIGNATION	PAGE NO.	REFERENCE DESIGNATION	PAGE NO.
1A3A10P1MP1H8	B-14	1A4E2	B-42	1A4E34	B-45
1A3A10Q1	B-15	1A4E3	B-42	1A4E35	B-45
1A3A10Q2	B-15	1A4E4	B-42	1A4E36	B-45
1A3A10R1	B-14	1A4E5	B-42	1A4E37	B-45
1A3A10R2	B-14	1A4E6	B-42	1A4E38	B-46
1A3A10R3	B-14	1A4E7	B-42	1A4E39	B-46
1A3A10R4	B-14	1A4E8	B-43	1A4F2	B-40
1A3A10R5	B-14	1A4E9	B-43	1A4F3	B-40
1A3A10R6	B-14	1A4E10	B-43	1A4F4	B-40
1A3A10R7	B-14	1A4E11	B-43	1A4F5	B-40
1A3A10R8	B-14	1A4E12	B-43	1A4M1	B-41
1A3A10R9	B-15	1A4E13	B-43	1A4MP1	B-36
1A3A10R10	B-15	1A4E14	B-43		
1A3A10R11	B-15	1A4E15	B-43	1A4MP1H4	B-36
1A3A10R12	B-15	1A4E16	B-44	1A4MP1H6	B-37
1A3A10R13	B-15	1A4E16E1	B-44	1A4MP2	B-37
1A3A10R14	B-15	1A4E16MP1H1	B-44	1A4MP2H2	B-37
1A3A10R15	B-15	1A4E17	B-44	1A4MP2H4	B-37
1A3A11	B-35	1A4E17E1	B-44	1A4MP2H6	B-37
1A3A11MP1	B-35	1A4E17MP1H1	B-44	1A4P3	B-37
1A3A11MP1H4	B-35	1A4E18	B-44	1A4MP3H2	B-37
1A3A11MP1H8	B-35	1A4E18E1	B-44	1A4MP3H4	B-37
1A3A11MP1H12	B-35	1A4E18MP1H1	B-44	1A4MP3H6	B-37
1A3A11MP2	B-35	1A4E19	B-44	1A4MP4	B-37
1A3A11MP3	B-35	1A4E19E1	B-44	1A4MP4H6	B-37
1A3A11MP4	B-35	1A4E19MP1H1	B-44	1A4MP4H12	B-37
1A3A11MP8	B-35	1A4E20	B-44	1A4MP4H18	B-37
1A3A11MP9	B-35	1A4E20E1	B-44	1A4MP5	B-37
1A3A11MP10	B-35	1A4E20MP1H1	B-44	1A4MP6	B-37
1A3A11MP11	B-35	1A4E21	B-45	1A4MP6H8	B-37
1A3A11MP12	B-35	1A4E21E1	B-45	1A4MP6H12	B-37
1A3A11MP13	B-35	1A4E21MP1H1	B-45	1A4MP6H16.	B-38
1A3A11MP14	B-35	1A4E22	B-45	1A4MP6H20	B-38
1A3A11MP15	B-35	1A4E22E1	B-45	1A4MP6MP1	B-38
1A3A11MP16	B-35	1A4E22MP1H1	B-45	1A4MP6MP2	B-38
1A3A11MP17	B-35				
1A3A11MP18	B-35				
1A3A11MP19	B-35	1A4E23E1	B-45	1A4MP8	B-38
1A3A11MP20	B-35	1A4E23MP1H1	B-45	1A4MP9	B-38
1A4	B-36	1A4E24	B-45	1A4MP10	B-38
1A4AT1	B-37	1A4E24E1	B-45	1A4MP10H1	B-38
1A4AT1MP1H4	B-37	1A4E24MP1H1	B-45	1A4MP10H2	B-38
1A4AT2	B-37	1A4E25	B-45	1A4MP10H3	B-38
1A4AT2MP1H4	B-37	1A4E26	B-45	1A4MP10H4	B-38
1A4AT3	B-37	1A4E27	B-45	1A4MP11	B-38
1A4AT3MP1H4	B-37	1A4E28	B-45	1A4MP11H1	B-38
1A4AT4	B-37	1A4E29	B-45	1A4MP11H2	B-38
1A4AT4MP1H4	B-37	1A4E30	B-45	1A4MP11H3	B-38
1A4DS1	B-41	1A4E31	B-45	1A4MP11H3	B-38
1A4DS2	B-41	1A4E32	B-45	1A4MP11H4	B-38
1A4E1	B-42	1A4E33	B-45	1A4MP12H1	B-38

**SECTION IV. INDEX-REFERENCE DESIGNATION
CROSS REFERENCE TO PAGE NUMBER**

REFERENCE DESIGNATION	PAGE NO.	REFERENCE DESIGNATION	PAGE NO.	REFERENCE DESIGNATION	PAGE NO.
1A4MP12H2	B-38	1A4MP35H4	B-41	1A4S8	B-44
1A4MP12H3	B-38	1A4MP35H8	B-41	1A4S9	B-44
1A4MP12H4	B-39	1A4MP35H12	B-42	1A4T2	B-46
1A4MP13	B-39	1A4MP35H16	B-42	1A4T2MP1H4	B-46
1A4MP13H1	B-39	1A4MP36	B-42	1A4T2MP1H8	B-46
1A4MP13H2	B-39	1A4MP36MP1	B-42	1A4T2MP1H12	B-46
1A4MP13H3	B-39	1A4MP36MP1H2	B-42	1A4W1	B-38
1A4MP13H4	B-39	1A4MP36MP1H4	B-42	1A4W2	B-38
1A4MP14	B-39	1A4MP37	B-42	1A4W3	B-38
1A4MP14H1	B-39	1A4MP37MP1	B-42	1A4W3P1	B-38
1A4MP14H2	B-39	1A4MP37MP1H2	B-42	1A4XF3	B-40
1A4MP14H3	B-39	1A4MP37MP1H4	B-42	1A4XF4	B-40
1A4MP14H4	B-39	1A4MP38	B-42	1A4XF5	B-40
1A4MP15	B-39	1A4MP38MP1	B-42	1A4A1	B-40
1A4MP15H1	B-39	1A4MP38MP1H2	B-42	1A42AC1	B-40
1A4MP15H2	B-39	1A4MP38MP1H4	B-42	1A4A1CR1	B-40
1A4MP15H3	B-39	1A4MP39	B-42	1A4A1CR2	B-40
1A4MP15H4	B-39	1A4MP39MP1	B-42	1A4A1DS1MP1H2	B-40
1A4MP16	B-39	1A4MP39MP1H2	B-42	1A4A1DS1MP1H4	B-40
1A4MP16H1	B-39	1A4MP39MP1H4	B-42	1A4A1DS1MP1H6	B-40
1A4MP16H2	B-39	1A4MP40	B-43	1A4A1MP1	B-40
1A4MP16H3	B-39	1A4MP41	B-43	1A4A1MP1H2	B-40
1A4MP16H4	B-39	1A4R1	B-43	1A4A1MP1H4	B-40
1A4MP17	B-39	1A4R12	B-46	1A4A1R1	B-40
1A4MP18	B-39	1A4R13	B-46		
1A4MP19	B-39	1A4R14	B-46		
1A4MP20	B-39	1A4R17	B-46		
1A4MP21	B-40	1A4R18	B-46		
1A4MP21H2	B-40	1A4S1	B-44		
1A4MP21H4	B-40	1A4S2	B-44		
1A4MP21H6	B-40	1A4S3	B-44		
1A4MP21H8	B-40	1A4S4	B-44		
1A4MP22	B-41	1A4S5	B-43		
1A4MP22H2	B-41	1A4S5MP1	B-43		
1A4MP22H4	B-41	1A4S5MP1H2	B-43		
1A4MP23	B-41	1A4S5MP1H4	B-43		
1A4MP23H2	B-41	1A4S5MP1H6	B-43		
1A4MP23H4	B-41	1A4S5MP1H8	B-43		
1A4MP24	B-41	1A4S6	B-43		
1A4MP25	B-41	1A4S6MP1	B-43		
1A4MP26	B-41	1A4S6MP2	B-43		
1A4MP27	B-41	1A4S6MP2H2	B-43		
1A4MP28	B-41	1A4S6MP2H4	B-43		
1A4MP29	B-41	1A4S6MP2H6	B-43		
1A4MP30	B-41	1A4S7	B-43		
1A4MP31	B-41	1A4S7MP1	B-43		
1A4MP32	B-41	1A4S7MP1H2	B-44		
1A4MP33	B-41	1A4S7MP1H4	B-44		
1A4MP34	B-41	1A4S7MP1H6	B-44		
1A4MP35	B-41	1A4S7MP1H8	B-44		

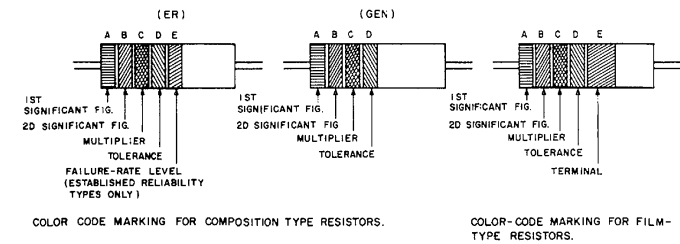

TABLE 1
COLOR CODE FOR COMPOSITION TYPE AND FILM TYPE RESISTORS.

BAND A		BAND B		BAND C		BAND D		BAND E	
COLOR	FIRST SIGNIFICANT FIGURE	COLOR	SECOND SIGNIFICANT FIGURE	COLOR	MULTIPLIER	COLOR	RESISTANCE TOLERANCE (PERCENT)	COLOR	FAILURE RATE LEVEL
BLACK	0	BLACK	0	BLACK	1			BROWN	M
BROWN	1	BROWN	1	BROWN	10			RED	P
RED	2	RED	2	RED	100			ORANGE	R
ORANGE	3	ORANGE	3	ORANGE	1,000			YELLOW	S
YELLOW	4	YELLOW	4	YELLOW	10,000	SILVER	±10 (COMP. TYPE ONLY)	WHITE	
GREEN	5	GREEN	5	GREEN	100,000	GOLD	±5		
BLUE	6	BLUE	6	BLUE	1,000,000	RED	±2 (NOT APPLICABLE TO ESTABLISHED RELIABILITY)		
PURPLE (VIOLET)	7	PURPLE (VIOLET)	7						SOLD-ERABLE
GRAY	8	GRAY	8	SILVER	1.01				
WHITE	9	WHITE	9	GOLD	0.1				

BAND A — THE FIRST SIGNIFICANT FIGURE OF THE RESISTANCE VALUE (BANDS A THRU D SHALL BE OF EQUAL WIDTH.)

BAND B — THE SECOND SIGNIFICANT FIGURE OF THE RESISTANCE VALUE.

BAND C — THE MULTIPLIER (THE MULTIPLIER IS THE FACTOR BY WHICH THE TWO SIGNIFICANT FIGURES ARE MULTIPLIED TO YIELD THE NOMINAL RESISTANCE VALUE.)

BAND D — THE RESISTANCE TOLERANCE.

BAND E — WHEN USED ON COMPOSITION RESISTORS, BAND E INDICATES ESTABLISHED RELIABILITY FAILURE-RATE LEVEL. ON FILM RESISTORS, THIS BAND SHALL BE APPROXIMATELY 1-1/2 TIMES THE WIDTH OF OTHER BANDS, AND INDICATES TYPE OF TERMINAL.

RESISTANCES IDENTIFIED BY NUMBERS AND LETTERS (THESE ARE NOT COLOR CODED)

SOME RESISTORS ARE IDENTIFIED BY THREE OR FOUR DIGIT ALPHA NUMERIC DESIGNATORS. THE LETTER R IS USED IN PLACE OF A DECIMAL POINT WHEN FRACTIONAL VALUES OF AN OHM ARE EXPRESSED. FOR EXAMPLE:

2R7 = 2.7 OHMS 10R0 = 10.0 OHMS

FOR WIRE-WOUND-TYPE RESISTORS COLOR CODING IS NOT USED, IDENTIFICATION MARKING IS SPECIFIED IN EACH OF THE APPLICABLE SPECIFICATIONS.

EXAMPLES OF COLOR CODING

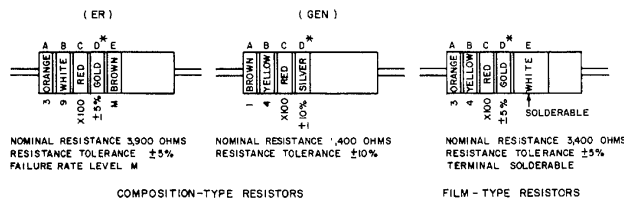

* IF BAND D IS OMITTED, THE RESISTOR TOLERANCE IS ±20% AND THE RESISTOR IS NOT MIL-STD.

A. COLOR CODE MARKING FOR MILITARY STANDARD RESISTORS.

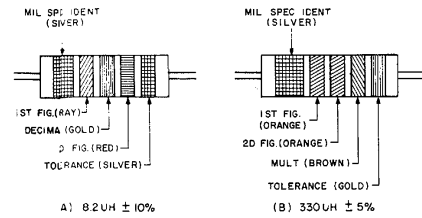

COLOR CODING FOR TUBULAR ENCAPSULATED R.F. CHOKES. AT A, AN EXAMPLE OF THE CODING FOR AN 8.2UH CHOKE IS GIVEN. AT B, THE COLOR BANDS FOR A 330 UH INDUCTOR ARE ILLUSTRATED.

TABLE 2
COLOR CODING FOR TUBULAR ENCAPSULATED R.F. CHOKES.

COLOR	SIGNIFICANT FIGURE	MULTIPLIER	INDUCTANCE TOLERANCE (PERCENT)
BLACK	0	1	
BROWN	1	10	1
RED	2	100	2
ORANGE	3	1,000	3
YELLOW	4		
GREEN	5		
BLUE	6		
VIOLET	7		
GRAY	8		
WHITE	9		
NONE			20
SILVER			10
SOLD	DECIMAL POINT		5

MULTIPLIER IS THE FACTOR BY WHICH THE TWO COLOR FIGURES ARE MULTIPLIED TO OBTAIN THE INDUCTANCE VALUE OF THE CHOKE COIL.

COLOR CODE MARKING FOR MILITARY STANDARD INDUCTORS.

CAPACITORS, FIXED, VARIOUS-DIELECTRICS, STYLES CM, CN, CY, AND CB.

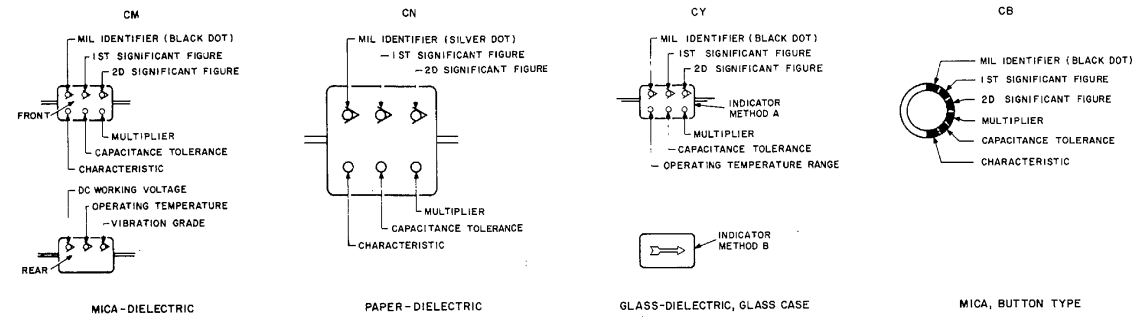

TABLE 3 — FOR USE WITH STYLES CM, CN, CY AND CB.

COLOR	MIL ID	1ST SIG FIG	2D SIG FIG	MULTIPLIER	CAPACITANCE TOLERANCE				CHARACTERISTIC	DC WORKING VOLTAGE
					CM	CN	CY	CB		
BLACK	CM, CY, CB	0	0	1			±20%	±20%	A	
BROWN		1	1	10					B	E
RED		2	2	100	±2%		±2%	±2%	C	D
ORANGE		3	3	1,000	±30%				D	300
YELLOW		4	4	10,000					E	
GREEN		5	5		±5%				F	300
BLUE		6	6							
PURPLE (VIOLET)		7	7							
GRAY		8	8							
WHITE		9	9							
GOLD				0.1			±5%	±5%		
SILVER	CN				±10%	±10%	±10%	±10%		

TABLE 4 — TEMPERATURE COMPENSATING, STYLE CC.

COLOR	TEMPERATURE COEFFICIENT*	1ST SIG FIG	2D SIG FIG	MULTIPLIER*	CAPACITANCE TOLERANCE		MIL ID
					CAPACITANCES OVER 10 UUF	CAPACITANCES 10 UUF OR LESS	
BLACK	0	0	0	1		±2.0 UUF	CC
BROWN	-30	1	1	10	±1%		
RED	-80	2	2	100	±2%	±0.25 UUF	
ORANGE	-150	3	3	1,000			
YELLOW	-220	4	4				
GREEN	-330	5	5		±5%	±0.5 UUF	
BLUE	-470	6	6				
PURPLE (VIOLET)	-750	7	7				
GRAY		8	8	0.01			
WHITE		9	9	0.1	±10%		
GOLD	+100					±1.0 UUF	
SILVER							

1. THE MULTIPLIER IS THE NUMBER BY WHICH THE TWO SIGNIFICANT (SIG) FIGURES ARE MULTIPLIED TO OBTAIN THE CAPACITANCE IN UUF.
2. LETTERS INDICATE THE CHARACTERISTICS DESIGNATED IN APPLICABLE SPECIFICATIONS: M MIL-C-250, MIL-C-112728, AND MIL-C-10950C RESPECTIVELY.
3. LETTERS INDICATE THE TEMPERATURE RANGE AND VOLTAGE-TEMPERATURE LIMITS DES MIL-C-110150.
4. TEMPERATURE COEFFICIENT IN PARTS PER MILLION PER DEGREE CENTIGRADE.

C. CC IR CODE MARKING FOR MILITARY STANDARD CAPACITORS.

Figure 6-7. Color code marking for MIL STD resistors, inductors, and capacitors.

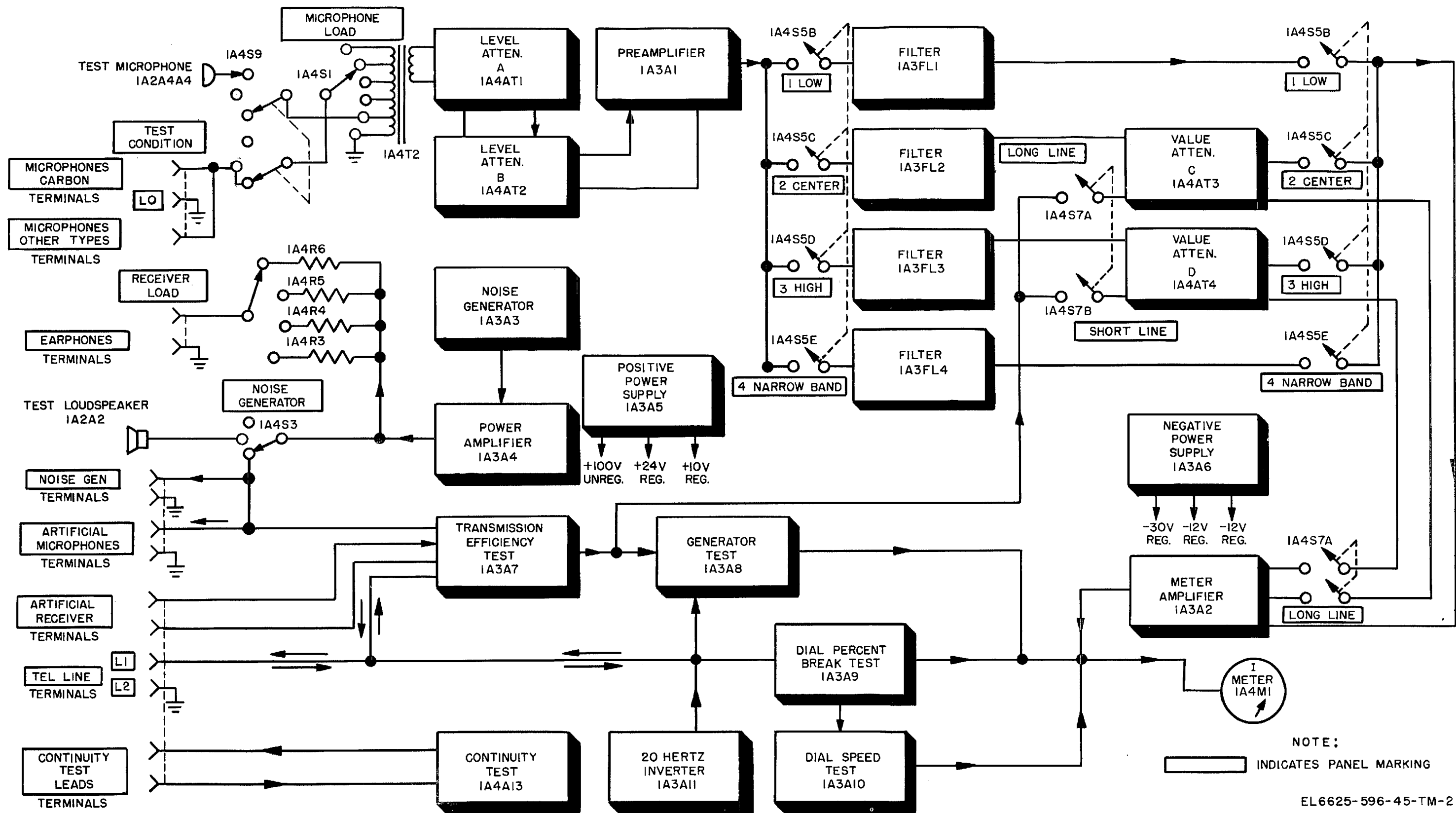

Figure 6-8. Telephone Test Set TS-716/U, simplified block diagram.

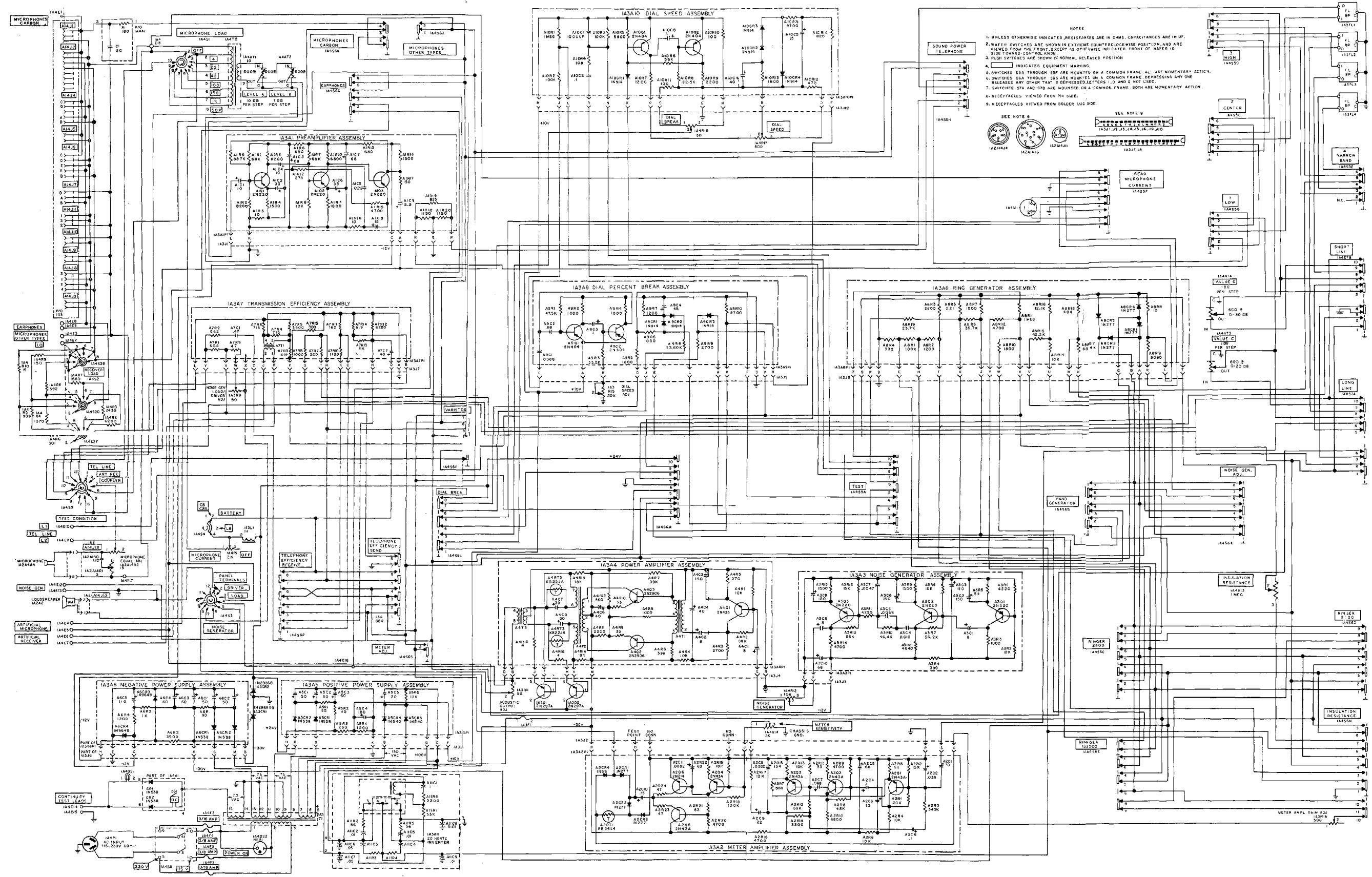

Figure 6-10. Telephone test Set TS-716/U. complete schematic diagram.

By Order of the Secretary of the Army:

W. C. WESTMORELAND,
General, United States Army,
Chief of Staff.

Official:

VERNE L. BOWERS,
Major General, United States Army,
The Adjutant General.

Distribution:

Active Army:

USASA (2)
 CNGB (1)
 ACSC-E (2)
 Dir of Trans (1)
 CofEngrs (1)
 TSG (1)
 CofSptS (1)
 USAARENBD (2)
 USAMB (10)
 USACDC (2)
 USACDC Agcy (1)
 USAMC (1)
 CONARC (5)
 ARADCOM (2)
 ARADCOM Rgn (2)
 USAAESWBD (2)
 OS Maj Comd (4)
 USARJ (3)
 USARYIS (3)
 USARHAW (3)
 LOGCOMD (5)
 USAMICOM (4)
 USATECOM (2)
 USASTRATCOM (4)
 USAESC (70)
 MDW (1)
 Armies (2)
 Corps (2)
 1st Cav Div (3)
 Svc Colleges (2)
 USASESS (10)
 USAADS (2)
 USAFAS (2)
 USAARMS (2)
 USAIS (2)
 USAES (2)
 USAINTS (3)
 WRAMC (1)
 USACDCEC (10)
 Edgewood Arsenal (3)

Instl (2) except
 Ft Gordon (10)
 Ft Huachuca (10)
 WSMR (3)
 Ft Carson (19)
 Army Dep (2) except
 LBAD (14)
 SAAD (30)
 TOAD (14)
 LEAD (7)
 NAAD (5)
 SVAD (5)
 ATAD (10)
 ANAD (5)
 Gen Dep (2)
 Sig See Gen Dep (5)
 Sig Dep (10)
 SigFLDMS (2)
 ATS (1)
 USAERDAA (2)
 USAERDAW (5)
 USACRREL (2)
 MAAG (1)
 USARMIS (1)
 Units org under fol TOE:
 (2 cys each)
 11-15
 11-16
 11-85
 11-95
 11-96
 11-117
 11-158
 11-225
 11-302
 11-500 (AA-AC)
 29-134
 29-136
 29-500

NG: None

USAR: None

For explanation of abbreviations used, see AR 310-50.

PIN: 020886-000